

| | | | | | | | |
|-----|------|-----------|-----|--------------------------|-----------|-----|------|
| LOC | DIST | REVISIONS | | | | | |
| GP | 00 | P | LTR | DESCRIPTION | DATE | DWN | APVD |
| | | | G1 | REVISE PER ECO-06-020811 | 17/OCT/06 | ZR | CR |

- 1 ZINC PLATED PER ASTM B633, TYPE II, CLASS SCI, YELLOW CHROMATE.
- 2 ZINC PLATED PER ASTM B633, TYPE III, CLASS SCI, CLEAR CHROMATE.
- 3. PARTS PACKAGED UNASSEMBLED.
- 4 PARTS PACKAGED AS A UNIT KIT.
- 5 PART INDIVIDUALLY BULK PACKED & SHIPPED AS A UNIT PACKAGE.
- 6 STAINLESS STEEL PER ASTM A666.

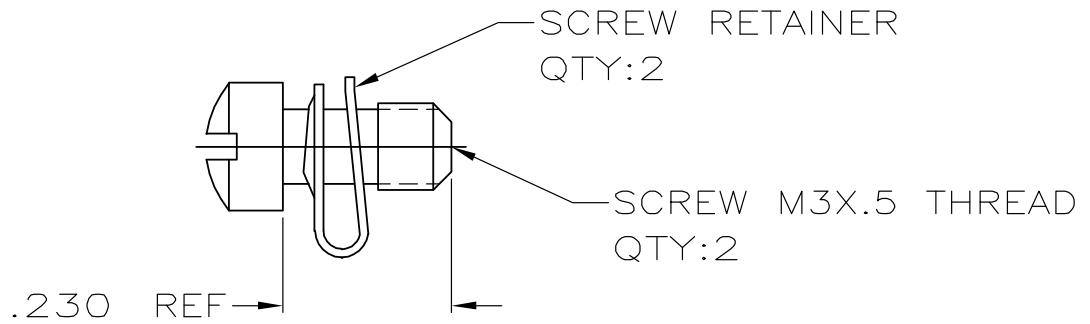

| | | | |
|----------|-----------|--------------|-------------|
| OBSOLETE | 5 | 2 | 207871-4 |
| OBSOLETE | 4 | 2 | 207871-3 |
| OBSOLETE | 5 | 1 | 207871-2 |
| OBSOLETE | 4 | 1 | 207871-1 |
| | PACKAGING | SCREW FINISH | PART NUMBER |

THIS DRAWING IS UNPUBLISHED. BY AMP INCORPORATED. ALL RIGHTS RESERVED. © COPYRIGHT 19

| | | | | | | |
|--|--------------------|---------|---|-----------------------------|------------|-------------------|
| DIMENSIONS: mm | DWN J. GALLUCCI | 4-23-90 | MATERIAL | SCREWS: STEEL RETAINERS: | FINISH | SCREWS: SEE TABLE |
| | CHK W.G. LENKER | 8-15-90 | AMP Incorporated Harrisburg, PA 17105-3608 | | | |
| TOLERANCES UNLESS OTHERWISE SPECIFIED: | APVD J. ASSINI | 7-10-90 | | | | |
| 0 PLC ±- | PRODUCT SPEC | - | SIZE | CAGE CODE | DRAWING NO | |
| 1 PLC ±- | APPLICATION SPEC | - | A4 | 00779 | C-207871 | |
| 2 PLC ±- | WEIGHT | - | CUSTOMER DRAWING | | | |
| 3 PLC ±- | | | SCALE | 4:1 | SHEET | 1 OF 1 |
| 4 PLC ±- | | | | | | REV G1 |
| ANGLES ±- | | | | | | |