

4

3

2

1



THIS DRAWING IS UNPUBLISHED. RELEASED FOR PUBLICATION  
 © COPYRIGHT 2005 BY TYCO ELECTRONICS CORPORATION. ALL RIGHTS RESERVED.

LOC	DIST	REVISIONS				
P	LTR	DESCRIPTION	DATE	DWN	APVD	
GP	00	H	REVISED PER ECO-06-025935	13/FEB/07	ZMR WLM	

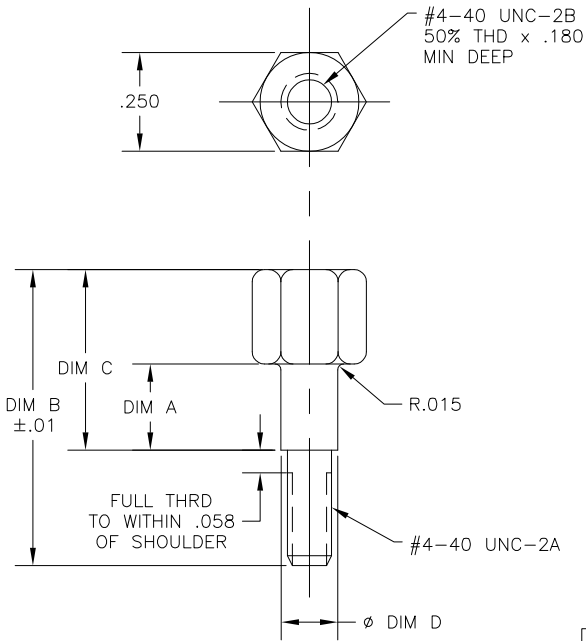
 MATERIAL: STEEL, ZINC PLATE WITH YELLOW CHROMATE.



OBSOLETE	.138-.144	.347	.64	.108	229995-2
	.138-.144	.457	.75	.218	229995-1
	Ø DIM D	DIM C	DIM B	DIM A	PART NO.

THIS DRAWING IS A CONTROLLED DOCUMENT.		DWN Z. REAM 13/FEB/07	 Tyco Electronics Corporation Harrisburg, PA 17105-3608																		
DIMENSIONS: INCHES		CHK W. MILLIMES 13/FEB/07																			
TOLERANCES UNLESS OTHERWISE SPECIFIED:		APVD B. WERTZ 13/FEB/07	NAME STAND-OFF, SUTD, MTG																		
<table border="1"> <tr><td>0</td><td>PLC</td><td>± -</td></tr> <tr><td>1</td><td>PLC</td><td>± -</td></tr> <tr><td>2</td><td>PLC</td><td>± -</td></tr> <tr><td>3</td><td>PLC</td><td>± .005</td></tr> <tr><td>4</td><td>PLC</td><td>± -</td></tr> <tr><td colspan="2">ANGLES</td><td>± -</td></tr> </table>		0	PLC	± -	1	PLC	± -	2	PLC	± -	3	PLC	± .005	4	PLC	± -	ANGLES		± -	PRODUCT SPEC APPLICATION SPEC	
0	PLC	± -																			
1	PLC	± -																			
2	PLC	± -																			
3	PLC	± .005																			
4	PLC	± -																			
ANGLES		± -																			
MATERIAL 	FINISH 	SIZE A3	CAGE CODE 00779	DRAWING NO C-229995																	
CUSTOMER DRAWING		WEIGHT -	RESTRICTED TO -	SCALE 4:1																	
		SHEET 1 OF 1		REV H																	