

LOC GP 00
 DIST 00

REVISIONS					
ZONE	LTR	DESCRIPTION	DATE	APPD	
B		REVISED & REDRAWN PER ECN-2262	-	-	
C		REVISED ECN-2364	8-1-88	L5 RW	
D		RLSE 1-1 PER NPR 3095, WAS 90-5898-17	09/04/90	-	
E		RLSE 1-3 PER NPR 3342, WAS 91-5898-1-2	2-13-91	BT	
F		REVISED PER ECN BD5212	06/26/91	-	
G		ADDED 1-6 PER NPR 3626, WAS 91-5898-18	07/12/91	-	
H		OBS -11 PER EC 001D-0251-00	23 JAN 01	DK	
J		REV PER EC 00E0-0002-01	09 JAN 02	JR	

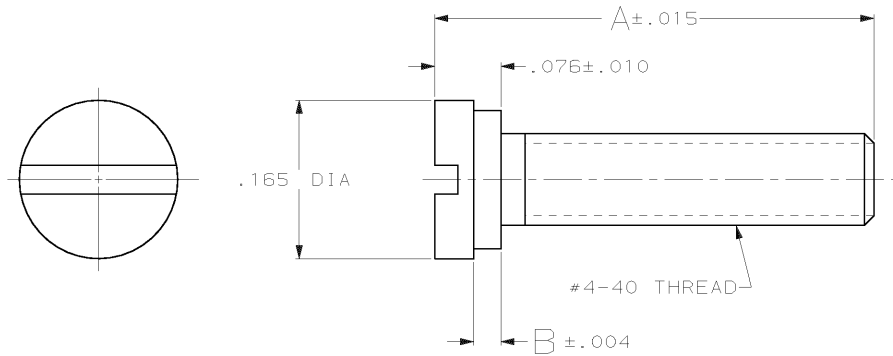

- ① ZINC PLATED PER ASTM B633, TYPE II, CLASS SC1, YELLOW CHROMATE.
- ② ZINC PLATED PER ASTM B633, TYPE II, CLASS SC1, CLEAR CHROMATE.
- ③ OBSOLETE.

①	.042	.415	1-206943-6
②	.041	.305	1-206943-3
②	.056	.290	③ 1-206943-1
①	.030	.450	206943-7
①	.030	.290	206943-5
③	.030	.415	206943-3
①	.030	.415	206943-2
FINISH		B A	PART NO

DO NOT SCALE PRINT. UNLESS SPECIFIED DIMENSIONS IN INCHES TOLERANCES ON: 2. PLC DEC ± 3. PLC DEC ± .005 ANGLES ± -	DR	E-B-BB	AMP INCORPORATED Harrisburg, Pa. 17105
	CHK	E-15-BB	
	APPD	E-16-BB	
	APPD	E-17-BB	
MATERIAL	PRODUCT SPEC	SLIDELATCH SCREW, #4-40, AMPLIMITE™	
COLD ROLLED STEEL PER ASTM A108	-	SIZE	FSCN NO
FINISH	APPLICATION SPEC	B	00779
SEE TABLE	WEIGHT	SCALE	DRAWING NO
-	-	10:1	206943
		SHEET	1 OF 1