

DRAWING MADE IN THIRD ANGLE PROJECTION
 THIS DRAWING IS UNPUBLISHED. RELEASED FOR PUBLICATION .19
 © COPYRIGHT 19 BY AMP INCORPORATED. ALL INTERNATIONAL RIGHTS RESERVED.

| LOC | DIST | P | F | ZONE | LTR | DESCRIPTION | DATE | APPD |
|-----|------|---|---|------|-----|--------------------------------|-----------|------|
| GP | 00 | | | | | | | |
| | | | | | E | REVISED & REDRAWN PER ECN-2364 | 8-16-88 | JRS |
| | | | | | F | REVISED ECN-BD3390 | 12-7-89 | JW |
| | | | | | G | REV PER ECN BD4844 | 04/05/91 | BT |
| | | | | | H | OB5 -8 PER ECN BD6177 | 06/16/92 | TS |
| | | | | | J | REV PER ECN BD6381 | 07/10/92 | TS |
| | | | | | J1 | ADDED -9 PER NPR 4907 | 08/18/93 | SB |
| | | | | | K | OB5 -9 PER EC 0020-523-96 | 13 AUG 96 | JS |
| | | | | | L | REV PER EC QUE0-0002-01 | 10 JAN 92 | JR |

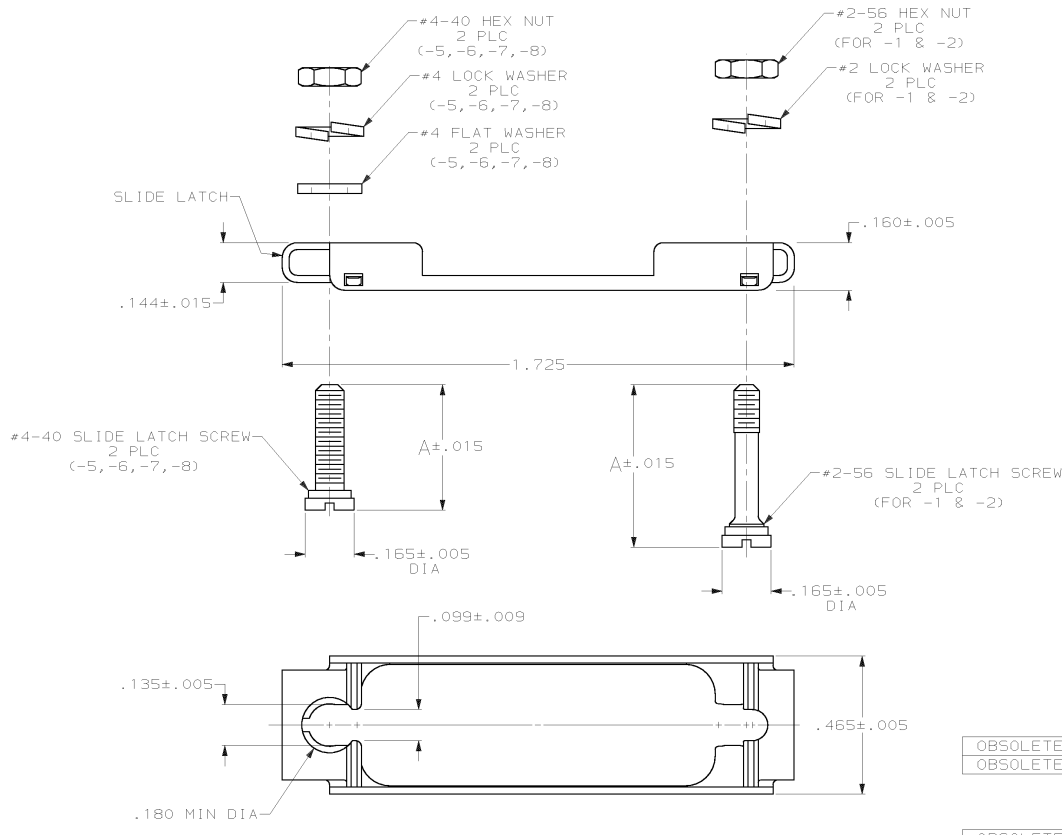

| | | | | | | |
|------------------|------|---|-------|---|---|----------|
| OBSELETE | .415 | △ | #4-40 | △ | △ | 745583-9 |
| OBSELETE | .450 | △ | #4-40 | △ | △ | 745583-8 |
| | .450 | △ | #4-40 | △ | △ | 745583-7 |
| | .415 | △ | #4-40 | △ | △ | 745583-6 |
| | .415 | △ | #4-40 | △ | △ | 745583-5 |
| OBSELETE | - | △ | #2-56 | △ | - | 745583-4 |
| SUPERSEDED BY -1 | - | △ | #2-56 | △ | - | 745583-3 |
| OBSELETE | .547 | △ | #2-56 | △ | △ | 745583-2 |
| | .547 | △ | #2-56 | △ | △ | 745583-1 |

- PARTS PACKAGED UNASSEMBLED.
- PARTS PACKAGED AS A UNIT KIT.
- PARTS INDIVIDUALLY BULK PACKAGED AND SHIPPED AS A UNIT PACKAGE.
- ZINC PLATED PER ASTM B633, TYPE III, CLASS SC1, CLEAR CHROMATE.
- ZINC PLATED PER ASTM B633, TYPE II, CLASS SC1, YELLOW CHROMATE.
- THIS KIT CAN BE USED WITH TWO-PIECE STRAIGHT/90° EXIT CABLE CLAMPS, RFI/EMI CABLE CLAMPS OR UNIVERSAL CABLE CLAMPS.
- THIS KIT CAN BE USED WITH ONE-PIECE STRAIGHT/45° EXIT CABLE CLAMPS, ONE-PIECE STRAIGHT/90° EXIT CABLE CLAMPS OR ON CONNECTORS WITHOUT CABLE CLAMPS.
- PARTS SMALL PACK PACKAGED.

| | | | | |
|---|---|---|--|----------------------|
| DO NOT SCALE PRINT. UNLESS SPECIFIED DIMENSIONS IN INCHES TOLERANCES ON : 2 PLC DEC ± - 3 PLC DEC ± .010 ANGLES ± - | DR 8-12-88 L.SIPE | AMP INCORPORATED Hanfburg, Pa. 17109 | NAME | |
| MATERIAL SLIDE LATCH: STAINLESS STEEL HARDWARE: STEEL PER ASTM A108 | CHK 8-12-88 W.LENKER APPD 8-15-88 R.WHYNE APPD 8-16-88 J.SHOWERS | | KIT, SLIDE LATCH, SIZE 2, 15 POSITION, AMPLIMITE® | |
| FINISH HARDWARE: SEE TABLE | PRODUCT SPEC - | SIZE C | FSCM NO 00779 | DRAWING NO 745583 |
| | APPLICATION SPEC - | SCALE 4:1 | | SHEET 1 OF 1 |
| | WEIGHT - | | | |