

© COPYRIGHT 1971 BY AMP INCORPORATED, HARRISBURG, PA.
 ALL INTERNATIONAL RIGHTS RESERVED. AMP INCORPORATED PRODUCTS
 COVERED BY U. S. AND FOREIGN PATENTS AND/OR PATENTS PENDING.

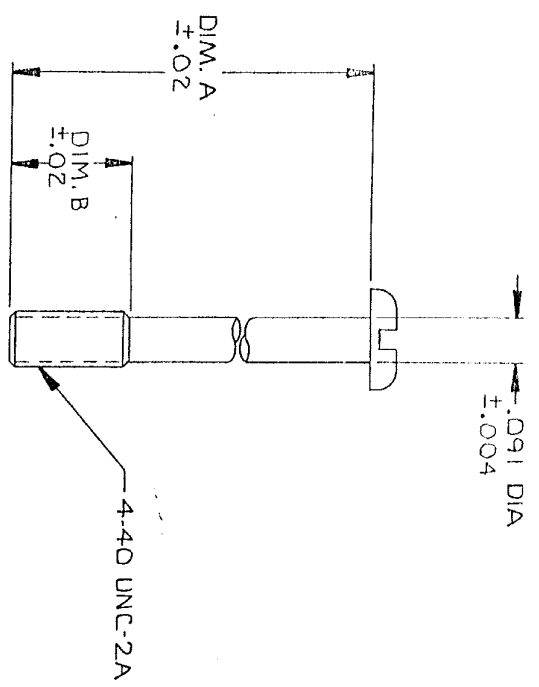

△ MATERIAL: ZINC PLATED STEEL.

REVISIONS		DATE	APPROVED
1	LOC AA	11/20	
2			
3			
4			

DESCRIPTION: OBS.-5; ECN AA-4007

DATE: 7887

APPROVED: *KS*

SCALE: 50%

DIM. B	DIM. A	PART NO
.20	1.00	-4
.13	1.75	-3
.25	.62	-2
.25	.75	229911-1

UNLESS OTHERWISE SPECIFIED DIMENSIONS ARE IN INCHES. DIMENSIONS IN DECIMALS ± ANGLES

CONTRACT NO: DR *M/D Build* 12-3-79

CHK: *Keibach* 12/3/79

APPRO: *Miller* 12/14/79

APPR: *Miller* 12/14/79

DESIGN APPD: *Miller* 12/14/79

OTHER APPD:

FINISH: △

NAME: **AMP** AMP INCORPORATED Harrisburg, Pa.

SIZE: **B** CODE IDENT NO: 00779 DRAWING NO: 229911

SCALE: 4/1 SHEET 1 OF 1

DESCRIPTION: SCREW, PAN HEAD CAPTIVE

CUSTOMER DRAWING