

1 mm Pitch Double Rows Low Profile Board-to-Cable Connectors

DF20 series

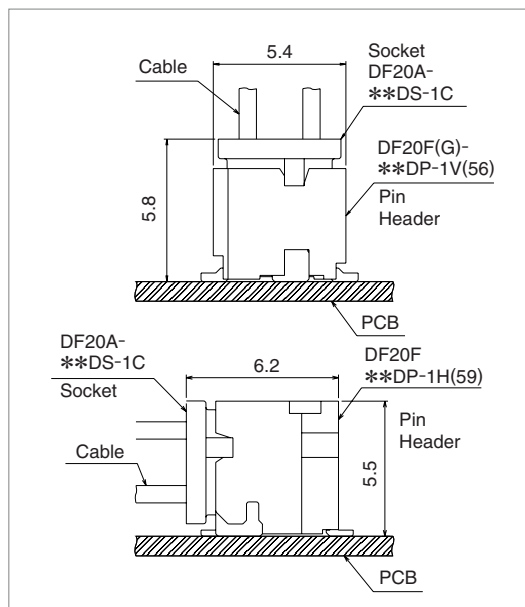

■ Features

1. Contact Pitch

1 mm contact pitch allows reliable solder and cable termination.

2. Reliable electrical connection wipe

Effective electrical connection is assured with a 1mm wipe of mating contacts.

3. Narrower external width and length

Redesigned metal fittings decreased the overall length of the board-mount receptacle and permit end-to-end mounting of several connectors.

4. Automatic equipment board placement

Straight type pin headers are supplied with a 5.4 mm X 4.6mm flat platform to allow vacuum pick-up and placement on the board.

5. Product variations

- (1) Available with 10, 20, 30, 40, and 50 contacts.
- (2) Pin headers are available in two types: with or without board positioning bosses.
- (3) Depending on specific application pin headers can be ordered in straight or right angle types.

Narrower external width and length

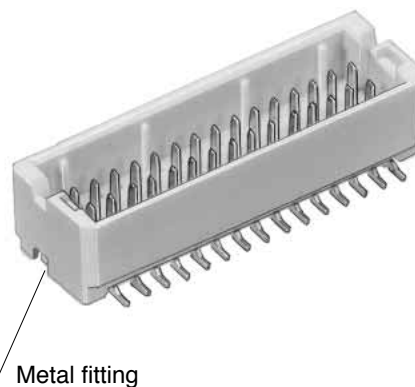

■ Applications

Notebook PC, small office automation equipment, small consumer devices, portable devices.

Any application requiring low profile reliable board-to-cable connection with a AWG #28, AWG#30, AWG#32 conductors.

1mm Pitch, Double Rows

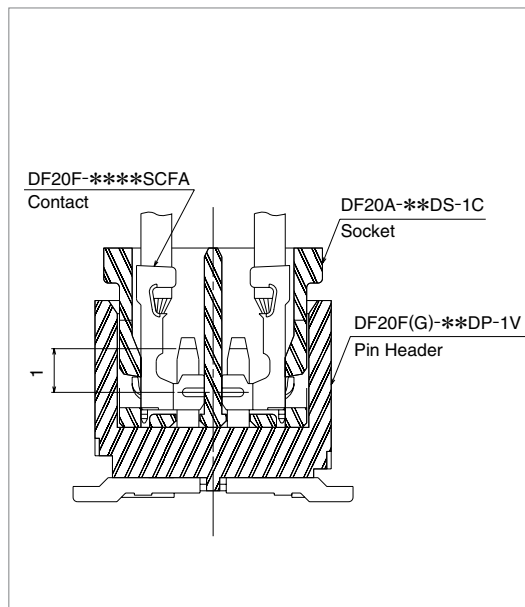

Product Specifications

Rating	Rated current	AWG#28 : 1A AWG#30 : 0.9A AWG#32 : 0.7A	Operating temperature range	-35°C to 85°C (Note 1,2)	Storage temperature range	-10°C to 60°C (Note 2)
	Rated voltage	100V AC	Operating humidity range	40% to 80%	Storage humidity range	40% to 70%

Item	Specifications	Conditions
1. Insulation resistance	500MΩ min.	Measured at 100V DC
2. Withstanding voltage	No flashover or insulation breakdown	Conduction of 300V AC applied for 1 minute
3. Contact resistance	30MΩ max.	Measure at 100mA.
4. Insertion-Extraction force (per contact)	0.2 N Min., 2 N Max.	Measured with a steel pin of 0.2 ±0.005 thickness
5. Vibration	No electrical discontinuity of 1μs min.	Frequency of 10 to 55 Hz, single amplitude of 0.75 mm, in 3 directions for 2hours
6. Humidity	Contact resistance of 30mΩ max., insulation resistance of 100MΩ min.	Temperature of 40±2°C, humidity of 90% to 95%, left standing for 96 hours
7. Temperature cycle	Contact resistance of 30mΩ max., insulation resistance of 500MΩ min.	(-55°C:30min → 5°C to 35°C: 2 to 3min → 85°C:30min → 5°C to 35°C:2 to 3min) for 5 cycles
8. Mechanical operation	Contact resistance of 30mΩ max.	50 cycles
9. Resistance to Soldering heat	No deformation of the insulator parts that will affect performance	Reflow: At the recommended temperature profile, manual solder: Soldering iron temperature of 300°C for 3 seconds

Note1: Includes temperature rise caused by current flow.

Note2: The term "storage" refers to products stored for long periods of time prior to mounting and use.

Operating temperature range and Humidity range covers non-conducting conditions of installed connectors in storage, shipment or transportation.

Note3: Information contained in this catalog represents general requirements for this Series. Contact us for the drawings and specifications for a specific part number shown.

Materials

Item	Part	Material	Finish	Remarks
Socket	Insulator	Polyamide	Color : Beige	UL94V-0
Socket contact	Contact	Phosphor bronze	Gold plating	—
Pin header	Insulator	Polyamide	Color : Beige	UL94V-0
	Contact	Phosphor bronze	Gold plating	—
	Metal Fitting	Brass	V type: Solder plating H type: Tin-Copper plating (Pb free)	

Ordering Information

Connectors

DF20 # - * DS - 1 C

① ② ③ ④ ⑤ ⑥

① Series name : DF20	④ Connector type DS: Double-row socket DP: Double-row pin header
② Boss Type ■ Pin header F: Without boss G: With boss ■ Crimp socket: A	⑤ Contact pitch: 1 mm
③ Number of contacts: 10, 20, 30, 40, 50	⑥ Type of housing, header C: Crimp housing V: Straight SMT header H: Right angle SMT header

Contacts

DF20 F - 2830 SCF A (* *)

① ② ③ ④ ⑤

① F	③ Contact & packaging type SCF: Socket contact reel	⑤ Packaging Specifications Blank: 1 reel = 10,000 pieces 41: 1 reel = 20,000 pieces
② Applicable wire size 2830: AWG #28 to 30 3032: AWG #30 to 32	④ Plating type A: Gold plating	

DF20 Series 1 mm Pitch Double Rows Low Profile Board-to-Cable Connectors

Double Row Socket

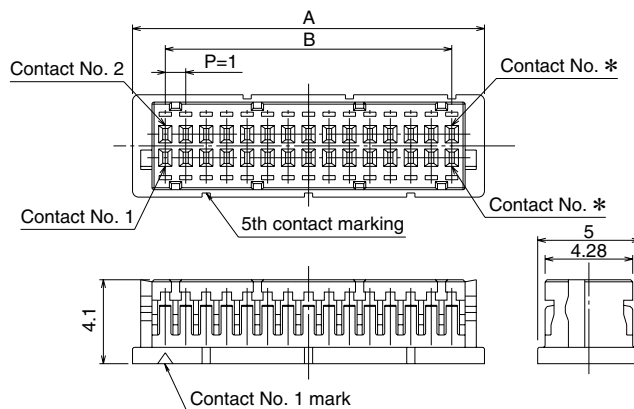

Part Number	CL No.	Number of Contacts	A	B	RoHS	Unit: mm [Specifications number]-*, (**) (59): Gold plating, embossed tape packaging
DF20A-10DS-1C	686-0020-3	10	7.2	4.0	YES	
DF20A-20DS-1C	686-0021-6	20	12.2	9.0		
DF20A-30DS-1C	686-0022-9	30	17.2	14.0		
DF20A-40DS-1C	686-0023-1	40	22.2	19.0		
DF20A-50DS-1C	686-0024-4	50	27.2	24.0		

Note: Sales quantities are by the package unit (containing 100 pieces). Please order by package unit.

Socket Crimp Contacts

Product No.	CL No.	Type of contacts	Quantity	Plating type	RoHS
DF20F-2830SCFA(**)	686-0042-6-**-	Reel contacts	See specifications number column	Gold plating	YES
DF20F-3032SCFA(**)	686-0043-9-**-				
DF20F-36SCFA(**)	686-0051-7-**-				

[Specifications number] -*, (**)
 (04): 10,000 pieces / reel
 (44): 20,000 pieces / reel

●Applicable Wire (Tin plated solid soft conductor)

Applicable Wire Size (Stranded wire conductor)	Jacket diameter
AWG #28 (7/0.127 mm)	0.5mm to 0.6 mm
AWG #30 (7/0.1 mm)	
AWG #32 (7/0.08 mm)	

- Recommended wire UL1571
- Strip length 1.2 to 1.9 mm

Note: When using other than the recommended wire, contact your nearest Hirose representative.

●Applicable Crimping Tools

Type	CL No.	Product No.
Applicator	901-4572-6	AP105-DF20-2830S
Press	901-0005-4	CM-105

Note 1: Hirose Electric will not be responsible for any problems caused by use of tools other than specified.

Note 2: The manual crimping tool can be also used for cutting-off individual contacts from the reel.

Note 3: Customers that already have DF13 Series Hirose's press units and applicators will be able to use them for DF20 Series crimp terminations by replacing of only crimper and anvil.

Note4: The crimping tool for the DF20F-3032SCFA can also be used with the DF20F-2830SCFA.

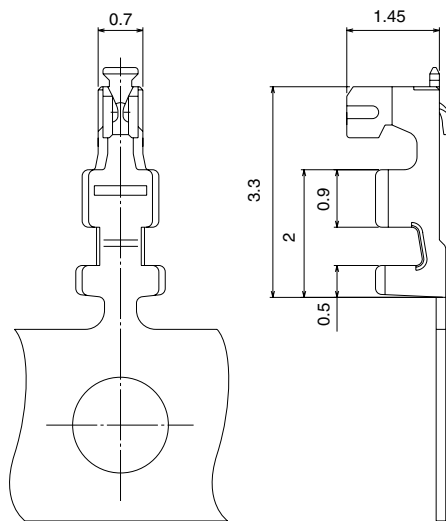

Replacement Parts List for Applicator

Type	Product No.	CL No.
Insulation crimper	AP105-DF20-2830S(61)	901-4572-6-61
Wire crimper	AP105-DF20-2830S(62)	901-4572-6-62
Insulation anvil and wire anvil	AP105-DF20-2830S(63)	901-4572-6-63

Double Row Straight Pin header

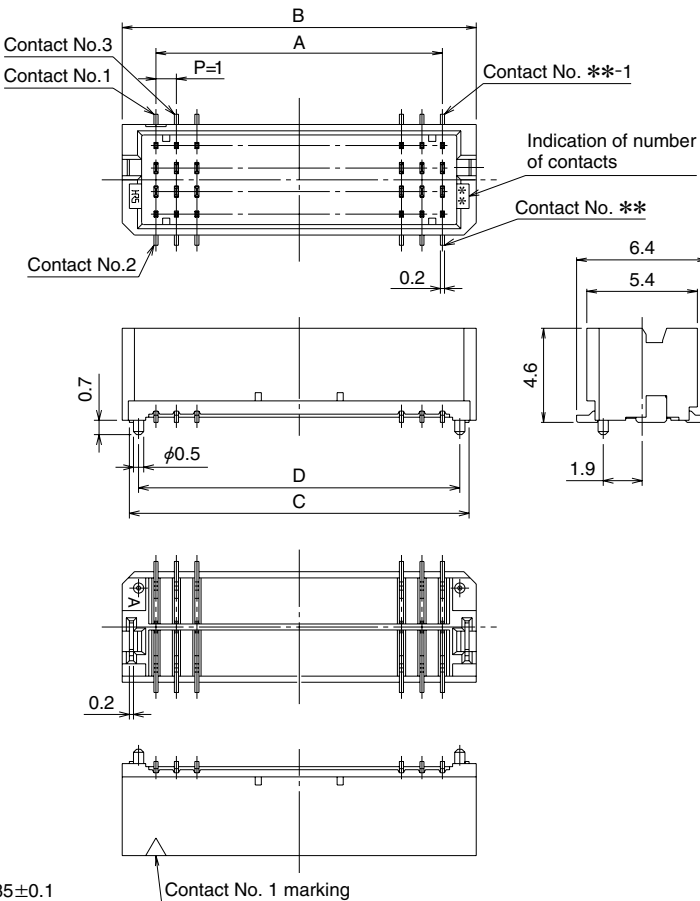
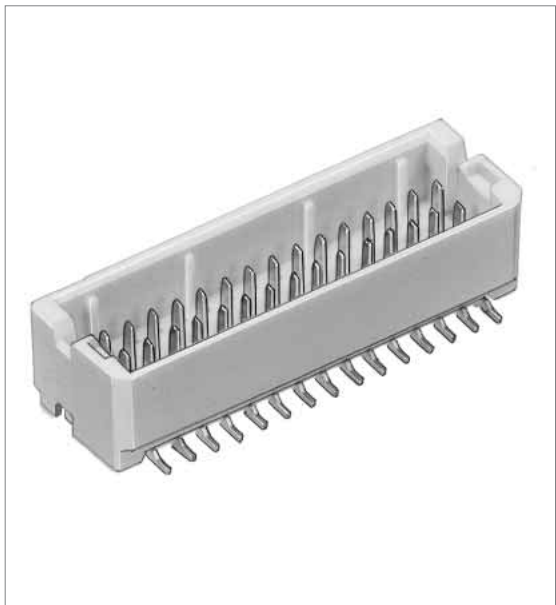

PCB Footprints

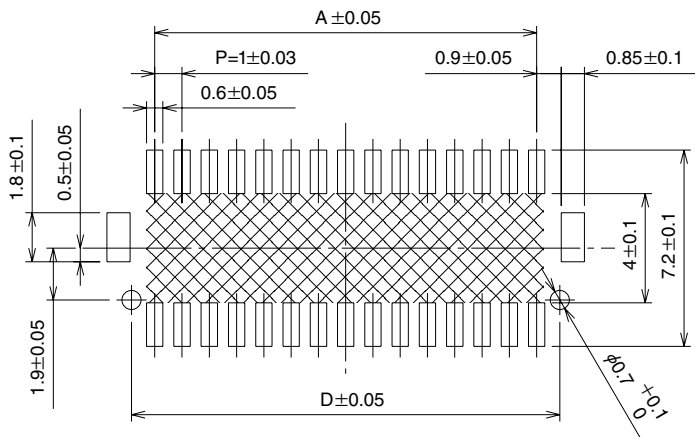

Note 1: Shaded area must be free of any electrically conductive traces to avoid contact with soldered pin header terminations.

Note 2: Required only for pin headers supplied with the positioning boss.

Unit: mm

Part Number	CL No.	No. of contacts	A	B	C	D	Remarks	RoHS
DF20F -10DP-1V(56)	CL686-0032-2-56	10	4.0	7.3	6.6	—	Without boss	YES
DF20F -20DP-1V(56)	CL686-0033-5-56	20	9.0	12.3	11.6	—		
DF20F -30DP-1V(56)	CL686-0034-8-56	30	14.0	17.3	16.6	—		
DF20F -40DP-1V(56)	CL686-0035-0-56	40	19.0	22.3	21.6	—		
DF20F -50DP-1V(56)	CL686-0036-3-56	50	24.0	27.3	26.6	—		
DF20G-10DP-1V(56)	CL686-0037-6-56	10	4.0	7.3	6.6	5.7	With boss	
DF20G-20DP-1V(56)	CL686-0038-9-56	20	9.0	12.3	11.6	10.7		
DF20G-30DP-1V(56)	CL686-0039-1-56	30	14.0	17.3	16.6	15.7		
DF20G-40DP-1V(56)	CL686-0040-0-56	40	19.0	22.3	21.6	20.7		
DF20G-50DP-1V(56)	CL686-0041-3-56	50	24.0	27.3	26.6	25.7		

Note1: Order embossed tape packaging items by the reel. (1 reel contains 1,000 pieces)

Note2: Vacuum pick-up cap are included with embossed tape packaged connectors.

[Specifications number]-*, (**)
 (56): Gold plating, embossed tape packaging

DF20 Series 1 mm Pitch Double Rows Low Profile Board-to-Cable Connectors

Double Row Right angle Pin header

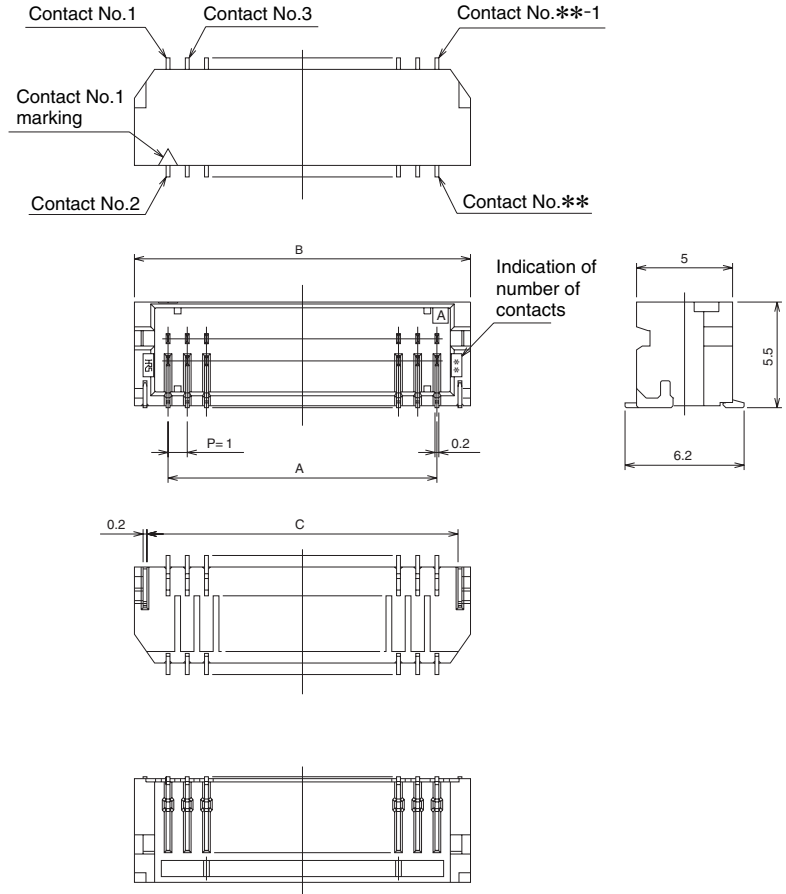

PCB Footprints

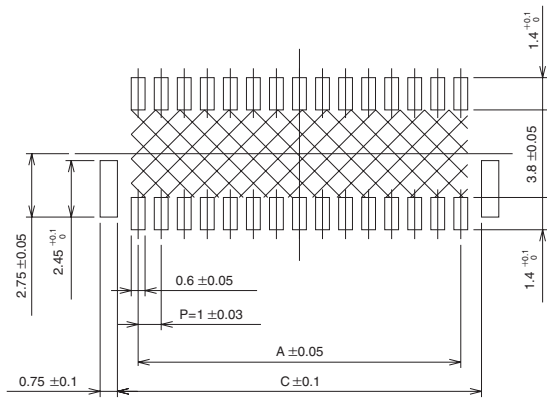

Note : Shaded area must be free of any electrically conductive traces to avoid contact with soldered pin header terminations.

Unit: mm

Part Number	CL No.	No. of contacts	A	B	C	Remarks	RoHS
DF20F -10DP-1H(59)	686-0027-2(59)	10	4.0	7.5	6.2	Without boss	YES
DF20F -20DP-1H(59)	686-0028-5(59)	20	9.0	12.5	11.2		
DF20F -30DP-1H(59)	686-0029-8(59)	30	14.0	17.5	16.2		
DF20F -40DP-1H(59)	686-0030-7(59)	40	19.0	22.5	21.2		

[Specifications number]-*, (**)
 (59): Gold plating,
 embossed tape packaging

Note: Order embossed tape packaging items by the reel. (1 reel contains 1,000 pieces)

◆ Embossed Carrier Tape Dimensions

● Straight pin header

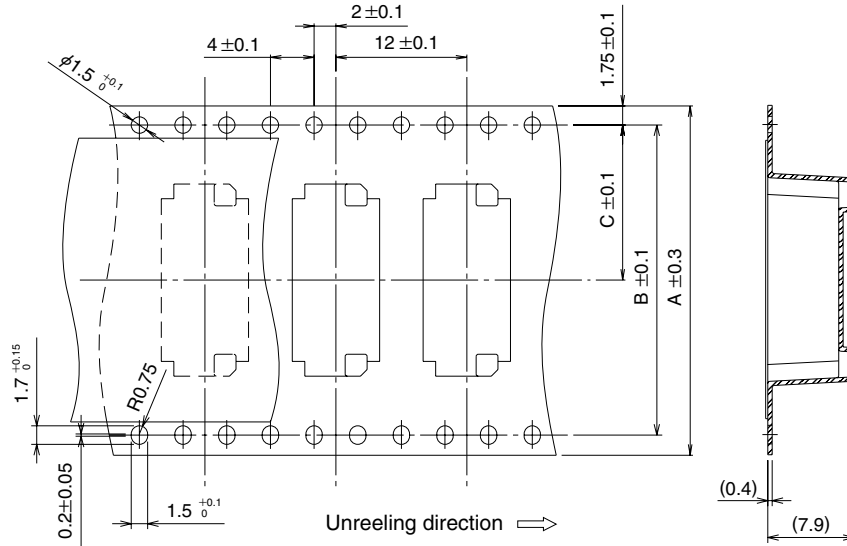

● Right angle pin header

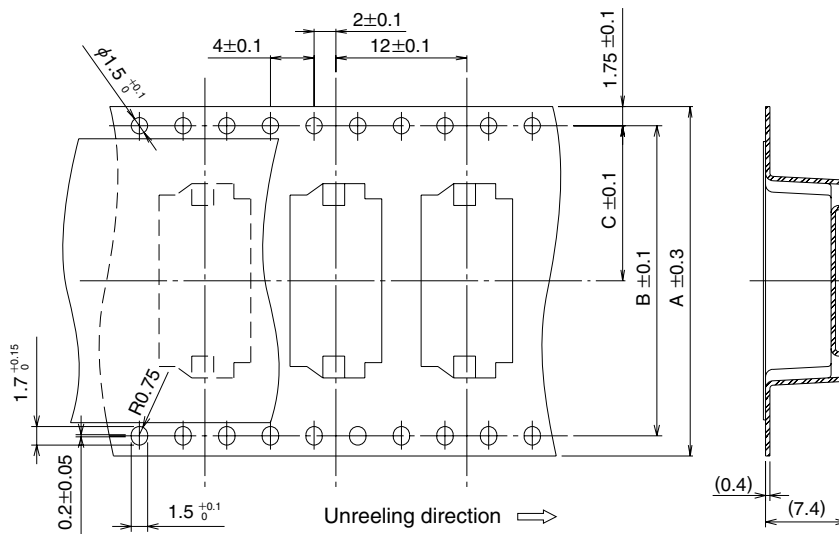

● Reel dimensions

Part Number	No. of Contacts	A	B	C	D
DF20F(G)-10DP-1V(56)	10	16	—	7.5	16.4
DF20F(G)-20DP-1V(56)	20	24	—	11.5	24.4
DF20F(G)-30DP-1V(56)	30	32	28.4	14.2	32.4
DF20F(G)-40DP-1V(56)	40	44	40.4	20.2	44.4
DF20F(G)-50DP-1V(56)	50	44	40.4	20.2	44.4
DF20F - 10DP-1H(59)	10	16	—	7.5	16.4
DF20F - 20DP-1H(59)	20	24	—	11.5	24.4
DF20F - 30DP-1H(59)	30	32	28.4	14.2	32.4
DF20F - 40DP-1H(59)	40	44	40.4	20.2	44.4

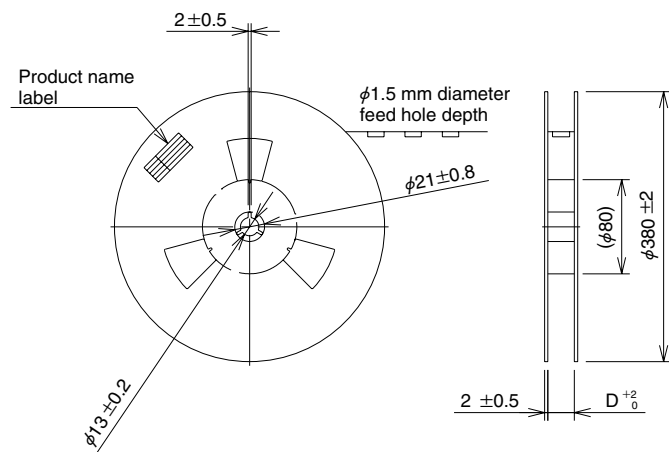

DF20 Series 1 mm Pitch Double Rows Low Profile Board-to-Cable Connectors

◆ Usage recommendation

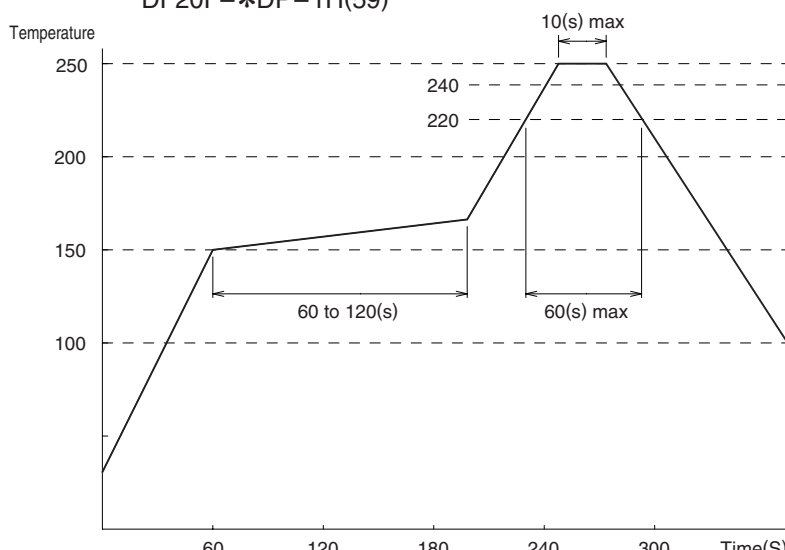
<p>1. Recommended Soldering Temperature Profile for IR Reflow.</p>	<div style="text-align: center;"> <p>DF20F- *DP- 1H(59)</p>  <p>The graph shows a temperature profile for IR reflow. The y-axis is Temperature (°C) from 100 to 250. The x-axis is Time (S) from 0 to 300. The profile starts at 100°C, rises to 150°C at 60s, then to 250°C at 240s. It has a dwell at 240°C for 10s max. The temperature then falls back to 100°C. A note indicates a 60 to 120s dwell at 150°C is possible.</p> </div> <p>Note 1: Up to 2 cycles of reflow soldering are possible under the same conditions, provided that there is a return to normal temperature between the first and second cycle. Note 2: The temperature indicates the board surface temperature at the points of contacts with the connector terminals.</p>
<p>2. Recommended Manual Soldering Conditions</p>	<p>Soldering temperature: 290°C ±10°C, Soldering time: within 3 sec.</p>
<p>3. Recommended Solder Screen Thickness</p>	<p>0.15mm</p>
<p>4. Board Warping</p>	<p>Maximum of 0.03 mm at the connector center section, with both ends of the connector as reference points.</p>
<p>5. Cleaning Conditions</p>	<p>Refer to "Nylon Connector Use Handbook."</p>
<p>6. Wiring Termination Conditions</p>	<p>Refer to "Nylon Connector Use Handbook." Crimp contacts should be handled with care as not to cause any deformation or damage affecting the performance or termination.</p>
<p>7. Mating / un-mating precautions</p>	<p>Excessive twisting and pulling on wires during mating/un-mating should be avoided as it may cause damage to connectors.</p>