

4

3

2

1

THIS DRAWING IS UNPUBLISHED. RELEASED FOR PUBLICATION. ALL RIGHTS RESERVED.

LOC	DIST	REVISIONS		DATE	BY	APP'D
CM	00	F	LR			
		D1		REVISED PER ECO-11-004820	11MAR11	RK HMR

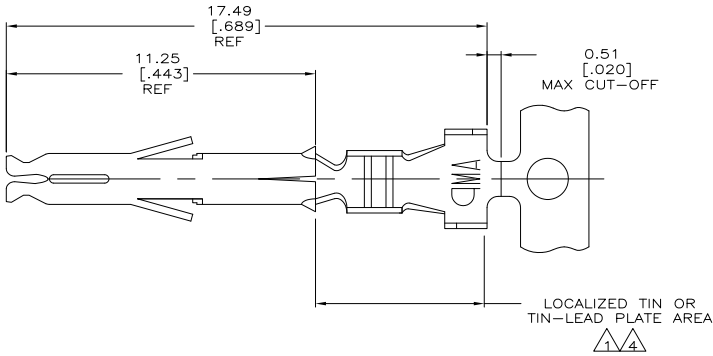

1. 0.00076 [.000030] MIN GOLD PER IN LOCALIZED GOLD PLATE AREA AND 0.00254-0.00635 [.000100-.000250] BRIGHT TIN-LEAD PER IN LOCALIZED TIN-LEAD PLATE AREA OVER 0.00127 [.000050] MIN NICKEL.

2. WIRE RANGE: 0.5-1.4MM² (20-16 AWG).

3. INSULATION RANGE: 2.01-3.20 [.079-.126] DIA.

4. 0.00076 [.000030] MIN GOLD PER IN LOCALIZED GOLD PLATE AREA AND 0.00254-0.00635 [.000100-.000250] MATTE TIN IN LOCALIZED TIN PLATE AREA OVER 0.00127 [.000050] MIN NICKEL.

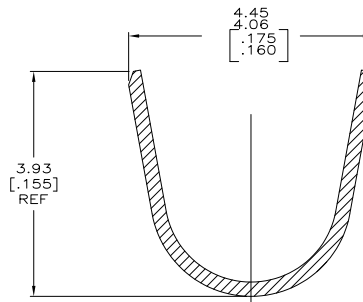
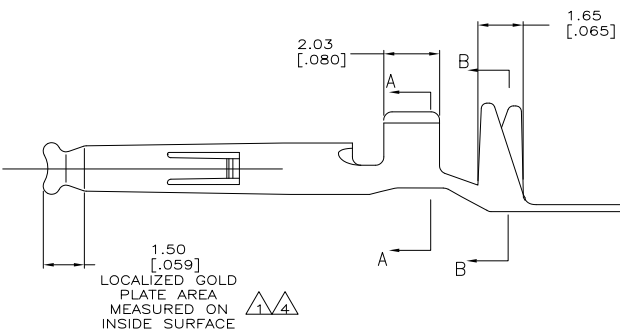

SECTION B-B
SCALE 20:1

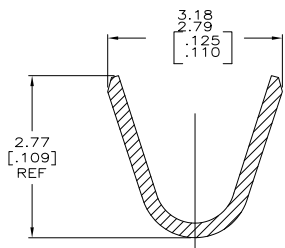

SECTION A-A
SCALE 20:1

△	0.20 [.008] PH BRZ	1-794407-1
△	0.20 [.008] BRASS	1-794407-0
△	0.25 [.010] PHOS BRONZE	794407-6
PRE-TIN	0.25 [.010] PHOS BRONZE	794407-4
△	0.25 [.010] BRASS	794407-3
PRE-TIN	0.25 [.010] BRASS	794407-1
FINISH	MATERIAL	PART NUMBER

DIMENSIONS		TOLERANCES UNLESS OTHERWISE SPECIFIED		FINISH		MATERIAL		PART NUMBER	
mm	[INCHES]	0 PLC	±	0	±	0	±	0	±
		1 PLC	±	1	±	1	±	1	±
		2 PLC	±	2	±	2	±	2	±
		3 PLC	±	3	±	3	±	3	±
		4 PLC	±	4	±	4	±	4	±
		ANGLES	±	ANGLES	±	ANGLES	±	ANGLES	±

METRIC