

4

3

2

1

THIS DRAWING IS UNPUBLISHED. RELEASED FOR PUBLICATION - N/A.
 © COPYRIGHT N/A BY TYCO ELECTRONICS CORPORATION. ALL RIGHTS RESERVED.

LOC		DISTR		REVISIONS			
DF	BO	P	LTR	DESCRIPTION	DATE	MIN	APD
		L		REV PER ECO-05-005359	14NOV05	PY	DE

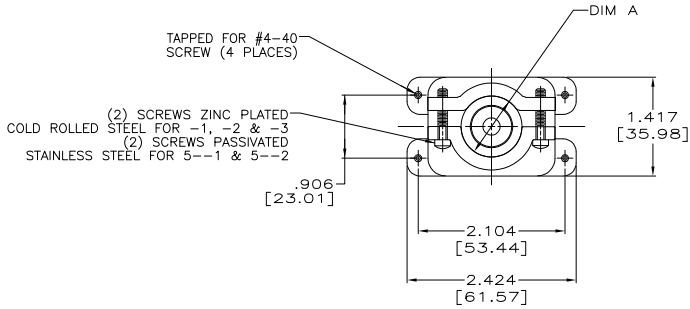

- ⚠ ZINC PLATE PER ASTM-B-633 TYPE II CLASS 3 COLORLESS SUPPLEMENTARY CHROMATE.
- ⚠ TWO RUBBER BUSHINGS SUPPLIED TO PROVIDE .250 [6.35], .625 [15.88], DIAMETER OUTLETS.
- ⚠ AMP, AMP PART NUMBER AND DATE CODE MARKED APPROXIMATELY AS SHOWN.
- 4. SHIELD TO ACCOMMODATE MODULE RECEPTACLE ASSEMBLY OR PLUG ASSEMBLY.
- ⚠ BULK PACKAGED.
- ⚠ PLATED ELECTROLESS NICKEL PER SAE-AMS-C-26074 .000400-.000800 THK (NO INTENTIONAL ADDITIONS OF LEAD OR CADMIUM PER DFE STANDARD 230-700).

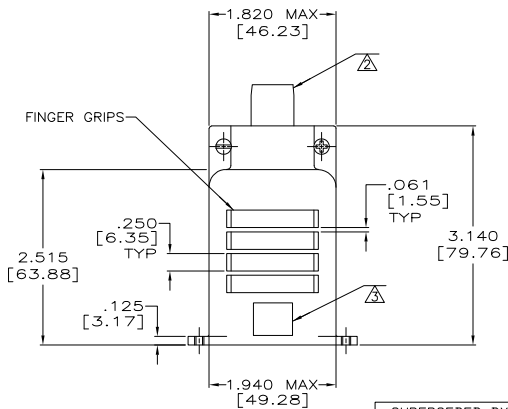

OBSOLETE
 SUPERSEDED BY 5-202617-2
 SUPERSEDED BY 5-202617-1

-	Ø.875	YES	NO	⚠	5-202617-2
-	Ø.875	YES	YES	⚠	5-202617-1
⚠	Ø.875	YES	YES	⚠	202617-4
-	Ø1.000	YES	NO	⚠	202617-3
-	Ø.875	YES	NO	⚠	202617-2
-	Ø.875	YES	YES	⚠	202617-1
REMARKS	DIM A	FINGER GRIPS BOTH SIDES	BUSHINGS	FINISH	PART NUMBER

THIS DRAWING IS A CONTROLLED DOCUMENT. **DM** T. THOMPSON 10-NOV-98
OK R. BELL 10-NOV-98
APD R. BELL 10-NOV-98

Tyco Electronics Tyco Electronics Corporation
 Harrisburg, Pa 17105-3608

**SHIELD FOR MODULE ASSEMBLY
 2 BLOCK ASSEMBLY**

APPLICATION SPEC: -
 WEIGHT: -
 SIZE: A2 CASE CODE: C-202617 DRAWING NO: -
 RESTRICTED TO: -

MATERIAL: ALUMINUM DIE CAST PER QQ-A-591 SEE TABLE
 FINISH: CUSTOMER DRAWING

SCALE: 1:1 SHEET: 1 OF 1 REV: L