

© 1974 BY AMP INCORPORATED. ALL RIGHTS RESERVED. AMP PRODUCTS COVERED BY PATENTS AND OR PATENTS PENDING. APPROVED PER GOVT CONTRACT NO.

REVISIONS				
SYM	ZONE	DESCRIPTION	DATE	APPROVAL
O		RELEASED WAS M5001-679	7/6/64	KY DSK
A		REVISED W-276	5-27-65	mm.s./D.H.
B		REMOVE PROPOSED DESIGN STAMP W-530	7-23-65	mm.s./D.H.
C		REVISED Y-68	1-18-66	mm.s./D.H.
D		ADDED "A" DIMEN & -2 ECN A-881	11/3/70	W.S.
D		REV PER ECN D-694	03/17/71	AK
E		REV PER ECO-05-001412	05/05	DA
F		REV PER ECO-05-005359	11/05	PY/DE
G		ECO-09-002648	PY	5-09 DE

SUPERSEDED BY 5-202567-1 202567-1 1. AS SHOWN.  
 2. "A" DIMENSION = .891

**OBSOLETE** 202567-2 1. SAME AS -1 EXCEPT:  
 2. "A" DIMENSION = 1.266

5-202567-1 1. SAME AS -1 EXCEPT =  
 2. PLATED ELECTROLESS NICKEL PER SAE-AMS-C-207A .000400-.000800 THK (NO INTENTIONAL ADDITIONS OF LEAD OR CADMIUM PER SPE STD Z90-100).  
 3. "A" DIMENSION = .891

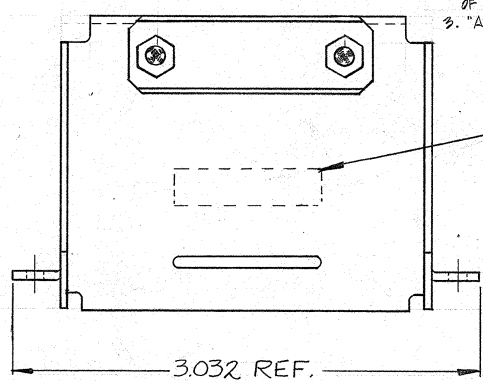
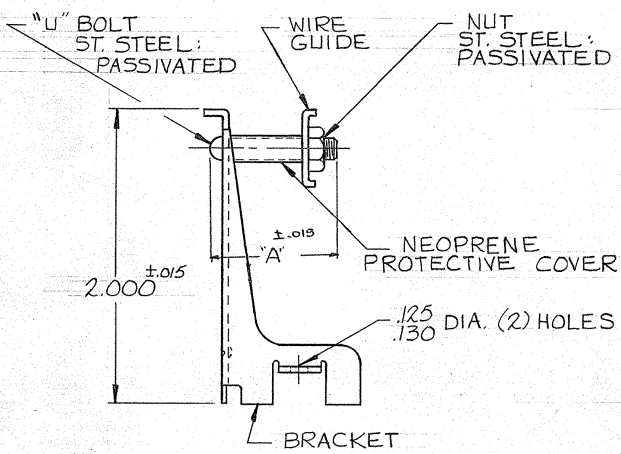

INK STAMP  
 "AMP" & ASSY. NO.  
 & DATE CODE IN  
 THIS AREA ON  
 OPPOSITE SIDE,

NOTE:  
 © 1. ZINC PLATE PER ASTM-B-688 CLASS 3 TYPE II.  
 COLORLESS SUPPLEMENTARY CHROMATE.

AMP INFO		QTY		NOMENCLATURE OR		PART OR	
LOC PRINT DIE		REQD		DESCRIPTION		IDENTIFYING NO.	
LIST OF MATERIALS OR PARTS LIST							
UNLESS OTHERWISE SPECIFIED DIMENSIONS ARE IN INCHES TOLERANCES ON FRACTIONS DECIMALS ANGLES = .005				SIGNATURE		DATE	
MATERIAL C. R. STEEL				DR. K. Jones		7/6/64	
HEAT TREAT				CHK. S. Heide		7/6/64	
FINISH				DSGN ENGR. J. White		7/22/64	
SEE NOTE 1				APP. J. White		7/22/64	
OTHER APPD				DSGN APPD		CODE IDENT NO. 00779	
				OTHER APPD		SIZE C NUMBER 202567	
				SCALE 2-1		REV G	
				WT		CALC	
				ACTUAL		SHEET	

CUSTOMER DRAWING