

# Ultra Low-profile Interface Connectors with 2.0 mm Mounting Height

## LX Series

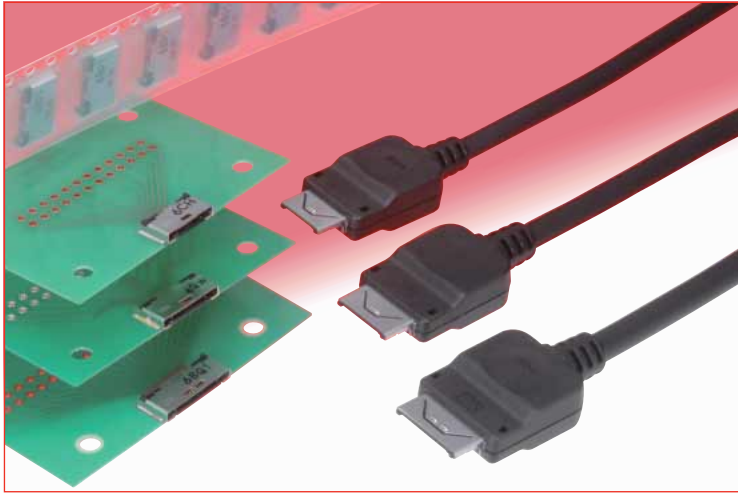

### Features

#### 1. Low profile on the PCB

When mounted on the PCB surface the receptacle height is 2.0 mm.

#### 2. Strong Construction

Use of metal shell and advanced plastics guarantees that fully mated connectors will withstand 30 N max. force applied on the plug in any direction.

#### 3. High durability

5000 mating/un-mating cycles without any degradation of electrical or mechanical performance.  
Tactile sensation when mating confirms complete mated condition and assures secure retention of the plug.

#### 4. Sequenced contact mating

The protection of the circuit is assured by having the 2 contact at each end of the receptacle protrude forward by 0.5 mm, with electrical wipe of 1.45 mm. Location of the circuit protection contacts can be changed as required.  
Remaining contacts electrical wipe is 0.95 mm.

#### 5. Incorrect Insertion Prevention

Connectors will not be damaged when angled or reverse plug insertion is attempted.

#### 6. Safety plug release

Plug will release when an excessive pull force is applied to the cable.

#### 7. RoHS Compliant

All components and materials comply with the requirements of the EU Directive 2002/95/EC.

### Overview

Hirose's next generation of interface connectors further reduces the mounting height of the receptacle by approximately 30% (compared with the 3200 Series receptacle).

High durability, secure mating, electrostatic protection and ease of operation guarantees reliable and consistent performance in demanding consumer applications.

### Lower Profile



### Strong Construction

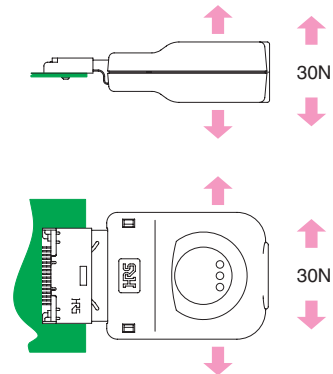

### Incorrect insertion prevention

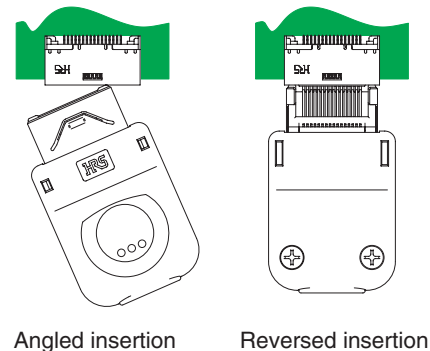

## LX Series Ultra Low-profile Interface Connectors with 2.0 mm Mounting Height

### Product specifications

Ratings	Current rating	0.5A (1A max. can be carried via 2 random contacts)	Operating temperature range : -40°C to +70°C
	Voltage rating	50V AC	Storage temperature range : -55°C to +85°C (Note)

Characteristic	Specification	Conditions
1. Contact resistance	70mΩ max.	100mA DC
2. Insulation resistance	1000 MΩ min. (dry) 10 MΩ min. (high humidity)	100V DC
3. Withstanding voltage	No flashover or insulation breakdown.	250V AC / one minute
4. Mating/un-mating forces	Mating: 10N max., un-mating: 4N min.	With corresponding connector.
5. Durability (mating/un-mating)	Amount of change of contact resistance: 20mΩ max.	5, 000 times
6. Shock	No electrical discontinuity of 1μ sec. Max. Contact resistance: 20mΩ max.	Acceleration of 490 m/s <sup>2</sup> , 11 ms duration, sine half-wave waveform, 3 cycles, 3 axis.
7. Vibration	Contact resistance: 20mΩ max. Insulation resistance: 10MΩ min.	Frequency: 10 to 55 Hz, single amplitude of 0.75 mm, acceleration of 98 m/s <sup>2</sup> , 2 hours, 3 axis.
8. Temperature cycle	Contact resistance: 20mΩ max. Insulation resistance: 10MΩ min.	Temperature: -55°C → +5°C to +35°C → +85°C → +5°C to +35°C Time : 30 → 5 → 30 → 5 (Minutes)
9. Salt spray	No heavy corrosions	5% water solution at 35°C for 48 hours

Note : Includes temperature rise caused by current flow.

### Materials / Finish

#### Receptacles

Component	Material	Finish/Color	Remarks
Insulator	Synthetic resin	Black	UL94V-0
Contacts	Copper alloy	Contact area: Gold plated Mounting area: Gold flash plated	—
Shell	Stainless steel	Soldering area: Gold flash plated	—

#### Plugs

Component	Material	Finish/Color	Remarks
Insulator	Synthetic resin	Black	UL94V-0
Contacts	Copper alloy	Contact area: Gold plated Termination area: Gold flash plated	—
Metal shield	Stainless steel	—	—
Covers	Synthetic resin	Black	UL94V-0
Strain relief clamp	Copper alloy	—	—
Self tapping screws	Steel	Trivalent black chromate	Screw size: M2

### Ordering information

#### Receptacles

**LX 60 - 16 S**

① ② ③ ④

#### Plugs

**LX 40 - 16 P**

① ② ③ ④

#### Bushing

**LX 40 - 16 BS(4.5)**

① ② ③ ⑤

①	Series number : LX
②	Termination type 40 : Solder type 60 : Right angle SMT
③	Number of contacts : 12, 16, 20
④	Contact type P : Male contact (Plug) S : Female contact (Receptacle)
⑤	Bushing : Dia. 4.0mm cable BS(4.0) BS(4.5) BS(5.0)



**LX Series Ultra Low-profile Interface Connectors with 2.0 mm Mounting Height**

**Plugs**



Part number	CL No.	Packaging	RoHS
LX40-12P	CL245-0019-6	1	YES
LX40-16P	CL245-0002-3		
LX40-20P	CL245-0017-0		

●12 pos.

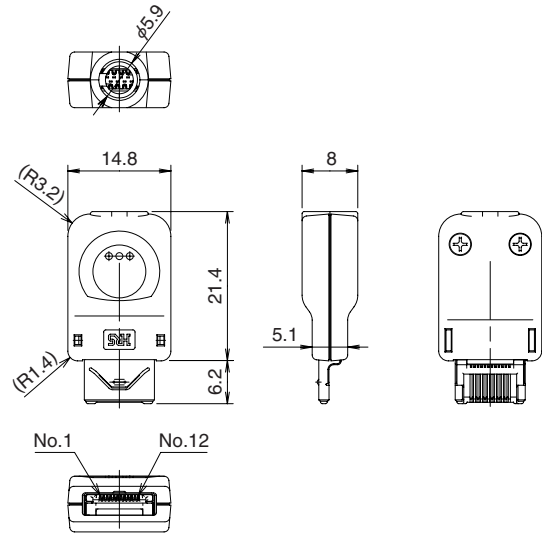

●16 pos.

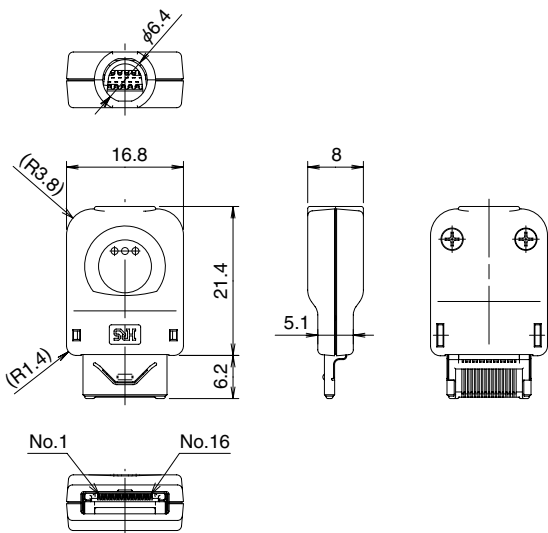

●20 pos.

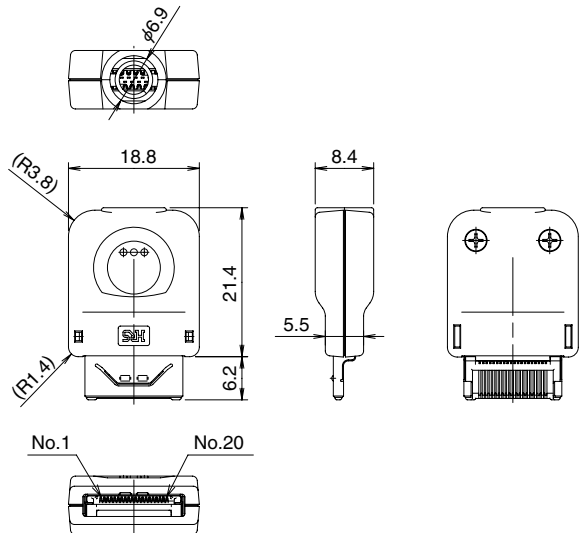

**Bushing**



Part number	CL No.	Packaging	RoHS
LX40-12BS(4.0)	CL245-0020-5	100 pieces / bag	YES
LX40-16BS(4.5)	CL245-0021-8		
LX40-20BS(5.0)	CL245-0022-0		

## ◆ Receptacle Packaging Specifications

### ● Embossed carrier tape dimensions

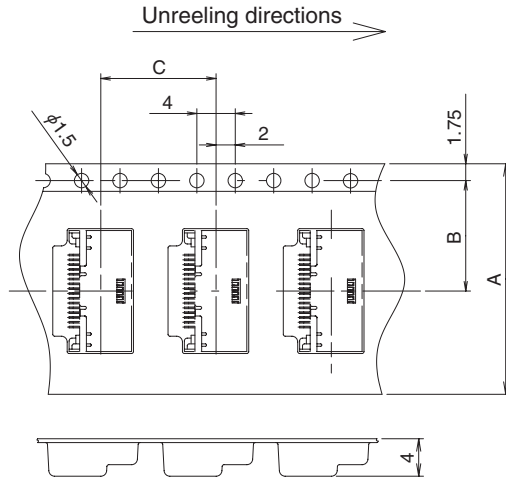

(mm)

Part number	A	B	C
LX60-12S	24	11.5	12
LX60-16S			
LX60-20S			

### ● Reel dimensions

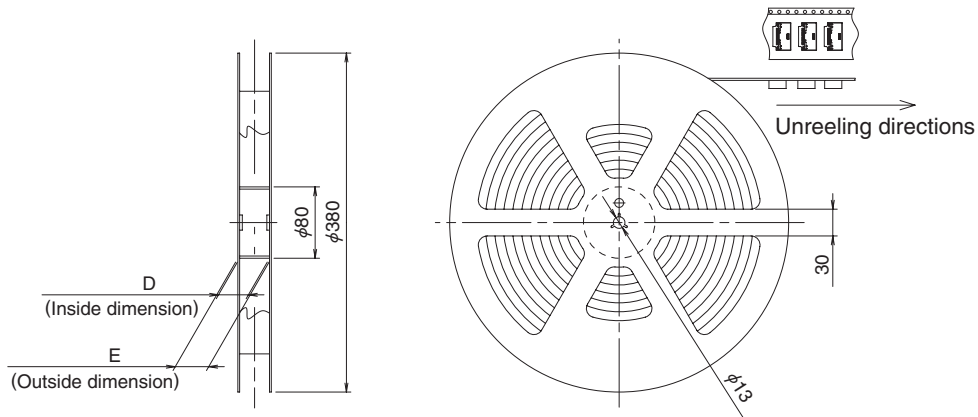

(mm)

Part number	D	E
LX60-12S	25.5	29.5
LX60-16S		
LX60-20S		

**LX Series Ultra Low-profile Interface Connectors with 2.0 mm Mounting Height**

**Receptacles Recommended Temperature Profile**

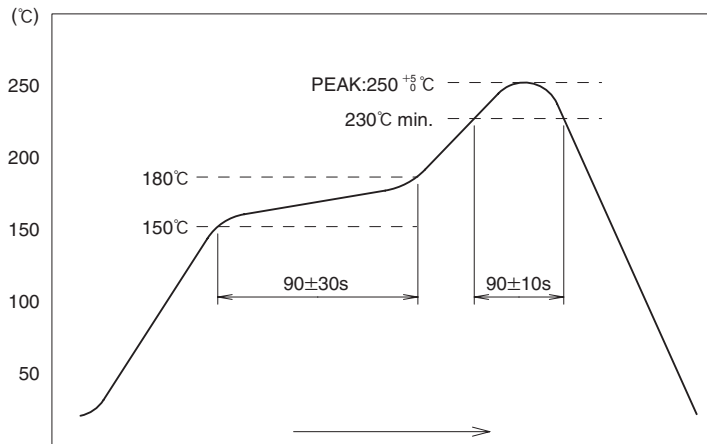

**HRS test conditions**

Solder composition

Paste, 96.5%Sn/3.0%Ag/0.5%Cu

Test board

Glass epoxy 35mm x 35mm x 0.8mm thick

The temperature profiles are based on the above conditions. In individual applications the actual temperature may vary, depending on solder paste type, volume/thickness and board size/thickness. Contact your solder paste and equipment manufacture for specific recommendations.

**Applicable Plug Cable**

Part number	Cable diameter	Wire size
LX40-12P	φ4 max.	φ0.6 mm max. (AWG 30 to 32 or equivalent)
LX40-16P	φ4.5 max.	
LX40-20P	φ5 max.	

- Note 1: Applicable cable sizes are guidelines. (There may be slight differences depending on the cable outer insulation)
- Note 2: Cables must be attached using single piece overmolded bushings on the cable.
- Note 3: Please refer to applicable Cable Termination Procedures Manual for correct plug assembly and cable termination.
- Note 4: Contact HRS for cable assemblies.

**Mated Condition Dimensions**

