

DRAWING MADE IN THIRD ANGLE PROJECTION

© COPYRIGHT 1977 BY AMP INCORPORATED, HARRISBURG, PA.
 ALL INTERNATIONAL RIGHTS RESERVED. AMP INCORPORATED PRODUCTS
 COVERED BY U. S. AND FOREIGN PATENTS AND/OR PATENTS PENDING.

⚠ SHEET METAL SCREWS NOT SUPPLIED
 TWO REQUIRED PER CONNECTOR.
 FOR USE WITH 2,3+4 CIRCUIT HOUSINGS WITH A MAXIMUM
 WIRE BUNDLE DIAMETER OF 5/16".

		REVISIONS			
P	F	ZONE/LTR	DESCRIPTION	DATE	APPROVED
✓	✓	C	REV PER EC 0730-0201-94	4/25/80	JH RS

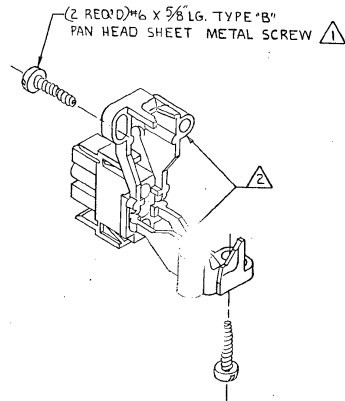
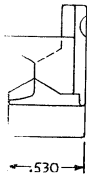
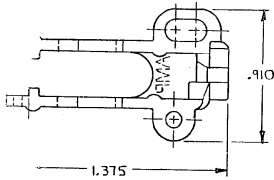
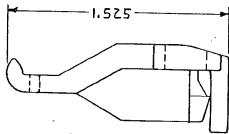

AMP 1471-6 REV 12-76

UNLESS OTHERWISE SPECIFIED DIMENSIONS ARE IN INCHES. TOLERANCES ON: DECIMALS ± .015 ANGLES ± —		CONTRACT NO	350811-1 PART NO	
MATERIAL NYLON 94V-0	DR M. FEHER 2-19-80	NAME AMP INCORPORATED Harrisburg, Pa.	STRAIN RELIEF FOR UNIVERSAL MATE-N-LOK HOUSING	
	CHK D. S. Hilde 2/29/80	SIZE CODE IDENT NO DRAWING NO	C 00779 350811	
	APPD JCR 2-29-80	SCALE 2-1	SHEET	
	OTHER APPD	CUSTOMER DRAWING		