

4

3

2

1

THIS DRAWING IS UNPUBLISHED. RELEASED FOR PUBLICATION
 © COPYRIGHT - By - ALL RIGHTS RESERVED.

LOC		DIST		REVISIONS			
P	LTR	DESCRIPTION		DATE	DWN	APVD	
DF	DO	F1	REVISED PER ECO-11-005030	23MAR11	RK	HMR	

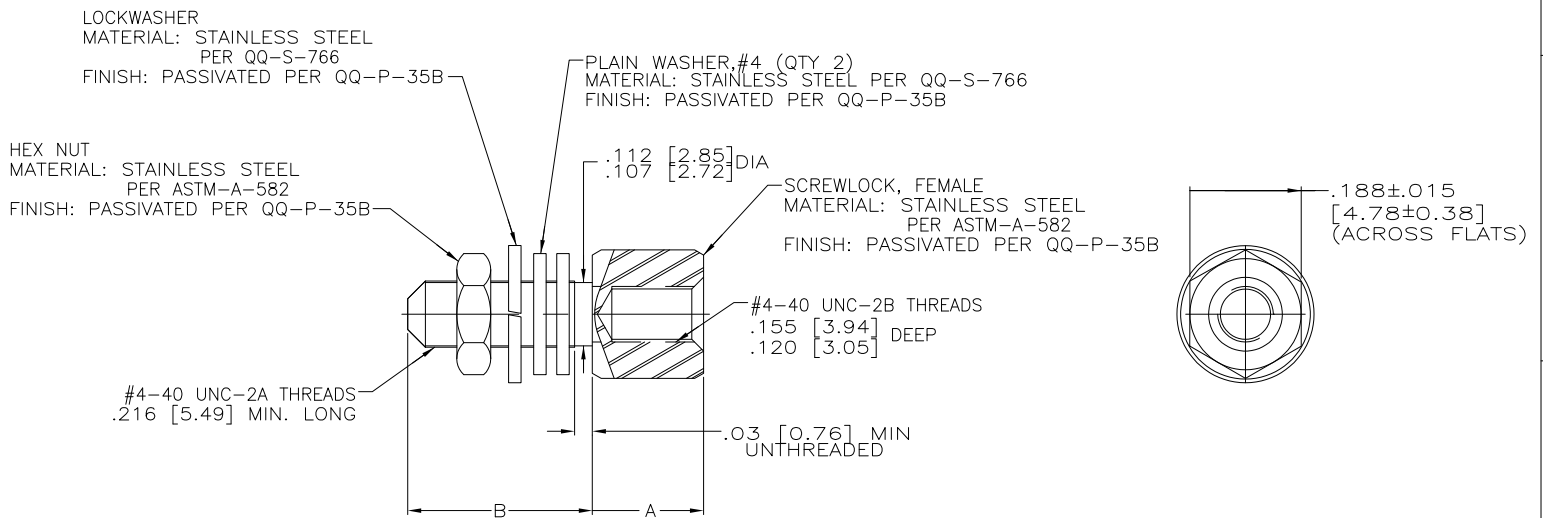

1. PACKAGED UNASSEMBLED.
2. EACH KIT HAS TWO COMPLETE ASSEMBLIES AS SHOWN ABOVE.
3. WHEN A CLINCH TAB TYPE CONNECTOR IS FRONT MOUNTED, ONE FLAT WASHER SHALL BE USED AS A SPACER BETWEEN THE MOUNTING SURFACE AND THE CONNECTOR.

.560 [14.22]	.223 [5.66]	-	212447-2
.312 [7.92]	.188 [4.78]	M24308/26-1P	212447-1
B .015 [0.38]	A .015 [0.38]	MILITARY PART NO	PART NO

THIS DRAWING IS A CONTROLLED DOCUMENT.		DWN J.LINDERMAN 1-6-93	TE Connectivity	
DIMENSIONS: INCHES[MM]		CHK F.KINSEY 1-8-93		
TOLERANCES UNLESS OTHERWISE SPECIFIED:		APVD F.KINSEY 1-8-93	NAME KIT, SCREWLOCK ASSEMBLY, FEMALE STAINLESS STEEL, AMPLIMITE	
0 PLC ± - 1 PLC ± - 2 PLC ± - 3 PLC ± - 4 PLC ± - ANGLES ± -		PRODUCT SPEC	RESTRICTED TO	
MATERIAL SEE CALLOUTS	FINISH SEE CALLOUTS	APPLICATION SPEC	SIZE A3	CAGE CODE 00779
		WEIGHT	DRAWING NO C=212447	SCALE 6:1
		CUSTOMER DRAWING		SHEET 1 OF 1
				REV F1