

DRAWING MADE IN THIRD ANGLE PROJECTION

THIS DRAWING IS UNPUBLISHED. RELEASED FOR PUBLICATION  
COPYRIGHT © 19 BY AMP INCORPORATED, HARRISBURG, PA. ALL INTERNATIONAL RIGHTS RESERVED. AMP PRODUCTS MAY BE COVERED BY U.S. AND FOREIGN PATENTS AND/OR PATENTS PENDING.

REVOLUTIONS		DATE	APPROVED
P	F		
A	A	REV ECN AA-3439	24-11-50 SD

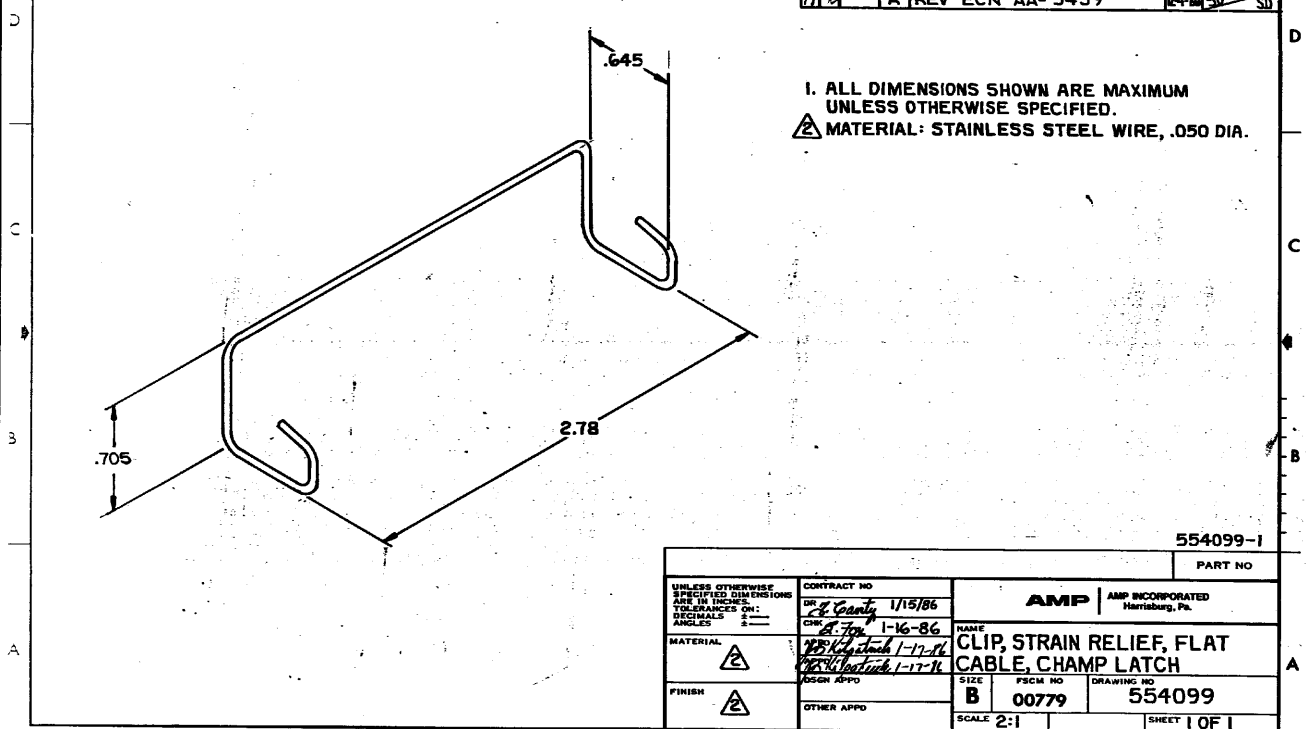

1. ALL DIMENSIONS SHOWN ARE MAXIMUM UNLESS OTHERWISE SPECIFIED.  
 ⚠ MATERIAL: STAINLESS STEEL WIRE, .050 DIA.

554099-1

UNLESS OTHERWISE SPECIFIED DIMENSIONS ARE IN INCHES. TOLERANCES ON: DECIMALS .005 ANGLES 2°		CONTRACT NO OR <i>A County</i> 1/15/86	AMP INCORPORATED Harrisburg, Pa.	
MATERIAL	⚠	CRW <i>A. J. 1-16-86</i>	NAME	CLIP, STRAIN RELIEF, FLAT CABLE, CHAMP LATCH
FINISH	⚠	<i>W. K. 1-17-86</i> <i>W. K. 1-17-86</i>	SIZE	B
		OTHER APPD	PSCM NO	00779
			DRAWING NO	554099
			SCALE	2:1
			SHEET	1 OF 1

AMP 1470-15 REV 2-81

CUSTOMER DRAWING