

4

3

2

1

THIS DRAWING IS UNPUBLISHED. RELEASED FOR PUBLICATION  
 © COPYRIGHT - BY TYCO ELECTRONICS CORPORATION. ALL RIGHTS RESERVED.

LOC		DIST		REVISIONS			
P	LTR	DESCRIPTION		DATE	DWN	APVD	
0		RELEASED PER EC 0S13-0207-05		12JUL05	SW	JG	

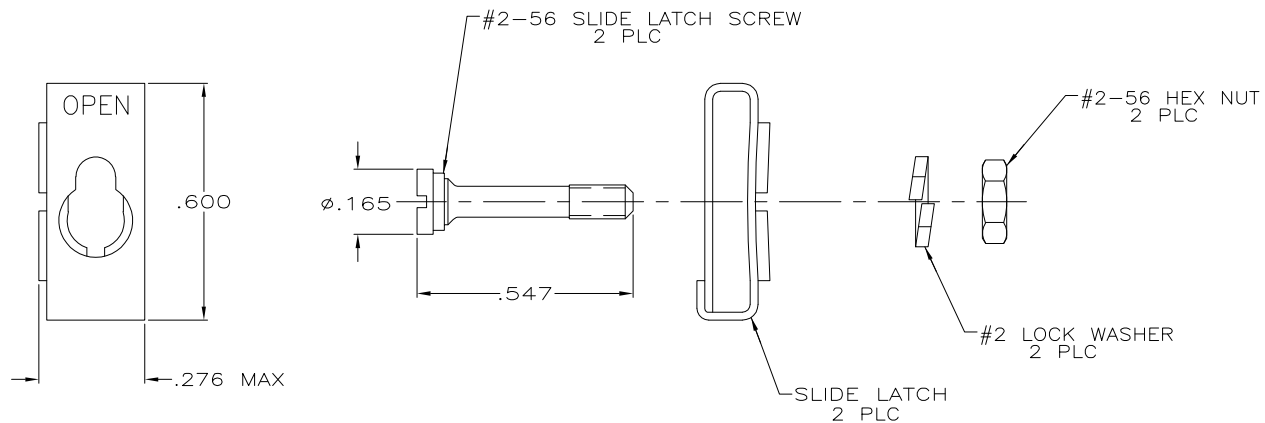

1. PARTS PACKAGED UNASSEMBLED.
2. PARTS PACKAGED AS A UNIT KIT.
3. ZINC PLATED .000200-.000400 THICK, CLEAR CHROMATE COATING.
4. THIS KIT CAN BE USED WITH TWO-PIECE STRAIGHT/90° EXIT CABLE CLAMPS, RFI/EMI CABLE CLAMPS, AND UNIVERSAL CABLE CLAMPS.

5748078-1  
 PART NO

THIS DRAWING IS A CONTROLLED DOCUMENT.		DWN	S. WAITMAN	12JUL05		Tyco Electronics Corporation																		
DIMENSIONS: INCHES		CHK	C. ROHDE	12JUL05		Harrisburg, Pa 17105-3608																		
TOLERANCES UNLESS OTHERWISE SPECIFIED:		APVD	M. WALMSLEY	12JUL05	NAME	KIT, TWO-PIECE SLIDE LATCH, SIZES 1 THRU 4, AMPLIMITE																		
<table border="1"> <tr><td>0 PLC</td><td>± -</td></tr> <tr><td>1 PLC</td><td>± -</td></tr> <tr><td>2 PLC</td><td>± -</td></tr> <tr><td>3 PLC</td><td>± .005</td></tr> <tr><td>4 PLC</td><td>± -</td></tr> <tr><td>ANGLES</td><td>± -</td></tr> </table>		0 PLC	± -	1 PLC	± -	2 PLC	± -	3 PLC	± .005	4 PLC	± -	ANGLES	± -	PRODUCT SPEC	-		SIZE	A3	CAGE CODE	00779	DRAWING NO	5748078	RESTRICTED TO	-
0 PLC	± -																							
1 PLC	± -																							
2 PLC	± -																							
3 PLC	± .005																							
4 PLC	± -																							
ANGLES	± -																							
MATERIAL: SLIDE LATCH: STAINLESS STEEL HARDWARE: STEEL		FINISH	-		WEIGHT	-		-		CUSTOMER DRAWING	SCALE	4:1	SHEET	1	OF	1	REV	0						