

4

3

2

1

THIS DRAWING IS UNPUBLISHED. RELEASED FOR PUBLICATION
 © COPYRIGHT 2006 BY TYCO ELECTRONICS CORPORATION. ALL RIGHTS RESERVED.

LOC	DIST	REVISIONS			
P	LTR	DESCRIPTION	DATE	DWN	APVD
GP	00	A	REVISED PER EC 0S13-0389-05	09MAR06	JG JG

M3x0.5 THREAD
 LATCHING BLOCK

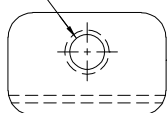

- PARTS PACKAGED UNASSEMBLED, 1 KIT PER BAG. EACH KIT CONTAINS 2 OF EACH COMPONENT.
- LATCHING BLOCK: ZINC ALLOY.
- SCREW: ZINC PLATED .000200-.000400 THICK, CLEAR CHROMATE COATING.

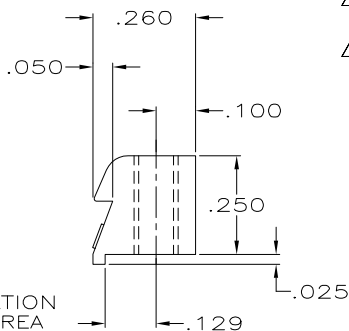
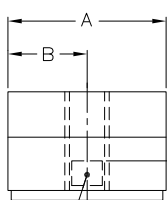

THREAD IDENTIFICATION LOCATED IN THIS AREA

M3x0.5 THREAD
 PAN HEAD SCREW

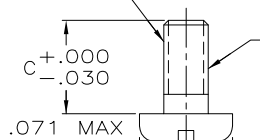

.236	.200	.400	5745007-1
C	B	A	PART NUMBER

THIS DRAWING IS A CONTROLLED DOCUMENT.		DWN J.GERACE 01MAR06	Tyco Electronics Corporation Harrisburg, PA 17105-3608	
DIMENSIONS: INCHES		CHK C.ROHDE 01MAR06	NAME M.WALMSLEY	
TOLERANCES UNLESS OTHERWISE SPECIFIED:		APVD M.WALMSLEY 01MAR06	PRODUCT SPEC ---	
0 PLC ± -		APPLICATION SPEC ---	RESTRICTED TO ---	
1 PLC ± -		WEIGHT ---	SIZE A3	CAGE CODE 00779
2 PLC ± -		FINISH ---	DRAWING NO C-5745007	SCALE 4:1
3 PLC ± .010		MATERIAL ---	SHEET 1 OF 1	
4 PLC ± -		FINISH ---	REV A	
ANGLES ± -		CUSTOMER DRAWING		

AMP 1470-19 REV 31MAR2000

09MAR06 2:41pm us012439

H:\dmmod\5745007_1-c.dwg