

4

3

2

1

THIS DRAWING IS UNPUBLISHED. RELEASED FOR PUBLICATION 19JUNE, 2006.  
 © COPYRIGHT 2006 BY TYCO ELECTRONICS CORPORATION. ALL RIGHTS RESERVED.

| LOC | DIST | REVISIONS     |          |     |      |
|-----|------|---------------|----------|-----|------|
| P   | LTR  | DESCRIPTION   | DATE     | DWN | APVD |
| D   |      | ECR-06-014842 | 19/06/06 | AM  | FWK  |

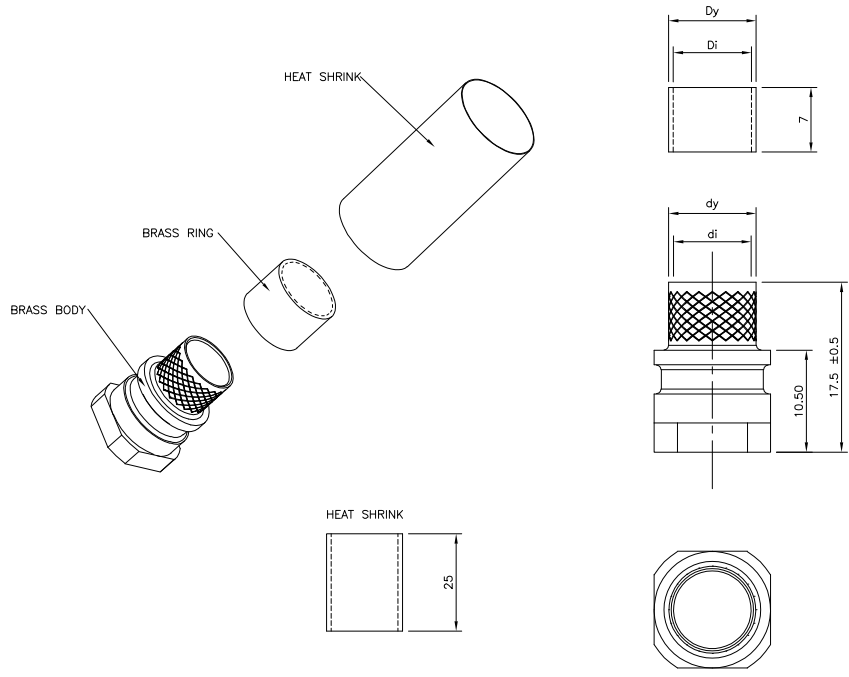

⚠ BULK PACKAGED CRIMP KIT ASSEMBLIES. CRIMP KIT ASSEMBLY COMPONENTS PACKAGED SEPARATELY IN BAGS. 100 COMPONENTS PER BAG. 1 BOX CONTAINS 100 ASSEMBLIES.  
 2. FOR APPLICATION DETAILS REFER TO LEAFLET 1478531-1. 1-PER BOX OF 100 PARTS

|             |    |    |    |    |               |
|-------------|----|----|----|----|---------------|
| 1478764-4   | 8  | 9  | 10 | 11 | 9.5mm DIA     |
| 1478764-3   | 7  | 8  | 9  | 10 | 8.5mm DIA     |
| 1478764-2   | 6  | 7  | 8  | 9  | 7.5mm DIA     |
| 1478764-1   | 4  | 5  | 6  | 7  | 6.0mm DIA     |
| PART NUMBER | di | dy | Di | Dy | CABLE MAX DIA |

| COMPONENTS/BAG | DESCRIPTION           | PART NUMBER |   |
|----------------|-----------------------|-------------|---|
| 100            | CRIMP KIT 9.5mm CABLE | 1478764-4   | ⚠ |
| 100            | CRIMP KIT 8.5mm CABLE | 1478764-3   | ⚠ |
| 100            | CRIMP KIT 7.5mm CABLE | 1478764-2   | ⚠ |
| 100            | CRIMP KIT 6mm CABLE   | 1478764-1   | ⚠ |

THIS DRAWING IS A CONTROLLED DOCUMENT.

| DIMENSIONS: | TOLERANCES UNLESS OTHERWISE SPECIFIED: |
|-------------|--|
| mm          |  |
| 0 PLC       | ± -                                    |
| 1 PLC       | ± -                                    |
| 2 PLC       | ± -                                    |
| 3 PLC       | ± -                                    |
| 4 PLC       | ± -                                    |
| ANGLES      | ± -                                    |
| MATERIAL    | FINISH                                 |
| -           | -                                      |

|                                   |  |
|-----------------------------------|--|
| DWN<br>A.Morey<br>19JUN2006       | Tyco Electronics Corporation<br>Bideford, UK, EX39 4HE |
| CHK<br>F.Wheeler-King<br>20JUN06  |  |
| APVD<br>F.Wheeler-King<br>20JUN06 | NAME   |
| PRODUCT SPEC                      | CRIMP KIT FOR ADK SERIES                               |
| APPLICATION SPEC                  |  |
| WEIGHT                            | SIZE CAGE CODE DRAWING NO RESTRICTED TO                |
| -                                 | A3 00779 C-1478764 -                                   |
| CUSTOMER DRAWING                  | SCALE NTS SHEET 1 OF 1 REV D                           |