

NUMBER C-178877

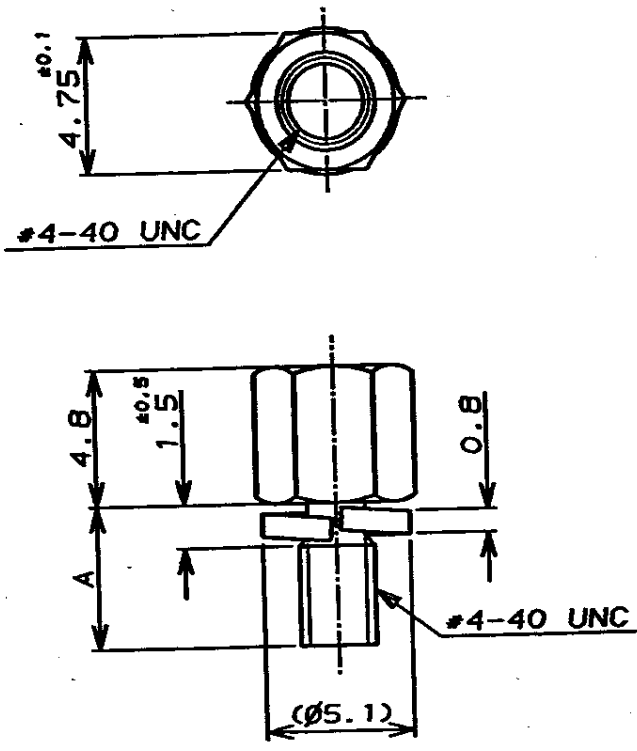

METRIC



注記

- 1. 材料：鋼
- 2. 仕上げ：ニッケルめつき
- 3. スクリューロック取付け時の締め付けトルク：5kg-cm以下

NOTES

- 1. MATERIAL: CARBON STEEL
- 2. FINISH: NICKEL PL.
- 3. SCREWLOCK TORQUE WHEN MOUNTED: 5kg-cm MAX.

ALL DIMENSIONS IN MM. DO NOT SCALE PRINT

7.9	↑ -2
5	178877-1
A	P/N

Copyright ©19 年 AMP (Japan), LTD. ALL RIGHTS RESERVED.		Copyright ©19 年 AMP (Japan), LTD. ALL RIGHTS RESERVED.		AMP 日本エー・エム・ピー株式会社 Tokyo, Japan	
一般公差 (GENERAL TOLERANCE)		線径公差範囲 (WIRE RANGE)		被覆外径 (INSULATION DIA.)	
10mm以下: ±0.2		mm ² (AWG)		mm	
10mm以上, 30mm以下: ±0.25		材料 (MATERIAL)		仕上 (FINISH)	
30mm以上, 100mm以下: ±0.3		角 度: ±3°			
A	ADDED	J-1617	H.K.Y.	6/JUL/91	
0	RELEASED	J-0133	Y.K.Y.K.	6/JUL/91	
LTR	変更 (REVISION RECORD)	DR	CHK	DATE	
DR.	Y. KODAIRA	DE.	Y. KASHIWA	6/JUL/91	
CHK.	Y. KASHIWA	APP.	R. NISHIMURA	6/JUL/91	
尺度 (SCALE)	SIZE	LOC	番号 (No.)	REV.	SHEET
4-1	A4	J	C-178877	A	1 OF 1
名称 (NAME) スクリーンロック スプリングワッシャー付き アンプリマイト SCREWLOCK WITH SPRING WASHER AMPLIMITE					