

A: MATERIAL
 1. HOUSING: THERMOPLASTIC
 2. TERMINAL: COPPER ALLOY
B: CHARACTERISTICS:
 1. RATING: 16A 250V AC/ 20A 125V AC
 2. INSULATION RESISTANCE:>100M OHM 500VDC
 3. DIELECTRIC STRENGTH:2000V ONE MINUTE
C: APPROVALS:
 UL, CSA,VDE,SEV,SEMKO,FIMKO & NEMKO
D: OPTION GUIDE:

		Revision	
Rev.	Description	Date	Approved

PART NO.	ITEM	TERMINAL DIFFERENCE
745W-XX/PP	1+2	Solder Terminal 2.8X0.8 mm
745W-XX/QQ	1+3	Solder Terminal 4.0X0.8 mm
745W-XX/RR	1+4	Quick Con. Terminal 4.8X0.8mm
745W-XX/SS	1+5	Quick Con. Terminal 6.3X0.8mm

XX Panel Thickness (A) in 1/10 mm
 PP: 01,05,09,13,17 QQ:02,06,10,14,18
 RR: 03,07,11,15,19 QQ:04,08,12,16,20
 745W-15/05:Panel thickness 1.5mm terminal 2.8mm

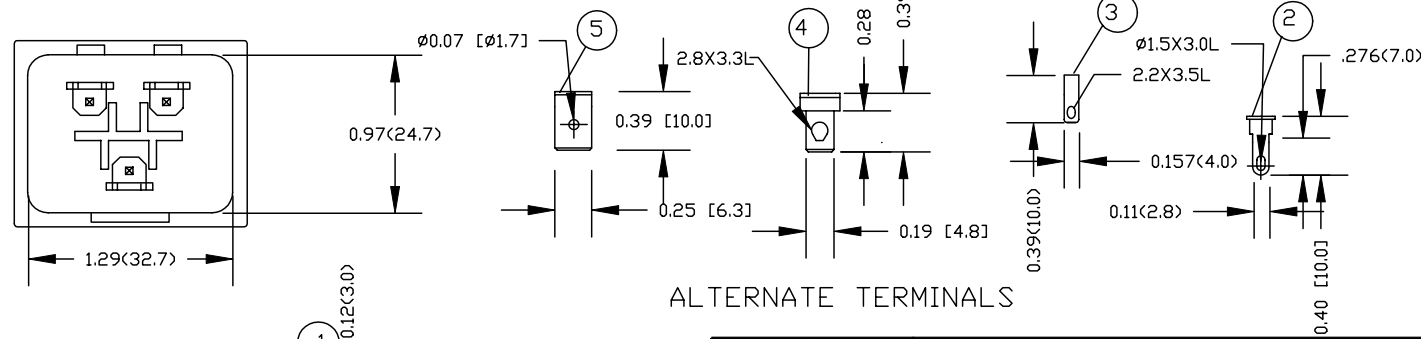
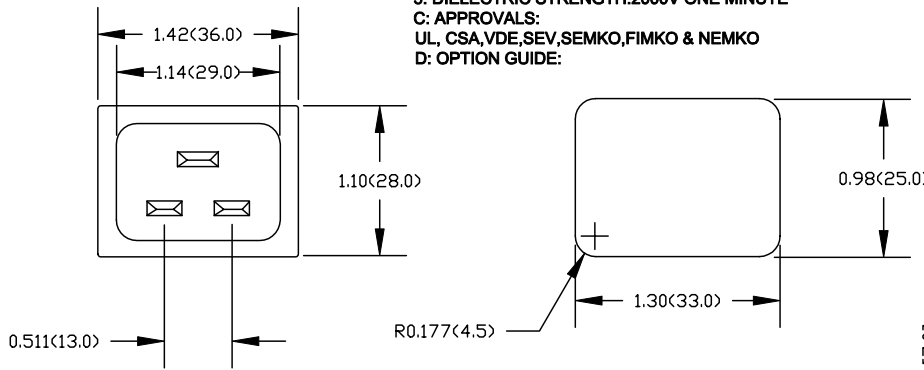

ALTERNATE TERMINALS

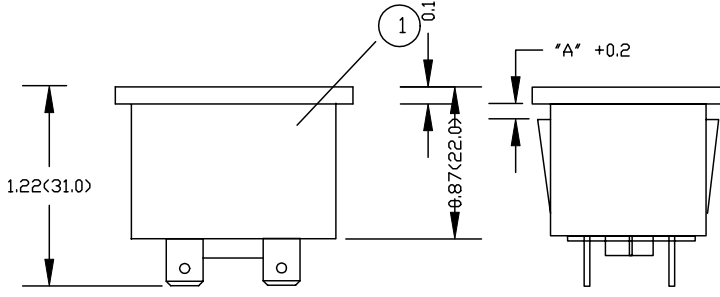

		Qualtek Electronics Corp. PPC DIVISION		
		Part Number: 745W SERIES		
		Description: AC RECEPTACLES		
Dim range (mm)	Tolerance +/- (mm)			
0-1	0.15			
1-6	0.20			
6-18	0.30			
18-50	0.50			
50-120	0.70	Drawn/Date	Checked/Date	Approved/Date
120-250	0.90	K.Huang	11-21-98	JJH/11-21-98
250-500	1.20	11-21-98		