

4

3

2

1

THIS DRAWING IS UNPUBLISHED. RELEASED FOR PUBLICATION  
 © COPYRIGHT BY TYCO ELECTRONICS CORPORATION. ALL RIGHTS RESERVED.

LOC	DIST	REVISIONS					
HM	00	F	LNK	DESCRIPTION	DATE	BY	APPD
		B		ADD: -5; NPR C97-105	18JUN97	GG	GB
		C		REV ECO-97-010901	18MAY97	LH	GB

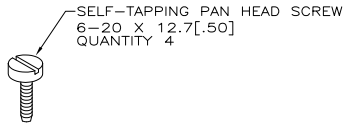

- 1 MATERIAL: ABS MOLDING COMPOUND, 94V-0 RATED, SEE TABLE FOR COLOR. SCREWS - ZINC PLATED CARBON STEEL.
- 2 ALL DIMENSIONS ARE MAXIMUM.
- 3 KIT SHIPPED NOT ASSEMBLED.
- 4 PACKAGED ONE KIT PER POLYBAG.

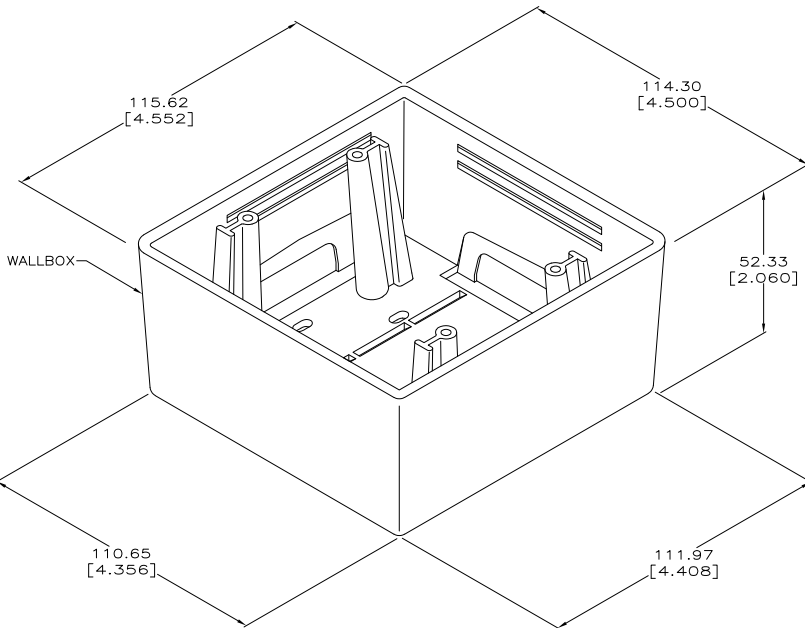

<b>SUPERSEDED BY I-569499-I</b>	ELECTRIC IVORY	1-569499-1
	ELECTRIC IVORY	569499-5
	NEMA GRAY	569499-4
	WHITE	569499-3
	BLACK	569499-2
	LT ALMOND	569499-1
	COLOR	PART NO.

THIS DRAWING IS A CONTROLLED DOCUMENT.		DR	DL	DBLUMMOND	8-22-95	Tyco Electronics Corporation Harrisburg, PA 17105-3608	
DIMENSIONS: mm [INCHES]		CHK	FOX		8-30-95	NAME	
TOLERANCES UNLESS OTHERWISE SPECIFIED:		APPRO		B. ANTHONY	8-30-95	WALLBOX KIT, SURFACE, DUAL GANG	
0 PLC ± .00		PRODUCT SPEC				SIZE	CAGE CODE
1 PLC ± .01		APPLICATION SPEC				A2	00779
2 PLC ± .02		WEIGHT				C	569499
3 PLC ± .03		RESTRICTED TO					
4 PLC ± .04		CUSTOMER DRAWING				SCALE	1:1
ANGLES ± .01						SHEET	1 of 1
FINISH						REV	C

AMP 1471-9 REV 31MMR2000

569499

A