

ISOMETRIC VIEW  
16 CIRCUIT MODULE

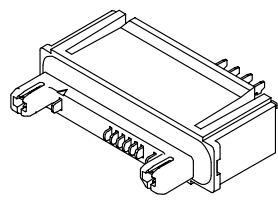

MODULE WITH VOIDED CIRCUITS  
(EXAMPLE)

- NOTES:
1. MATERIALS:  
HOUSING - THERMOPLASTIC, UL94V-0, COLOR:BLACK  
TERMINALS - COPPER ALLOY  
LATCHES - STAINLESS STEEL
  2. FINISHES: GOLD OVER NICKEL ON CONTACT AREAS,  
TIN OVER NICKEL ON SOLDER AREAS.
  3. PRODUCT SPECIFICATION: PS-44828-001  
APPLICATION SPECIFICATION: AS-44828-001
  4. PLEASE REFER TO MOLEX APPLICATION SPECIFICATION NO. AS-45339-001  
FOR RECOMMENDATIONS FOR OVERMOLDING AFTER CABLE ASSEMBLY.
  5. PACKAGED IN VACUUM-FORMED TRAYS (2100 PIECES PER CARTON).

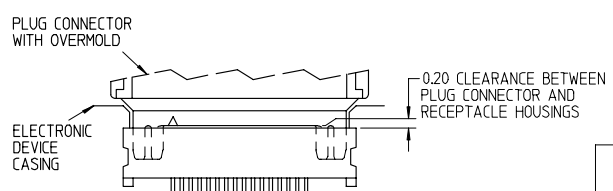

RECOMMENDATIONS FOR CONFIGURATION  
OF MATED CONNECTORS

IMPORTANT: PLEASE REFER TO MOLEX  
APPLICATION SPECIFICATION AS-44828-001 FOR  
DETAILED DESIGN LAYOUT AND MATING REQUIREMENTS

5				X	X	X	X										X	453391607
14	X	X	X	X	X	X	X		X	X	X	X	X	X	X	X	X	453391606
15	X	X	X	X	X	X	X	X	X	X	X	X	X	X	X	X	X	453391605
10	X	X	X	X	X	X	X	X	X		X	X						453391604
9	X								X	X	X	X	X	X	X	X	X	453391603
8	X								X	X	X	X	X	X	X	X	X	453391602
2	X																X	453391601
16	X	X	X	X	X	X	X	X	X	X	X	X	X	X	X	X	X	453391600
NO. OF CIRCUITS	1	2	3	4	5	6	7	8	9	10	11	12	13	14	15	16		MATERIAL NOS
	TERMINAL LOCATIONS (PRESENCE DENOTED BY AN X)																	

REVISED PER EC EC NO: UCP2006-1391 DRAWN:MSMMEL 2005/12/19 CHKD:MSMMEL 2005/12/20 APPR: JCOMERCI 2005/12/21 A	QUALITY SYMBOLS 0 0 DRAFT WHERE APPLICABLE MUST REMAIN WITHIN DIMENSIONS	GENERAL TOLERANCES (UNLESS SPECIFIED)		SCALE 3:1	DESIGN UNITS METRIC	THIRD ANGLE PROJECTION	REVISE ON CAD ONLY	
		mm	INCH	DIMENSION STYLE MM ONLY		TITLE		
		4 PLACES ±---	±---	DRAWN BY MSIMMEL	DATE 20051213	0.8MM HANDYLINK™ PLUG CONNECTOR MODULES FOR WIRE TERMINATION		
		3 PLACES ±---	±---	CHECKED BY MSIMMEL	DATE 20051213	MOLEX INCORPORATED		
2 PLACES ±0.10	±---	APPROVED BY COMERCI	DATE	MATERIAL NO. SEE CHART	DOCUMENT NO. SD-45339-001	SHEET NO. 1 OF 26		
1 PLACE ±0.13	±---	THIS DRAWING CONTAINS INFORMATION THAT IS PROPRIETARY TO MOLEX INCORPORATED AND SHOULD NOT BE USED WITHOUT WRITTEN PERMISSION						



# HANDYLINK™ APPLICATION SPECIFICATION

## HANDYLINK™ I/O CONNECTORS

44828 SMT Receptacle  
Connector

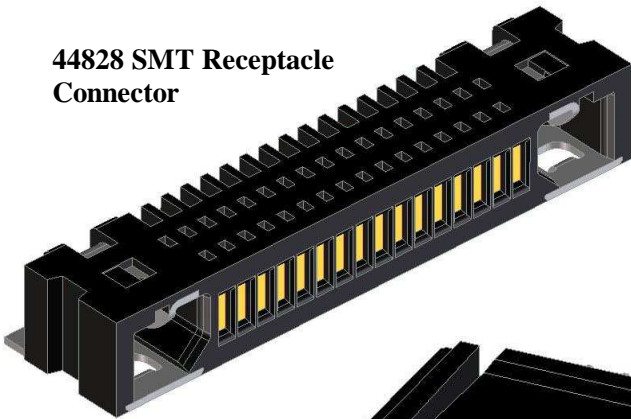

45560 SMT Cradle  
Connector

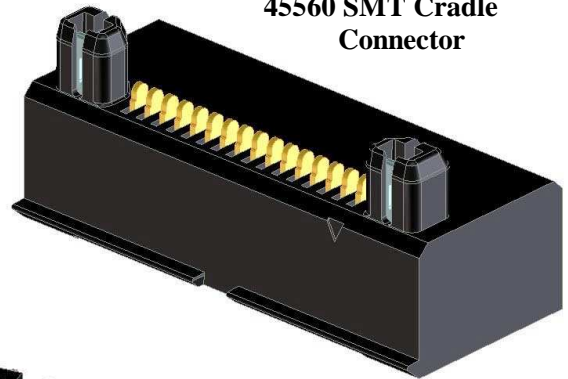

45339 and 45593  
Plug Connector Modules

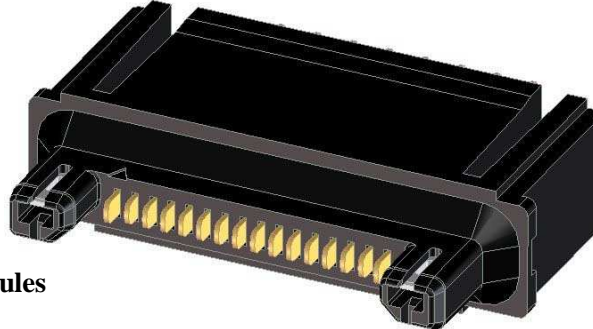

REVISION: <b>A</b>	ECR/ECN INFORMATION: EC No: UCP2006- 1391 DATE: 2005/12/13	TITLE: <b>APPLICATION SPECIFICATION HANDYLINK™/I/O CONNECTOR SYSTEM</b>	SHEET No. 2 of 26
DOCUMENT NUMBER: <b>SD-45339-001</b>	CREATED / REVISED BY: <b>M. Simmel</b>	CHECKED BY: <b>Marc Simmel</b>	APPROVED BY: <b>Joe Comerchi</b>

TEMPLATE FILENAME: PRODUCT\_SPEC[SIZE\_A](V.1).DOC



# HANDYLINK™ APPLICATION SPECIFICATION

		<u>Table of Contents</u>			
<u>Section</u>		<u>Page</u>	<u>Section</u>		<u>Page</u>
1.0	Scope	3	6.0	Mechanical Design Recommendations	
2.0	Product Description	3	6.1	Mechanical Fasteners and Support	8
3.0	Applicable Documents and Specifications	3	6.1.1	Receptacle Connector	
4.0	Mating and Un-Mating of Connectors		6.1.2	Plug Connector Modules	
4.1	Recommendations for Mating and Un-Mating	4	6.1.3	Cradle Connector	
4.2	Mating Alignment Tolerances	4	6.2	Ingress Protection	10
5.0	Soldering Process Recommendations		6.3	Plug Cable Over-Molding	11
5.1	44828 SMT Receptacle Connector	6	6.3.1	Wire Soldering	
5.1.1	PCB Layout		6.3.2	Encapsulation	
5.1.2	Solder Paste Stencil Layout		6.3.3	Strain Relief	
5.1.3	Reflow Profile		6.3.4	Final Over-Molding	
5.1.4	Inspection		6.4	Design Best Practices	14
5.2	45560 SMT Cradle Connector	6	6.4.1	Plug Over-mold Designs	
5.2.1	PCB Layout		6.4.2	Cradle Designs	
5.2.2	Solder Paste Stencil Layout		7.0	Electrical Recommendations	
5.2.3	Reflow Profile		7.1	Power Considerations	21
5.2.4	Inspection		7.2	High Speed Signal Transmission	21
5.3	45339 Plug Module for Wire Termination	7			
5.3.1	Applicable Wire Sizes				
5.3.2	Wire Preparation				
5.3.3	Inspection				
5.4	45593 Plug Module for PCB Termination	7			
5.4.1	PCB Layout				
5.4.2	Inspection				

<u>REVISION:</u> <b>A</b>	<u>ECR/ECN INFORMATION:</u> EC No: <b>UCP2006- 1391</b> DATE: <b>2005/12/13</b>	<u>TITLE:</u> <b>APPLICATION SPECIFICATION HANDYLINK™/I/O CONNECTOR SYSTEM</b>	<u>SHEET No.</u> 3 of 26
<u>DOCUMENT NUMBER:</u> <b>SD-45339-001</b>	<u>CREATED / REVISED BY:</u> <b>M. Simmel</b>	<u>CHECKED BY:</u> <b>Marc Simmel</b>	<u>APPROVED BY:</u> <b>Joe Comerchi</b>

TEMPLATE FILENAME: PRODUCT\_SPEC[SIZE\_A](V.1).DOC



# HANDYLINK™ APPLICATION SPECIFICATION

## 1.0 SCOPE

This specification addresses the manufacturing techniques and end-usage considerations for Molex's 0.8mm pitch HandyLink™ I/O Connectors. The common contact interface used in this family of connectors consists of a flat pad mated to a radiussed edge on a compression spring blade. The flat pad is enclosed by plastic in an over-molded receptacle housing which provides a sealed interface to facilitate ingress protection. The compression spring blades are extremely durable and are capable of sustaining over 20,000 mating cycles. Two "passive" latches counteract the compression springs to keep the connector pairs mated but enable simple disconnection by the end-user.

The customer is encouraged to contact Molex with any questions regarding the application of this product.

## 2.0 PRODUCT DESCRIPTION

### 2.1 Product Names and Part Numbers

#### SMT Receptacle Connectors

Series: 44828

#### SMT Cradle Connectors

Series 45560 (Perpendicular and Parallel Mating)

#### Plug Connector Modules

Series 45339 (Wire Termination)

Series 45593 (PCB Termination)

### 2.2 Dimensions, Materials, Platings, and Markings

(See applicable sales drawings for information)

## 3.0 APPLICABLE DOCUMENTS AND SPECIFICATIONS

Product Specification: PS-44828-001; Sales Drawings: SD-44828-162, SD-45560-160, SD-45560-161, SD-45339-160, SD-45593-160

<u>REVISION:</u> <b>A</b>	<u>ECR/ECN INFORMATION:</u> EC No: <b>UCP2006- 1391</b> DATE: <b>2005/12/13</b>	<u>TITLE:</u> <b>APPLICATION SPECIFICATION HANDYLINK™ I/O CONNECTOR SYSTEM</b>	<u>SHEET No.</u> 4 of 26
<u>DOCUMENT NUMBER:</u> <b>SD-45339-001</b>		<u>CREATED / REVISED BY:</u> <b>M. Simmel</b>	<u>CHECKED BY:</u> <b>Marc Simmel</b>
		<u>APPROVED BY:</u> <b>Joe Comerchi</b>	

TEMPLATE FILENAME: PRODUCT\_SPEC[SIZE\_A](V.1).DOC



# HANDYLINK™ APPLICATION SPECIFICATION

## 4.0 MATING AND UN-MATING OF CONNECTORS

This section describes the preferred methods for mating and un-mating the HandyLink™ connectors.

### 4.1 Recommendations for Mating and Un-Mating

This connector system utilizes a “passive” latching feature. There is no button to press to latch or unlatch. To latch, simply push the plug into the receptacle (the connectors are polarized to discourage improper mating). To unlatch, simply grip the plug body firmly and pull it straight out of the receptacle.

### 4.2 Mating Alignment Tolerances

#### 4.2.a 44828 Receptacle to 45339 or 45593 Plug Connectors

The HandyLink™ plug and receptacle have been appropriately designed and tolerated to be mated and unmated by hand. The connectors' alignment features are manufactured with clearances to allow axial mating mis-alignment, as illustrated in the Figure 1, below:

**Figure 1.** Receptacle to Plug Connector  
Axial Alignment (units: mm)

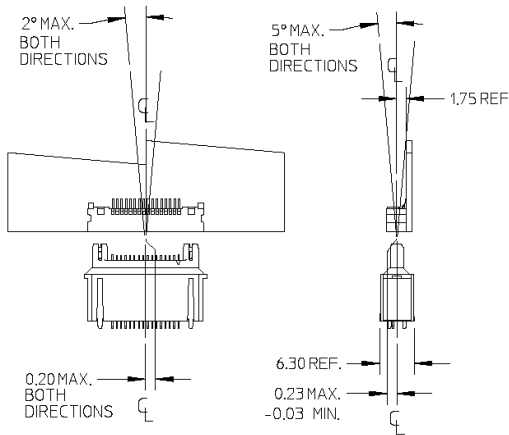

REVISION: <b>A</b>	ECR/ECN INFORMATION: EC No: <b>UCP2006- 1391</b> DATE: <b>2005/12/13</b>	TITLE: <b>APPLICATION SPECIFICATION HANDYLINK™/I/O CONNECTOR SYSTEM</b>	SHEET No. 5 of 26
DOCUMENT NUMBER: <b>SD-45339-001</b>	CREATED / REVISED BY: <b>M. Simmel</b>	CHECKED BY: <b>Marc Simmel</b>	APPROVED BY: <b>Joe Comerci</b>

TEMPLATE FILENAME: PRODUCT\_SPEC[SIZE\_A](V.1).DOC



# HANDYLINK™ APPLICATION SPECIFICATION

## 4.2 Mating Alignment Tolerances (continued)

### 4.2.b 44828 Receptacle to 45560 Cradle Connectors

The HandyLink™ receptacle and cradle connectors' alignment features are manufactured with clearances to allow some axial mating mis-alignment as illustrated in the Figure 2, below:

Figure 2. Receptacle to Cradle Connector Axial Alignment (units: mm)

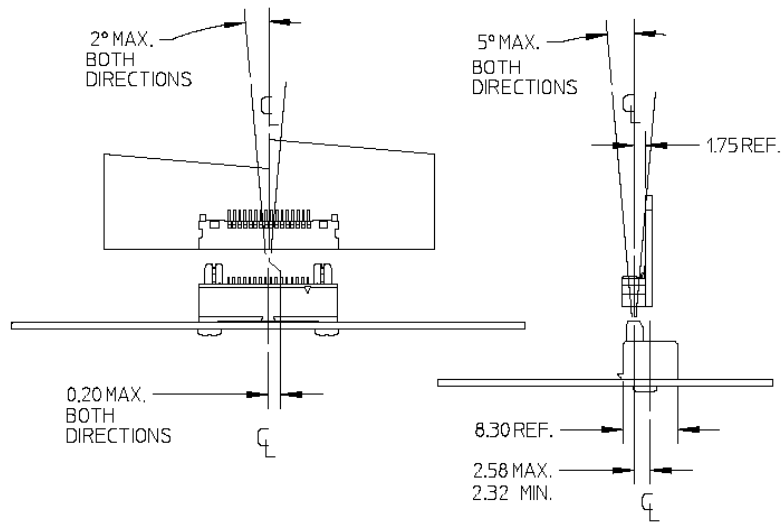

NOTE: Mating misalignment may significantly influence the long-term durability of the connectors. The risk of housing wear diminishes with increasing the accuracy of connector alignment.

<b>REVISION:</b>  <b>A</b>	<b>ECR/ECN INFORMATION:</b> EC No: <b>UCP2006- 1391</b> DATE: <b>2005/12/13</b>	<b>TITLE:</b>  <b>APPLICATION SPECIFICATION HANDYLINK™/I/O CONNECTOR SYSTEM</b>		<b>SHEET No.</b>  6 of 26
<b>DOCUMENT NUMBER:</b>  <b>SD-45339-001</b>		<b>CREATED / REVISED BY:</b>  <b>M. Simmel</b>	<b>CHECKED BY:</b>  <b>Marc Simmel</b>	<b>APPROVED BY:</b>  <b>Joe Comerchi</b>

TEMPLATE FILENAME: PRODUCT\_SPEC[SIZE\_A](V.1).DOC



# HANDYLINK™ APPLICATION SPECIFICATION

### 4.3 Clearances Between Mated Parts

The HandyLink connectors are designed such that the corresponding 'front' faces fully engage and then spring back 0.20mm to the final mated condition. This 'over-travel clearance' assures that the components of the passive latching system engage. Please see Section 6.4 Design Best Practices for further detailed information.

## 5.0 SOLDERING PROCESS RECOMMENDATIONS

### 5.1 44828 SMT Receptacle Connector

#### 5.1.1 PCB Layout

See the applicable Sales Drawing for an illustration of the recommended PCB layout. Contact Molex if further assistance is required.

#### 5.1.2 Solder Paste Stencil Layout

See Sales Drawing for solderable surfaces. Contact Molex if further assistance is required.

#### 5.1.3 Reflow Profile

While the production solder reflow profile is typically established by the customer, based on their specific application, generic reflow profiles can be found in Product Specification PS-44828-001. The profiles are provided for reference purposes only.

#### 5.1.4 Inspection

Solder joints should be inspected using established conventional methods.

### 5.2 45560 SMT Cradle Connector

#### 5.2.1 PCB Layout

See the applicable Sales Drawings for illustrations of the recommended PCB pad layouts. Contact Molex if further assistance is required.

#### 5.2.2 Solder Paste Stencil Layout

See Sales Drawing for recommended PCB pad layout and solder paste thickness.

<u>REVISION:</u> <b>A</b>	<u>ECR/ECN INFORMATION:</u> EC No: <b>UCP2006- 1391</b> DATE: <b>2005/12/13</b>	<u>TITLE:</u> <b>APPLICATION SPECIFICATION HANDYLINK™/I/O CONNECTOR SYSTEM</b>	<u>SHEET No.</u> 7 of 26
<u>DOCUMENT NUMBER:</u> <b>SD-45339-001</b>		<u>CREATED / REVISED BY:</u> <b>M. Simmel</b>	<u>CHECKED BY:</u> <b>Marc Simmel</b>
		<u>APPROVED BY:</u> <b>Joe Comerchi</b>	

TEMPLATE FILENAME: PRODUCT\_SPEC[SIZE\_A](V.1).DOC



# HANDYLINK™ APPLICATION SPECIFICATION

## 5.2.3 Reflow Profile

While the production solder reflow profile is typically established by the customer, based on their specific application, generic reflow profiles can be found in Product Specification PS-44828-001. The profiles are provided for reference purposes only.

## 5.2.4 Inspection

Solder joints should be inspected using established conventional methods.

## 5.3 45339 Plug Module for Wire Termination

### 5.3.1 Applicable Wire Sizes

Copper conductor size: 22 to 34 AWG (stranded wires are recommended for flexibility) may be used, however, 22 to 28 AWG conductors are necessary to transmit 1.5 Amperes DC continuously.

Maximum insulation diameter: 1.6mm

NOTE: Small conductor sizes are suitable for the transmission of digital signals, and may improve wire bundle flexibility and harness workability.

### 5.3.2 Wire Preparation

Strip length: 2.0 ~ 2.5mm

Pre-tinning is recommended.

### 5.3.3 Inspection

Solder joints should be inspected using established conventional methods.

## 5.4 45593 Plug Module for PCB Termination

### 5.4.1 PCB Layout

See the applicable Sales Drawing for an illustration of the recommended PCB hole layout.

### 5.4.2 Inspection

Solder joints should be inspected using established conventional methods.

REVISION: <b>A</b>	ECR/ECN INFORMATION: EC No: <b>UCP2006- 1391</b> DATE: <b>2005/12/13</b>	TITLE: <b>APPLICATION SPECIFICATION HANDYLINK™/I/O CONNECTOR SYSTEM</b>	SHEET No. 8 of 26
DOCUMENT NUMBER: <b>SD-45339-001</b>	CREATED / REVISED BY: <b>M. Simmel</b>	CHECKED BY: <b>Marc Simmel</b>	APPROVED BY: <b>Joe Comerchi</b>

TEMPLATE FILENAME: PRODUCT\_SPEC[SIZE\_A](V.1).DOC





# HANDYLINK™ APPLICATION SPECIFICATION

## 6.0 MECHANICAL MOUNTING RECOMMENDATIONS

### 6.1 Mechanical Fasteners and Support

#### 6.1.1 Receptacle Connector

Molex recommends that the receptacle connector be mounted within the end-application enclosure such that it is recessed by 1.6 to 2.4mm from the outermost faces and with a 0.10mm maximum clearance with the casing inner walls. Such a recess provides multiple advantages in terms of protecting the contact surfaces from accidental impact with foreign objects, providing mechanical support when the mating plug connector assembly is torqued by abusive handling, and helps to reduce direct contact with hand oils or other contamination. See Figures 3A and 3B, below, for recommendations on recess dimensions.

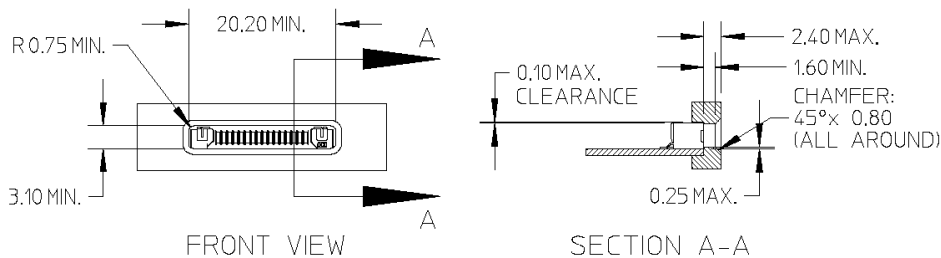

Figure 3A. Receptacle Connector Recess When Mating with the Plug Only (units: mm)

REVISION: <b>A</b>	ECR/ECN INFORMATION: EC No: UCP2006- 1391 DATE: 2005/12/13	TITLE: <b>APPLICATION SPECIFICATION HANDYLINK™/I/O CONNECTOR SYSTEM</b>	SHEET No. 9 of 26
DOCUMENT NUMBER: <b>SD-45339-001</b>	CREATED / REVISED BY: <b>M. Simmel</b>	CHECKED BY: <b>Marc Simmel</b>	APPROVED BY: <b>Joe Comerchi</b>

TEMPLATE FILENAME: PRODUCT\_SPEC[SIZE\_A](V.1).DOC



# HANDYLINK™ APPLICATION SPECIFICATION

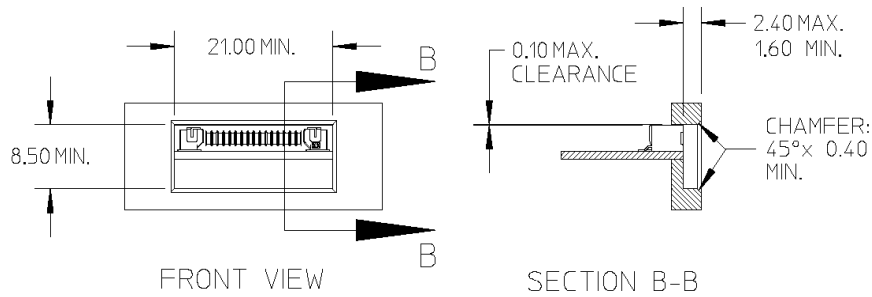

**Figure 3B.** Receptacle Connector Recess When Mating with the Plug or Cradle Connectors (units: mm)

Wherever possible, the 0.10 maximum clearance condition with the receptacle should be minimized by utilizing a clam-shell style package design.

### 6.1.2 Plug Connector Module

The plug connector module is intended to be used as a part of an assembly using either direct wire soldering (**45339**) or using an intermediary PCB (**45593**). Overmolding and/or clam shell style covers must be used to protect the wire connections and the appropriate service loops and wire strain reliefs must be incorporated in a cable assembly to prevent damage during use. Please refer to section 6.3 for further details about the over-molding process.

If the connector module is used as a stand-alone component on a PCB, the mating interface must be adequately supported. Please refer to section 6.4.2 for further details concerning cradle design recommendations.

### 6.1.3 Cradle Connector

The cradle connector is designed to be fastened to the PCB with screws. See Sales Drawings for recommended screw size and positions. Please refer to section 6.4.2 for further details concerning cradle design recommendations.

<u>REVISION:</u> <b>A</b>	<u>ECR/ECN INFORMATION:</u> EC No: <b>UCP2006- 1391</b> DATE: <b>2005/12/13</b>	<u>TITLE:</u> <b>APPLICATION SPECIFICATION HANDYLINK™/I/O CONNECTOR SYSTEM</b>	<u>SHEET No.</u> 10 of 26
<u>DOCUMENT NUMBER:</u> <b>SD-45339-001</b>		<u>CREATED / REVISED BY:</u> <b>M. Simmel</b>	<u>CHECKED BY:</u> <b>Marc Simmel</b>
		<u>APPROVED BY:</u> <b>Joe Comerchi</b>	

TEMPLATE FILENAME: PRODUCT\_SPEC[SIZE\_A](V.1).DOC



# HANDYLINK™ APPLICATION SPECIFICATION

## 6.2 Ingress Protection

Ingress protection, as described by IEC 60529, is a function of the customer's enclosure. The HandyLink™ Receptacle Connector has been designed to facilitate enclosure design when ingress protection is required. The interfaces between the metal and plastic components of the connector are sealed to discourage intrusion of dust and liquid through the connector into the enclosure. The customer is expected to design an appropriate seal around the periphery of the connector to adequately seal the finished enclosure. Contact Molex for additional information.

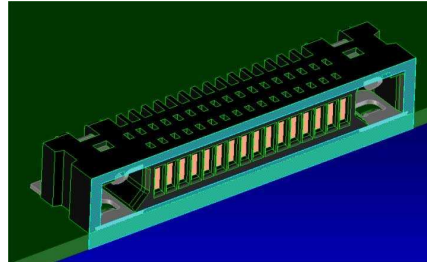
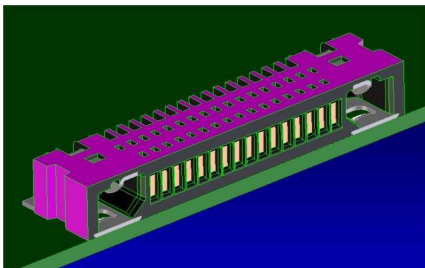

Gaskets may be applied to the top and sides, or front surfaces.

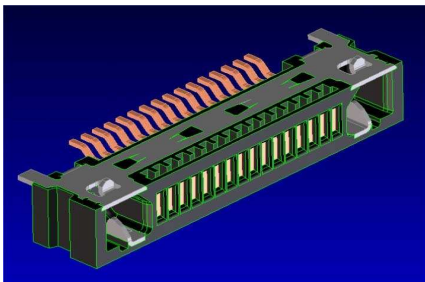

The bottom surface, once soldered, forms a continuous seal with the PCB

Figure 4. Sealing to achieve ingress protection with the receptacle connector

<u>REVISION:</u> <b>A</b>	<u>ECR/ECN INFORMATION:</u> EC No: <b>UCP2006- 1391</b> DATE: <b>2005/12/13</b>	<u>TITLE:</u> <b>APPLICATION SPECIFICATION HANDYLINK™/I/O CONNECTOR SYSTEM</b>	<u>SHEET No.</u> 11 of 26
<u>DOCUMENT NUMBER:</u> <b>SD-45339-001</b>		<u>CREATED / REVISED BY:</u> <b>M. Simmel</b>	<u>CHECKED BY:</u> <b>Marc Simmel</b>
		<u>APPROVED BY:</u> <b>Joe Comerci</b>	

TEMPLATE FILENAME: PRODUCT\_SPEC[SIZE\_A](V.1).DOC



# HANDYLINK™ APPLICATION SPECIFICATION

## 6.3 Plug Cable Over-Molding

### 6.3.1 Wire Soldering

This section provides an outline of the recommended plug cable over-molding practices for the 45339 and 45593 plug connector modules. The 45339 connector (a 16-circuit wire termination version) is shown, below, prior to soldering. Please note the following features:

Latch soldertails (2 places)                      Wire soldertails (2 rows)

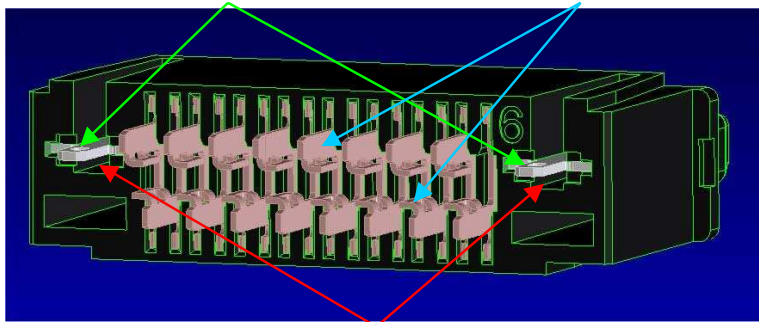

Cavities under the latches (2 places)

Figure 5. Solder tail side of the plug connector

Pre-tinned wires should be terminated to the appropriate solder tails working in sequence and one row at a time, taking care that the insulation does not become exposed more than 1mm from the end of the terminals. The completed assembly after soldering of the wires is shown below. Dressing of the wires should be avoided until after the soldering and encapsulation processes are complete.

REVISION: <b>A</b>	ECR/ECN INFORMATION: EC No: UCP2006- 1391 DATE: 2005/12/13	TITLE: <b>APPLICATION SPECIFICATION HANDYLINK™/I/O CONNECTOR SYSTEM</b>	SHEET No. 12 of 26
DOCUMENT NUMBER: <b>SD-45339-001</b>	CREATED / REVISED BY: <b>M. Simmel</b>	CHECKED BY: <b>Marc Simmel</b>	APPROVED BY: <b>Joe Comerchi</b>

TEMPLATE FILENAME: PRODUCT\_SPEC[SIZE\_A](V.1).DOC



# HANDYLINK™ APPLICATION SPECIFICATION

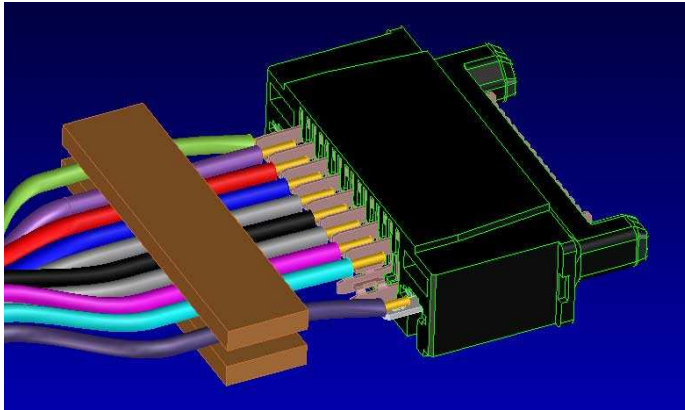

Figure 6.  
Plug Soldering Set-Up

NOTE: The wire bundle must be properly supported or clamped as shown, during soldering and handling, to avoid dislodging terminals or latches from the housing prior to encapsulation, application of a strain relief, and the final over-mold.

REVISION: <b>A</b>	ECR/ECN INFORMATION: EC No: <b>UCP2006- 1391</b> DATE: <b>2005/12/13</b>	TITLE: <b>APPLICATION SPECIFICATION HANDYLINK™/I/O CONNECTOR SYSTEM</b>	SHEET No. 13 of 26
DOCUMENT NUMBER: <b>SD-45339-001</b>	CREATED / REVISED BY: <b>M. Simmel</b>	CHECKED BY: <b>Marc Simmel</b>	APPROVED BY: <b>Joe Comerchi</b>

TEMPLATE FILENAME: PRODUCT\_SPEC[SIZE\_A](V.1).DOC



# HANDYLINK™ APPLICATION SPECIFICATION

## 6.3.2 Encapsulation

The next step after soldering is to pre-seal or encapsulate the back end of the connector and hold the wires in place using a silicone sealant or a low-pressure Macro-melt polyamide adhesive molding. The sealant will prevent accidental shorting between adjacent terminals and discourage intrusion of over-mold resin into the terminal and latch cavities. An illustration of the pre-seal coverage is shown below. Care must be taken to ensure that no encapsulant enters the terminal or latch cavities.

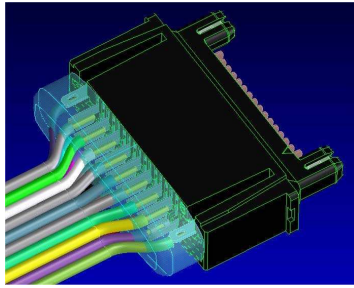

Figure 7.  
Encapsulated plug connector

An alternate method is to combine one or more molded 'covers' to block entire sections where void circuits are present, then use a pre-seal or encapsulant to hold the wires separate. This is illustrated below.

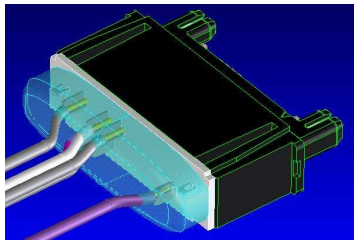

Figure 8.  
Covered and encapsulated plug connector

NOTE: The sealant or cover should enclose the cavities under the latches, whether or not wires are soldered to the latches. Omission of this step would allow the final over-mold resin to extrude into cavities in the housing that could disable latch and terminal function.

<u>REVISION:</u>  <b>A</b>	<u>ECR/ECN INFORMATION:</u> EC No: <b>UCP2006- 1391</b> DATE: <b>2005/12/13</b>	<u>TITLE:</u>  <b>APPLICATION SPECIFICATION HANDYLINK™/I/O CONNECTOR SYSTEM</b>		<u>SHEET No.</u>  14 of 26
<u>DOCUMENT NUMBER:</u>  <b>SD-45339-001</b>		<u>CREATED / REVISED BY:</u>  <b>M. Simmel</b>	<u>CHECKED BY:</u>  <b>Marc Simmel</b>	<u>APPROVED BY:</u>  <b>Joe Comerchi</b>

TEMPLATE FILENAME: PRODUCT\_SPEC[SIZE\_A](V.1).DOC



# HANDYLINK™ APPLICATION SPECIFICATION

### 6.3.3 Strain Relief

Molex strongly recommends the use of a crimp barrel or ferrule over the wire bundle (including ground or drain wire) that also captures the cable jacket and tension member, if used. This will uniformly distribute mechanical loads through the wire bundle and provide mechanical support to the cable jacket and tension member.

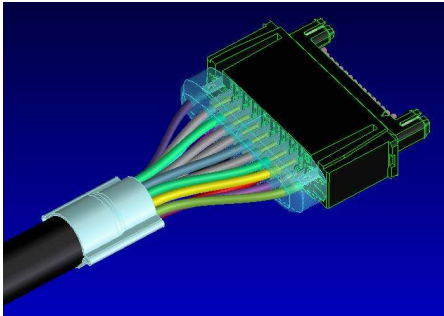

Figure 9.  
Crimp barrel installed

### 6.3.4 Final Over-Molding

The final PVC over-mold may be injection-molded to completely cover the prepared cable assembly to provide an esthetically pleasing finished product. Please see Section 6.4.1 for a discussion of design best practices for the over-mold.

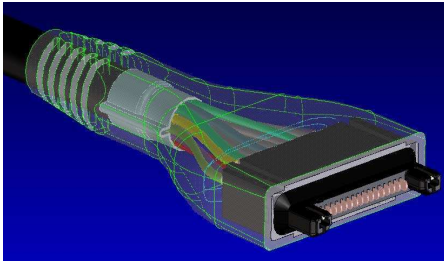

Figure 10.  
Finished over-mold (shown transparent)

<u>REVISION:</u> <b>A</b>	<u>ECR/ECN INFORMATION:</u> EC No: <b>UCP2006- 1391</b> DATE: <b>2005/12/13</b>	<u>TITLE:</u> <b>APPLICATION SPECIFICATION HANDYLINK™/I/O CONNECTOR SYSTEM</b>		<u>SHEET No.</u> 15 of 26
<u>DOCUMENT NUMBER:</u> <b>SD-45339-001</b>		<u>CREATED / REVISED BY:</u> <b>M. Simmel</b>	<u>CHECKED BY:</u> <b>Marc Simmel</b>	<u>APPROVED BY:</u> <b>Joe Comerchi</b>

TEMPLATE FILENAME: PRODUCT\_SPEC[SIZE\_A](V.1).DOC



# HANDYLINK™ APPLICATION SPECIFICATION

## 6.4 Design Best Practices

The information provided so far in this document has been related to the basic usage conditions of the HandyLink™ connectors. The sections that follow contain important information and guidelines for design that apply to specific applications or industrial design constraints for the end-product accessories. In all cases, Molex advises that prototype assemblies be used as early in the design and development cycle as possible to simulate and assess true usage conditions in the actual end-products. Please contact Molex for technical assistance with design feasibility studies or design reviews.

### 6.4.0 Mating Over-Travel Clearance

The HandyLink connectors are designed such that the corresponding 'front' faces fully engage and then spring back 0.20mm to the final mated condition. This 'over-travel clearance' assures that the components of the passive latching system engage, as illustrated in Figure 11. This clearance must be accommodated in all device and accessory designs to assure proper function.

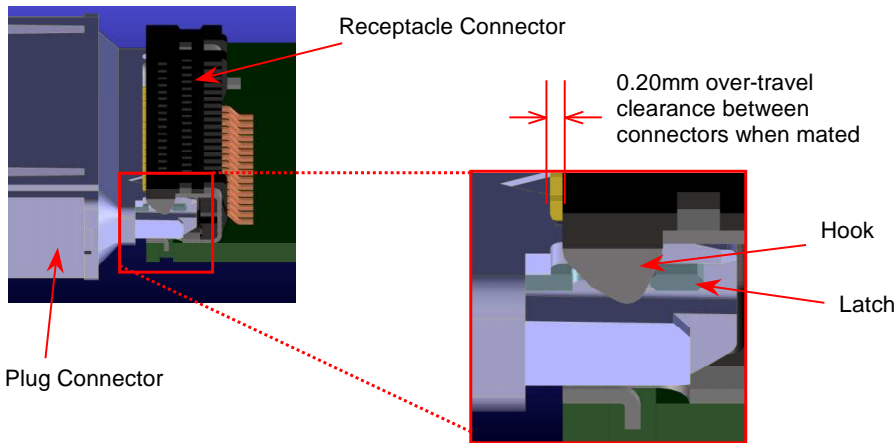

REVISION: <b>A</b>	ECR/ECN INFORMATION: EC No: UCP2006- 1391 DATE: 2005/12/13	TITLE: <b>APPLICATION SPECIFICATION HANDYLINK™/I/O CONNECTOR SYSTEM</b>	SHEET No. 16 of 26
DOCUMENT NUMBER: <b>SD-45339-001</b>	CREATED / REVISED BY: <b>M. Simmel</b>	CHECKED BY: <b>Marc Simmel</b>	APPROVED BY: <b>Joe Comerchi</b>

TEMPLATE FILENAME: PRODUCT\_SPEC[SIZE\_A](V.1).DOC





# HANDYLINK™ APPLICATION SPECIFICATION

## 6.4.1 Plug Over-Mold Designs

Supplemental guide features to align the connectors during mating or un-mating are strongly recommended if any of the following conditions are present:

- A great deal of curvature in the end product (such as that illustrated, below);
- The accessory cable is stiff or bent abruptly;
- The mass of the end-product itself is greater than 1000grams and is likely to experience more than 1g of acceleration during use or under vibration;
- The cable connection and disconnection cycles are numerous (more than 5000 cycles);
- There is significant risk of the end users pulling at connections in off-axis directions.

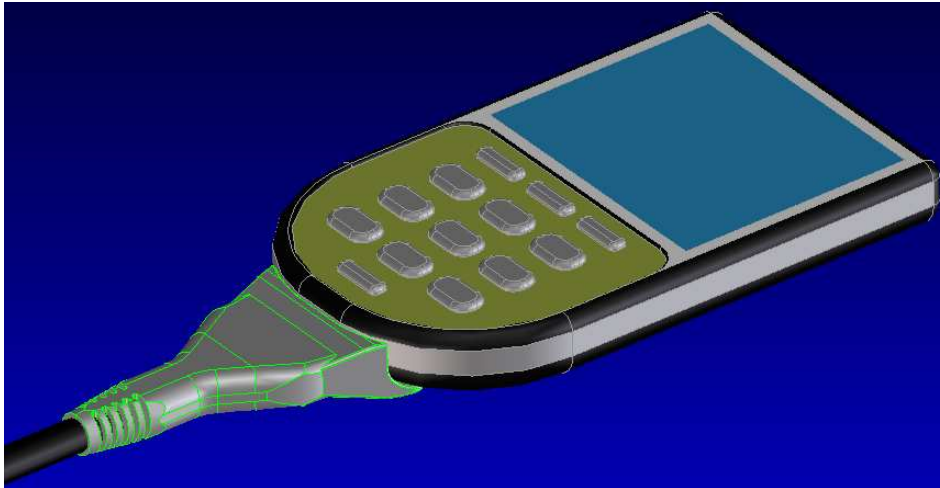

Figure 12. Example of an application with a great degree of curvature near the connector interface.

Supplemental guide features may be incorporated into or complement the over-mold design as illustrated in Figures 12 and 13:

<b>REVISION:</b>  <b>A</b>	<b>ECR/ECN INFORMATION:</b> EC No: <b>UCP2006- 1391</b> DATE: <b>2005/12/13</b>	<b>TITLE:</b> <b>APPLICATION SPECIFICATION HANDYLINK™/I/O CONNECTOR SYSTEM</b>		<b>SHEET No.</b> 17 of 26
<b>DOCUMENT NUMBER:</b> <b>SD-45339-001</b>		<b>CREATED / REVISED BY:</b> <b>M. Simmel</b>	<b>CHECKED BY:</b> <b>Marc Simmel</b>	<b>APPROVED BY:</b> <b>Joe Comerchi</b>

TEMPLATE FILENAME: PRODUCT\_SPEC[SIZE\_A](V.1).DOC



# HANDYLINK™ APPLICATION SPECIFICATION

○ **Contouring with a Lip**

To provide mechanical support for torque out of the axial plane of the connectors, the over-mold must be designed to mimic the outer surfaces of the end product and include a lip such as illustrated below. NOTE: The axial clearance condition between the connectors noted in section 4.2 must be maintained.

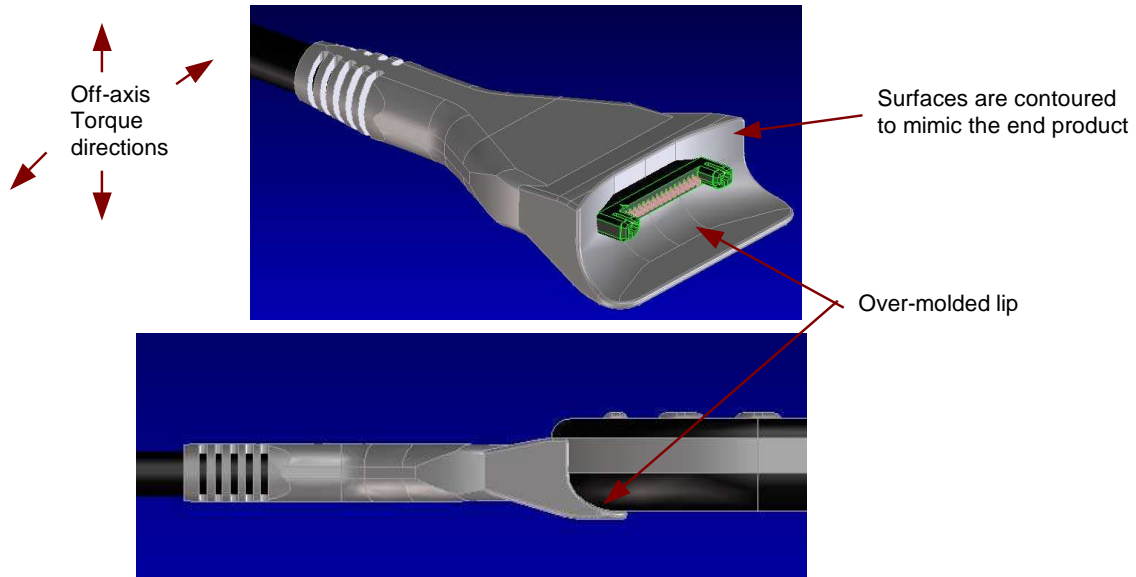

Figure 13. Example of an over-mold with contouring and a lip

This type of design will provide support for the end-user to hold the product by the connector or where a heavy or stiff accessory cable is used.

<u>REVISION:</u> <b>A</b>	<u>ECR/ECN INFORMATION:</u> EC No: <b>UCP2006- 1391</b> DATE: <b>2005/12/13</b>	<u>TITLE:</u> <b>APPLICATION SPECIFICATION HANDYLINK™/I/O CONNECTOR SYSTEM</b>	<u>SHEET No.</u> 18 of 26
<u>DOCUMENT NUMBER:</u> <b>SD-45339-001</b>		<u>CREATED / REVISED BY:</u> <b>M. Simmel</b>	<u>CHECKED BY:</u> <b>Marc Simmel</b>
		<u>APPROVED BY:</u> <b>Joe Comerci</b>	
TEMPLATE FILENAME: PRODUCT_SPEC[SIZE_A](V.1).DOC			



# HANDYLINK™ APPLICATION SPECIFICATION

○ **Supplemental Latching and Alignment Posts**

Where the mass of the end product is greater than 1000 grams and is subject to sudden accelerations or strong vibrations during use, a cup-style receptacle needs to be considered to adequately protect the connection interface. The cup-style receptacle should incorporate separate external latching features and supplemental alignment posts similar to those illustrated below. NOTE: The cup-style receptacle's dimensions must restrict angular misalignment, when mated, to within the limits specified in Section 4.2.

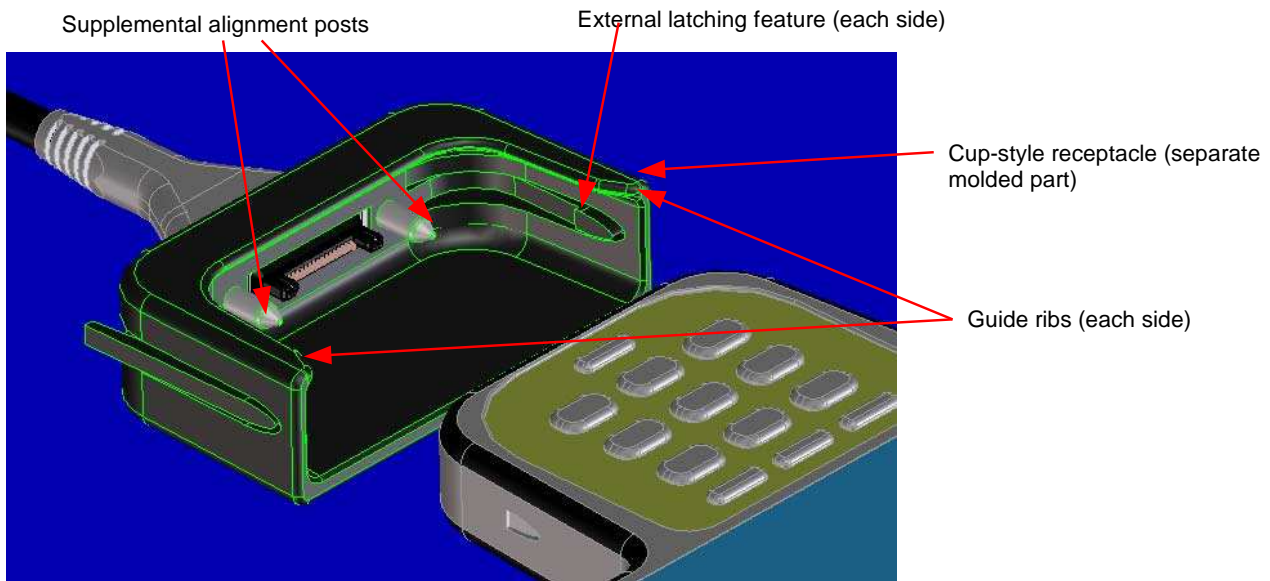

Figure 14. Use of a cup-style receptacle for added support and alignment

<u>REVISION:</u> <b>A</b>	<u>ECR/ECN INFORMATION:</u> EC No: <b>UCP2006- 1391</b> DATE: <b>2005/12/13</b>	<u>TITLE:</u> <b>APPLICATION SPECIFICATION HANDYLINK™/I/O CONNECTOR SYSTEM</b>	<u>SHEET No.</u> 19 of 26
<u>DOCUMENT NUMBER:</u> <b>SD-45339-001</b>	<u>CREATED / REVISED BY:</u> <b>M. Simmel</b>	<u>CHECKED BY:</u> <b>Marc Simmel</b>	<u>APPROVED BY:</u> <b>Joe Comerchi</b>

TEMPLATE FILENAME: PRODUCT\_SPEC[SIZE\_A](V.1).DOC



# HANDYLINK™ APPLICATION SPECIFICATION

Supplemental alignment posts must be longer than the protrusion of the plug connector posts from the base surface of the cup-style receptacle. Further, the alignment posts' centerlines must lie in the same plane as the centerlines of the plug connector posts to provide the greatest benefits. Guide ribs are necessary to prevent front-to back rocking motion as the device is loaded into the cup-style receptacle.

NOTE: The fastening of the cup-style receptacle to the over-molded plug must be kept tight to avoid misalignment. If this is not achieved, excessive wear between the connector housings and/or electrical discontinuities may occur.

<u>REVISION:</u> <b>A</b>	<u>ECR/ECN INFORMATION:</u> EC No: <b>UCP2006- 1391</b> DATE: <b>2005/12/13</b>	<u>TITLE:</u> <b>APPLICATION SPECIFICATION HANDYLINK™/I/O CONNECTOR SYSTEM</b>	<u>SHEET No.</u> 20 of 26
<u>DOCUMENT NUMBER:</u> <b>SD-45339-001</b>	<u>CREATED / REVISED BY:</u> <b>M. Simmel</b>	<u>CHECKED BY:</u> <b>Marc Simmel</b>	<u>APPROVED BY:</u> <b>Joe Comerchi</b>

TEMPLATE FILENAME: PRODUCT\_SPEC[SIZE\_A](V.1).DOC



# HANDYLINK™ APPLICATION SPECIFICATION

## 6.4.2 Cradle Designs

### ○ Cup Style

The cup or holster style of cradle provides the greatest degree of alignment between mating connectors. Where the end product mass is greater than 1000 grams the use of supplemental alignment posts is recommended. The alignment posts' effective length (not including any lead-in taper) must be longer than the protrusion of the connector posts from the base surface of the cup-style receptacle. Further, the alignment posts' centerlines must lie in the same plane as the centerlines of the plug connector posts to provide the greatest benefits. Guide ribs are necessary on each side to limit front-to-back rocking motion as the device is loaded into the cup-style cradle.

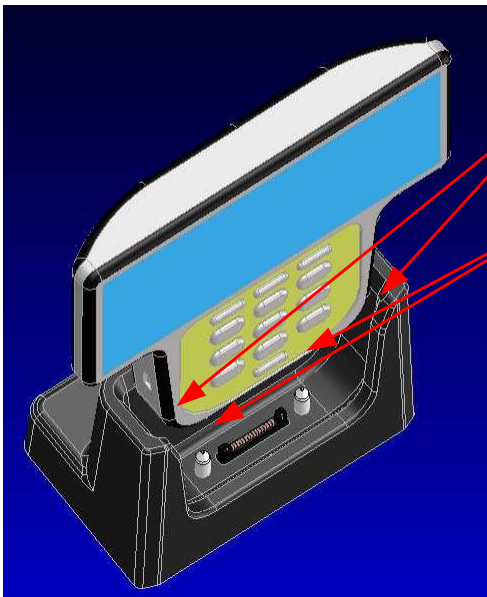

Guide Rails  
(each side)

Supplemental  
Alignment Posts

Figure 15. Cup-Style Cradle Features

NOTE: For details about mounting the connectors to the PCB and the use of fasteners, please refer to the applicable Sales Drawings.

<b>REVISION:</b>  <b>A</b>	<b>ECR/ECN INFORMATION:</b> EC No: <b>UCP2006- 1391</b> DATE: <b>2005/12/13</b>	<b>TITLE:</b>  <b>APPLICATION SPECIFICATION HANDYLINK™/I/O CONNECTOR SYSTEM</b>		<b>SHEET No.</b>  21 of 26
<b>DOCUMENT NUMBER:</b> <b>SD-45339-001</b>		<b>CREATED / REVISED BY:</b> <b>M. Simmel</b>	<b>CHECKED BY:</b> <b>Marc Simmel</b>	<b>APPROVED BY:</b> <b>Joe Comerci</b>

TEMPLATE FILENAME: PRODUCT\_SPEC[SIZE\_A](V.1).DOC



# HANDYLINK™ APPLICATION SPECIFICATION

Figures 16 and 17 show orthogonal views of showing differences in the position and size of the openings in the cradle casing, and the PCB location for the 45560 and 45593 connectors. Figure 18 shows a chamfer detail applicable to 45593.

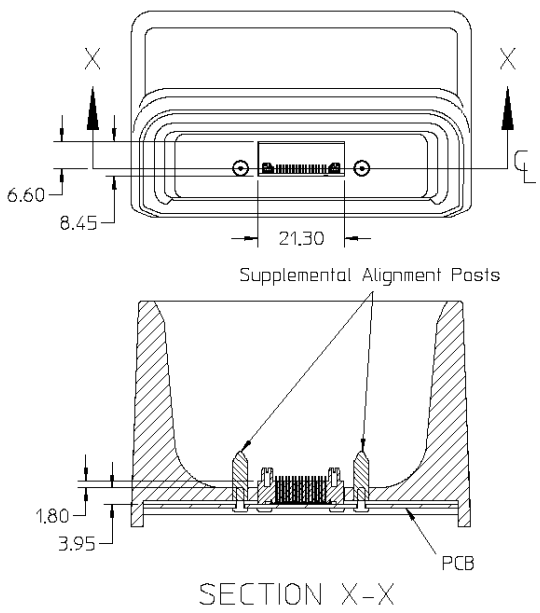

**Figure 16. Cradle Detail (45560)**  
(units: mm)

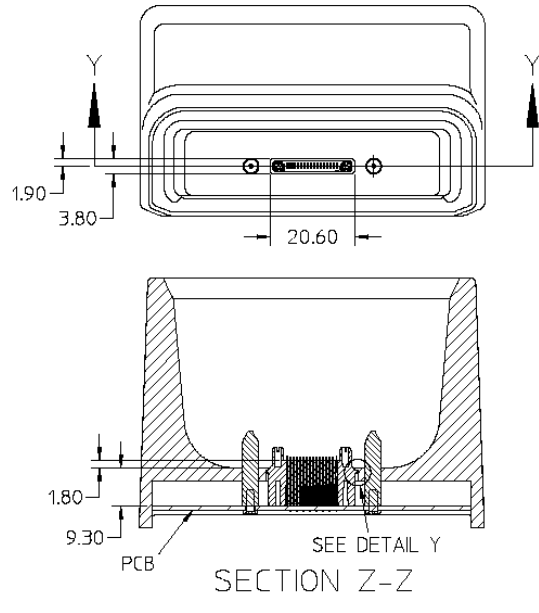

**Figure 17. Cradle Detail (45593)**  
(units: mm)

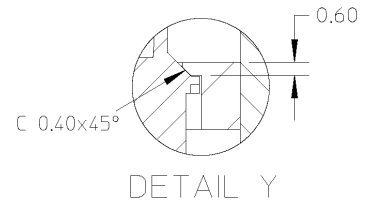

**Figure 18. Detail from Fig. 17.**  
(units: mm)

<b>REVISION:</b> <b>A</b>	<b>ECR/ECN INFORMATION:</b> EC No: <b>UCP2006- 1391</b> DATE: <b>2005/12/13</b>	<b>TITLE:</b> <b>APPLICATION SPECIFICATION HANDYLINK™/I/O CONNECTOR SYSTEM</b>	<b>SHEET No.</b> 22 of 26
<b>DOCUMENT NUMBER:</b> <b>SD-45339-001</b>	<b>CREATED / REVISED BY:</b> <b>M. Simmel</b>	<b>CHECKED BY:</b> <b>Marc Simmel</b>	<b>APPROVED BY:</b> <b>Joe Comerchi</b>

TEMPLATE FILENAME: PRODUCT\_SPEC[SIZE\_A](V.1).DOC



# HANDYLINK™ APPLICATION SPECIFICATION

○ **Shelf Style**

To achieve a 'rocking' disconnection for the end product from the cradle, a shelf style cradle design may be used under the following conditions:

- No supplemental guide posts may be used;
- The end product may not have more than 1000 grams mass;
- Side-to-side motion must be limited using end-walls or a guide rail;
- The vibration conditions of the end application must be limited.

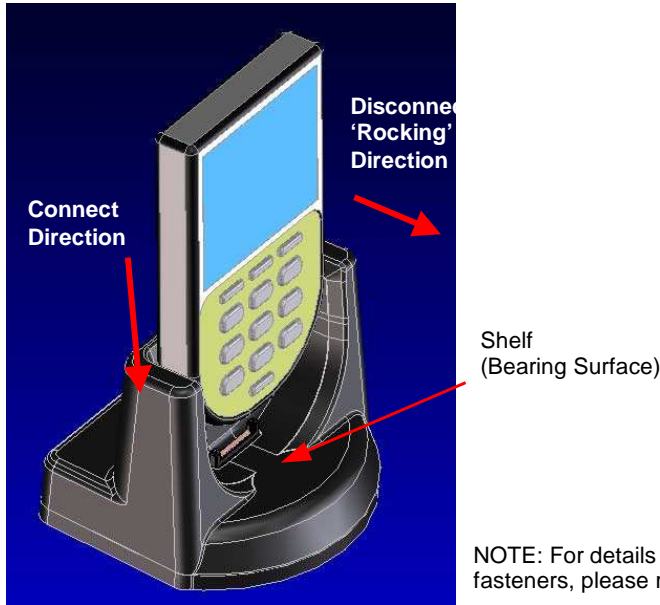

Figure 19. Shelf-Style Cradle Features

NOTE: For details about mounting the connectors to the PCB and the use of fasteners, please refer to the applicable Sales Drawings.

<u>REVISION:</u> <b>A</b>	<u>ECR/ECN INFORMATION:</u> EC No: <b>UCP2006- 1391</b> DATE: <b>2005/12/13</b>	<u>TITLE:</u> <b>APPLICATION SPECIFICATION HANDYLINK™/I/O CONNECTOR SYSTEM</b>	<u>SHEET No.</u> 23 of 26
<u>DOCUMENT NUMBER:</u> <b>SD-45339-001</b>		<u>CREATED / REVISED BY:</u> <b>M. Simmel</b>	<u>CHECKED BY:</u> <b>Marc Simmel</b>
		<u>APPROVED BY:</u> <b>Joe Comerchi</b>	

TEMPLATE FILENAME: PRODUCT\_SPEC[SIZE\_A](V.1).DOC



# HANDYLINK™ APPLICATION SPECIFICATION

In addition to the differences in the position and size of the openings in the cradle casing, the PCB location for the 45560 and 45593 connectors, and the chamfer detail applicable to 45593 that is shown in Figures 16 thru 18. Figures 20 through 22 illustrate details necessary to achieve a good 'rocking' design.

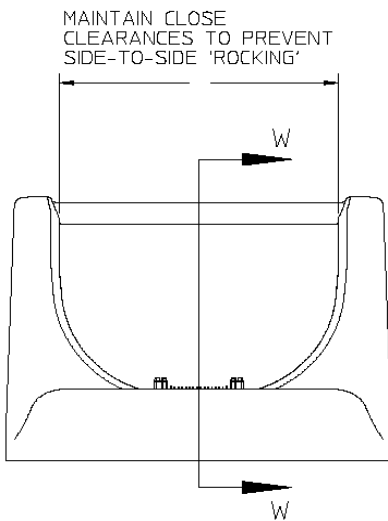

Figure 20. Front View of Shelf-Style Cradle

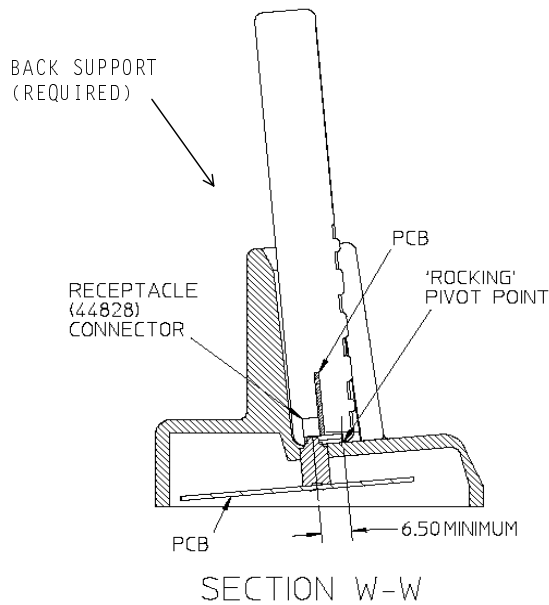

Figure 21. Section View of Shelf-Style Cradle (units: mm)

<u>REVISION:</u> <b>A</b>	<u>ECR/ECN INFORMATION:</u> EC No: <b>UCP2006- 1391</b> DATE: <b>2005/12/13</b>	<u>TITLE:</u> <b>APPLICATION SPECIFICATION HANDYLINK™/I/O CONNECTOR SYSTEM</b>	<u>SHEET No.</u> 24 of 26
<u>DOCUMENT NUMBER:</u> <b>SD-45339-001</b>		<u>CREATED / REVISED BY:</u> <b>M. Simmel</b>	<u>CHECKED BY:</u> <b>Marc Simmel</b>
		<u>APPROVED BY:</u> <b>Joe Comerchi</b>	

TEMPLATE FILENAME: PRODUCT\_SPEC[SIZE\_A](V.1).DOC





# HANDYLINK™ APPLICATION SPECIFICATION

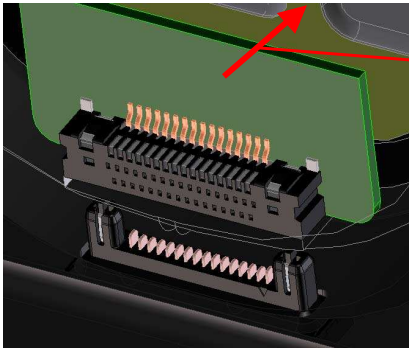

Rocking Direction

NOTE: Orientation of the receptacle connector and the plug or cradle connector must correspond to that shown for good operation of a 'rocking' design.

Figure 22. Connector Orientation

REVISION: <b>A</b>	ECR/ECN INFORMATION: EC No: <b>UCP2006- 1391</b> DATE: <b>2005/12/13</b>	TITLE: <b>APPLICATION SPECIFICATION HANDYLINK™/O CONNECTOR SYSTEM</b>	SHEET No. 25 of 26
DOCUMENT NUMBER: <b>SD-45339-001</b>	CREATED / REVISED BY: <b>M. Simmel</b>	CHECKED BY: <b>Marc Simmel</b>	APPROVED BY: <b>Joe Comerchi</b>

TEMPLATE FILENAME: PRODUCT\_SPEC[SIZE\_A](V.1).DOC



# HANDYLINK™ APPLICATION SPECIFICATION

## 7.0 Electrical Recommendations

### 7.1 Power Considerations

Please see the Product Specification, PS-44828-001, for the nominal electrical specifications. For applications where the sustained electrical power usage requirements exceed the limits stated in the product specification, the use of multiple circuits is suggested.

When the end-application is likely to encounter salt spray conditions, potential differences exceeding 4VDC should be separated by more than one terminal position (i.e. 1.6mm or more) to avoid galvanic corrosion between circuits.

### 7.2 High Speed Signal Transmission

Testing has shown that under the USB 2.0 Specification environment for connector components and cable assemblies (200 and 500 picosecond rise times), the HandyLink connectors perform within specification for both differential and common-mode impedance.

Full compliance testing on finished cable assemblies will have to be undertaken to verify the performance level of the finished product.

Contact Molex for further assistance regarding high speed signal transmission applications.

REVISION: <b>A</b>	ECR/ECN INFORMATION: EC No: <b>UCP2006- 1391</b> DATE: <b>2005/12/13</b>	TITLE: <b>APPLICATION SPECIFICATION HANDYLINK™/I/O CONNECTOR SYSTEM</b>	SHEET No. 26 of 26
DOCUMENT NUMBER: <b>SD-45339-001</b>	CREATED / REVISED BY: <b>M. Simmel</b>	CHECKED BY: <b>Marc Simmel</b>	APPROVED BY: <b>Joe Comerci</b>

TEMPLATE FILENAME: PRODUCT\_SPEC[SIZE\_A](V.1).DOC