

REVISOR		REVISIONS	
NO.	DATE	DESCRIPTION	BY
GP	00	SEE SHEET 1	

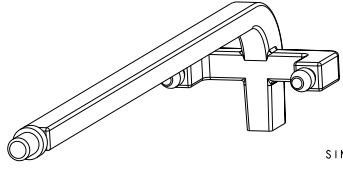

SINGLE LIGHT PIPE

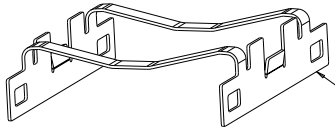

HEAT SINK CLIP

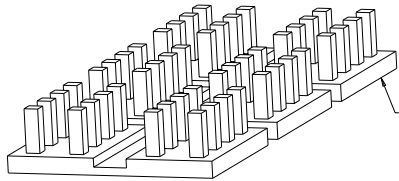

HEAT SINK

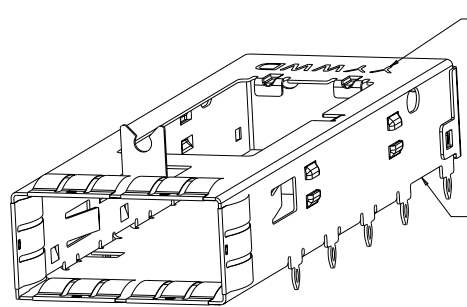

SINGLE QSFP CAGE W/ LIGHT PIPE HOLDER

EXPLODED ISOMETRIC VIEW
 SCALE 6:1

TITLE: CUSTOMER DRAWING DATE: 03/20/2007 DRAWN BY: [blank] CHECKED BY: [blank] APPROVED BY: [blank]		PART NUMBER: 188-2286 QUANTITY: 1 SPECIFICATION: [blank]		DRAWN BY: [blank] CHECKED BY: [blank] APPROVED BY: [blank]	
CUSTOMER DRAWING		PART NUMBER: 188-2286 QUANTITY: 1 SPECIFICATION: [blank]		DRAWN BY: [blank] CHECKED BY: [blank] APPROVED BY: [blank]	

DATE SHOWN IN DIMENSIONS RECEIVED FOR FABRICATION
 02/16/2007 BY TECH ELECTRONICS CORPORATION ALL RIGHTS RESERVED

REV. NO.		REVISIONS	
GP	00	DATE	BY

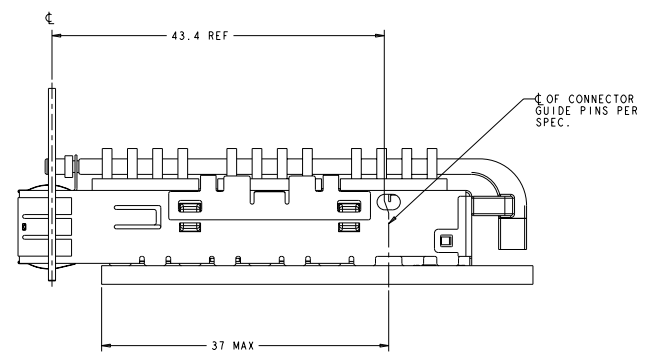
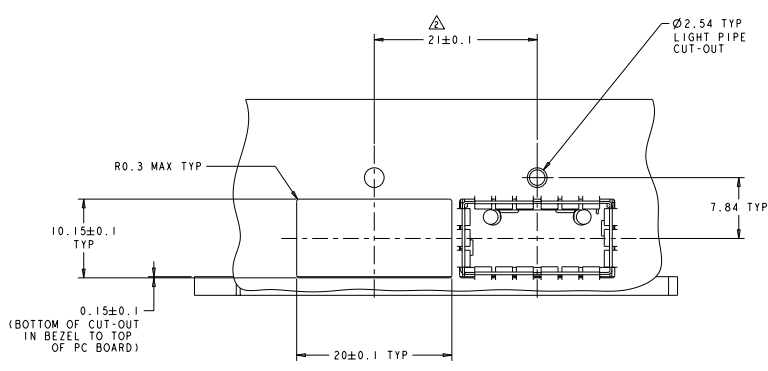

DATE: 02/16/2007 TIME: 10:00 AM DRAWN BY: J. B. BROWN CHECKED BY: J. B. BROWN APPROVED BY: J. B. BROWN		DATE: 02/16/2007 TIME: 10:00 AM DRAWN BY: J. B. BROWN CHECKED BY: J. B. BROWN APPROVED BY: J. B. BROWN		DATE: 02/16/2007 TIME: 10:00 AM DRAWN BY: J. B. BROWN CHECKED BY: J. B. BROWN APPROVED BY: J. B. BROWN	
TITLE: CAGE ASSEMBLY, THRU BEZEL, OSFP, W/ HEAT SINK AND SINGLE LIGHT PIPE		PART NO: 188-2286 SPECIFICATION NO: 116-13217		DRAWING NO: 00779 SHEET: 4 OF 4	

