

NUMBER  
C-1834027

METRIC  
3RD ANGLE PROJECTION

THIS INFORMATION IS CONFIDENTIAL AND IS DECIDED TO YOU ON CONDITION THAT NO FURTHER DISCLOSURE IS MADE BY YOU TO OTHER THAN AMP PERSONNEL WITHOUT DIMENSIONS IN MILLIMETERS. DO NOT SCALE PRINT.

PRINT  
DW

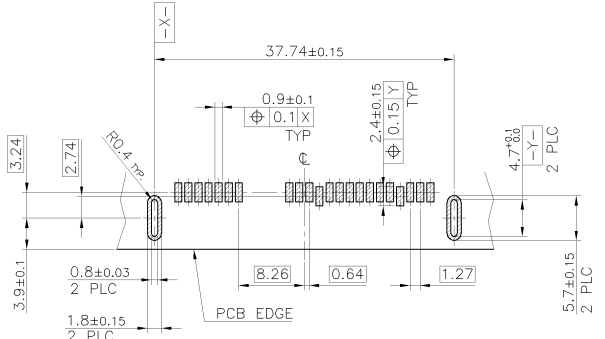
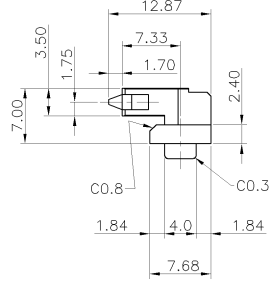
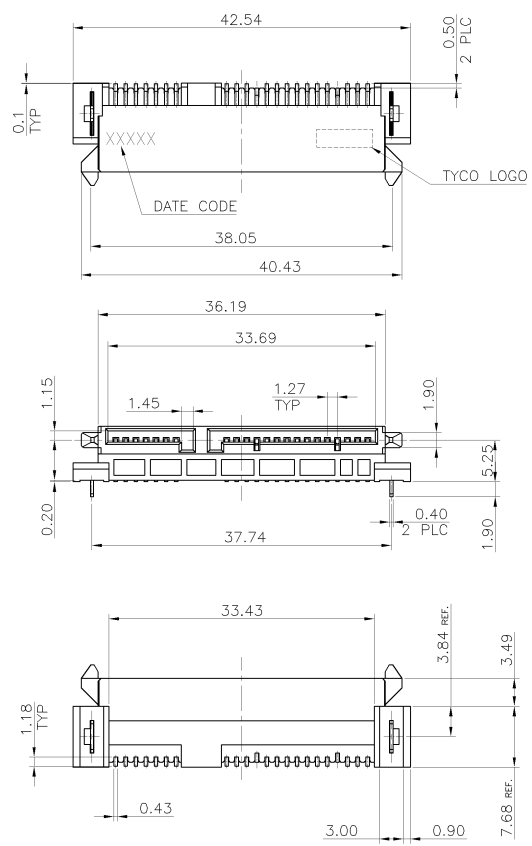

RECOMMENDED P.C.B. LAYOUT (THICKNESS=1.2)

- NOTE:
- MATERIAL:  
HOUSING: HIGH TEMP. THERMOPLASTIC UL 94V-0,  
COLOR: BLACK.  
CONTACTS: PHOSPHOR BRONZE.  
BOARDLOCKS: BRASS.
  - FINISH:  
CONTACTS: 20µ" MIN. GOLD PLATED ON CONTACT AREA,  
GOLD FLASH ON SOLDER TAILS, WITH ENTIRE  
CONTACT UNDERPLATED 50µ" MIN. NICKEL.  
BOARDLOCKS: 100µ" MIN. MATTE-TIN OVER 50µ" MIN.  
NICKEL PLATED.

1834027-1  
PART NUMBER

TOLERANCES UNLESS OTHERWISE SPECIFIED:	DWN	A. WU	<b>tyco</b>	TYCO HOLDINGS (BERMUDA)
0 PLC ±	20-SEP-2005	S. HOU	<b>Electronics</b>	VII LTD. TAIWAN BRANCH
1 PLC ±0.38		20-SEP-2005	NAME	
2 PLC ±0.25			PRODUCT SPEC	SERIAL ATA ASSY, 22 POSITION, SMT, R/A, RVS, RECEPTACLE 5.25 CL
3 PLC ±0.13			108-57514	
ANGLES ±3°			QUALIFICATION TEST REPORT	LOC SIZE DRAWING NO
			501-57587	DW A <sub>3</sub> C-1834027
			WEIGHT	SCALE SHEET
			2.4 g	-- 1 OF 2

0	FIRST RELEASED	--	AW	12SEP
LTR	REVISION RECORD	ECN	DWN	2005
			CHK	DATE

8 7 6 5 4 3 2 1 CUSTOMER DRAWING

D  
C  
B  
A

NUMBER C-1834027



METRIC

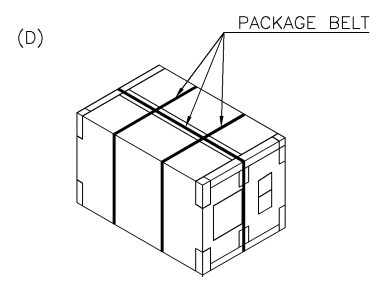
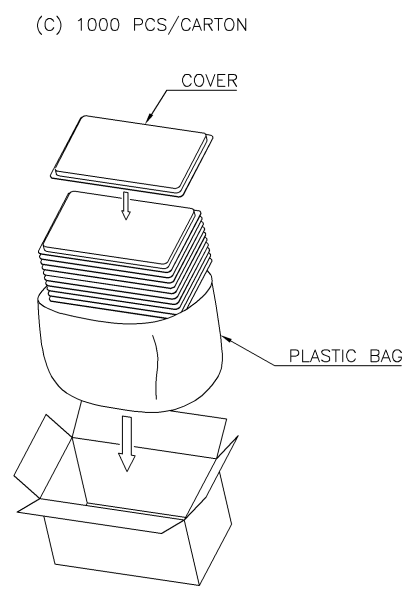
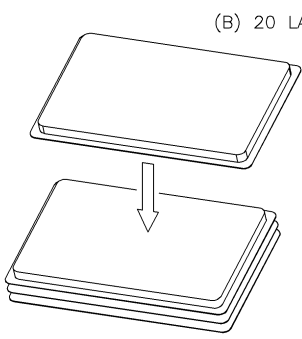
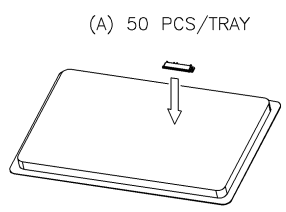

THIS INFORMATION IS CONFIDENTIAL AND IS DECIDED TO YOU ON CONDITION THAT NO FURTHER DISCLOSURE IS MADE BY YOU TO OTHER THAN AMP PERSONNEL WITHOUT DIMENSIONS IN MILLIMETERS. DO NOT SCALE PRINT.

PRINT DIST  
DW

SEE SHEET 1.	ECN	DWN/CHK	DATE
LTR	REVISION RECORD	ECN	DWN/CHK

3.4 Kg	2.4 Kg	340 X 240 X 215	50	20	1000 PCS
GROSS WEIGHT	NET WEIGHT	CARTON DIMENSION	PCS/TRAY	TRAYS	QUANTITY
TOLERANCES UNLESS OTHERWISE SPECIFIED:		DWN	A. WU 20-SEP-2005		
0 PLC ±	1 PLC ±	CHK	S. HOU 20-SEP-2005		
2 PLC ±	3 PLC ±	APVD			
ANGLES ±		W.J. KE 20-SEP-2005			
MATERIAL		PRODUCT SPEC			
-		APPLICATION SPEC			
FINISH		WEIGHT			
-		LOC SIZE DRAWING NO			
		DW A <sub>3</sub> C-1834027			
		SCALE SHEET			
		-- 2 OF 2			

CUSTOMER DRAWING