

NUMBER C-1775429

METRIC

PRINT DIST DW

THIS INFORMATION IS CONFIDENTIAL AND IS RELEASED TO YOU ON CONDITION THAT NO FURTHER DISCLOSURE IS MADE BY YOU TO OTHER THAN AMP PERSONNEL WITHOUT DIMENSIONS IN MILLIMETERS. DO NOT SCALE PRINT.

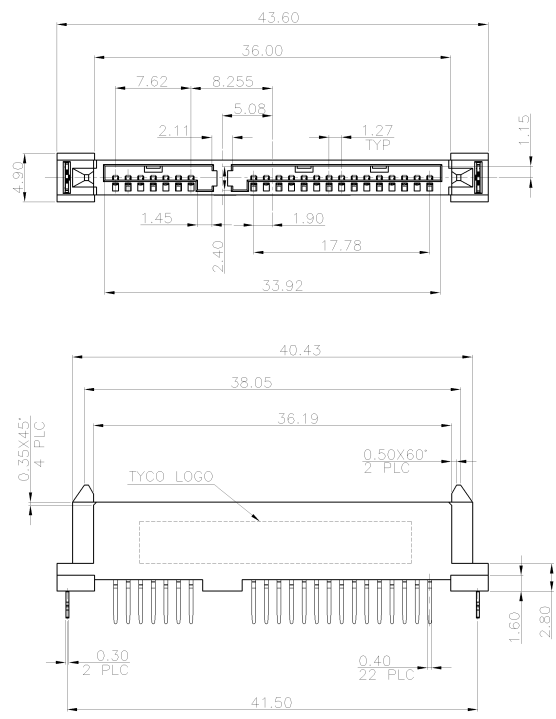

NOTE:

- MATERIAL:
HOUSING: LCP WITH 30% GF, UL 94V-0, BLACK COLOR.
CONTACTS: PHOSPHOR BRONZE.
BOARDLOCKS: BRASS.
- FINISH:
CONTACTS: (SEE TABLE) GOLD PLATED ON CONTACT AREA, 2.54μm [100μ"] MIN. MATTE-TIN ON SOLDER TAIL, WITH ENTIRE CONTACT UNDERPLATED 1.27μm [50μ"] MIN. NICKEL.
BOARDLOCK: 2.54μm [100μ"] MIN. MATTE-TIN OVER 1.27μm [50μ"] MIN. NICKEL.
- WAVE SOLDER CAPABLE TO 265°C PER TYCO SPEC. 109-202, CONDITION B.

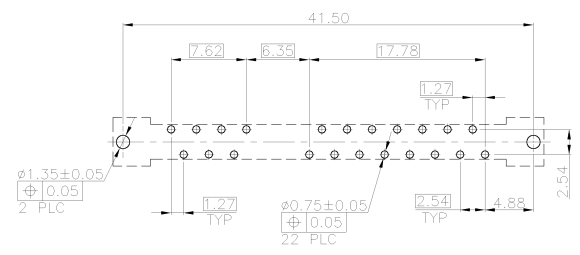

TOLERANCE: ±0.05, THICKNESS: 2.3 mm
RECOMMENDED PCB LAYOUT

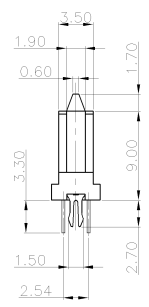

| | |
|---------------------|-------------|
| 0.762μm [30μ"] | 1775429-3 |
| 0.381μm [15μ"] | 1775429-2 |
| GOLD FLASH | 1775429-1 |
| MIN. GOLD THICKNESS | PART NUMBER |

| | | | | | | |
|--|---------------------------|-------------|---|----------------|------------|-----|
| TOLERANCES UNLESS OTHERWISE SPECIFIED: | DWN | A. WU | tyco | | | |
| 0 PLC ± | CHK | 28-JUL-2006 | TYCO HOLDINGS (BERMUDA) VII LTD. TAIWAN BRANCH | | | |
| 1 PLC ±0.3 | | | NAME | | | |
| 2 PLC ±0.25 | | | SERIAL ATA CONNECTOR, 22 POSN RCPT DIP VERTICAL | | | |
| 3 PLC ±0.2 | | | SCALE | | | |
| ANGLES ±3° | | | SHEET | | | |
| MATERIAL | APVD | W.J. KE | LOC | SIZE | DRAWING NO | REV |
| SEE NOTE | | 28-JUL-2006 | DW | A ₃ | C-1775429 | A |
| FINISH | QUALIFICATION TEST REPORT | 501-57654 | SCALE | SHEET | | |
| SEE NOTE | WEIGHT | 1.5 GRAMS | 1 OF 2 | | | |

| | | | | | |
|-----|-----------------|-----|-----|-----|------------|
| | | | | | |
| A | FIRST RELEASED | -- | AW | SH | 28JUL 2006 |
| LTR | REVISION RECORD | ECN | DWN | CHK | DATE |

CUSTOMER DRAWING

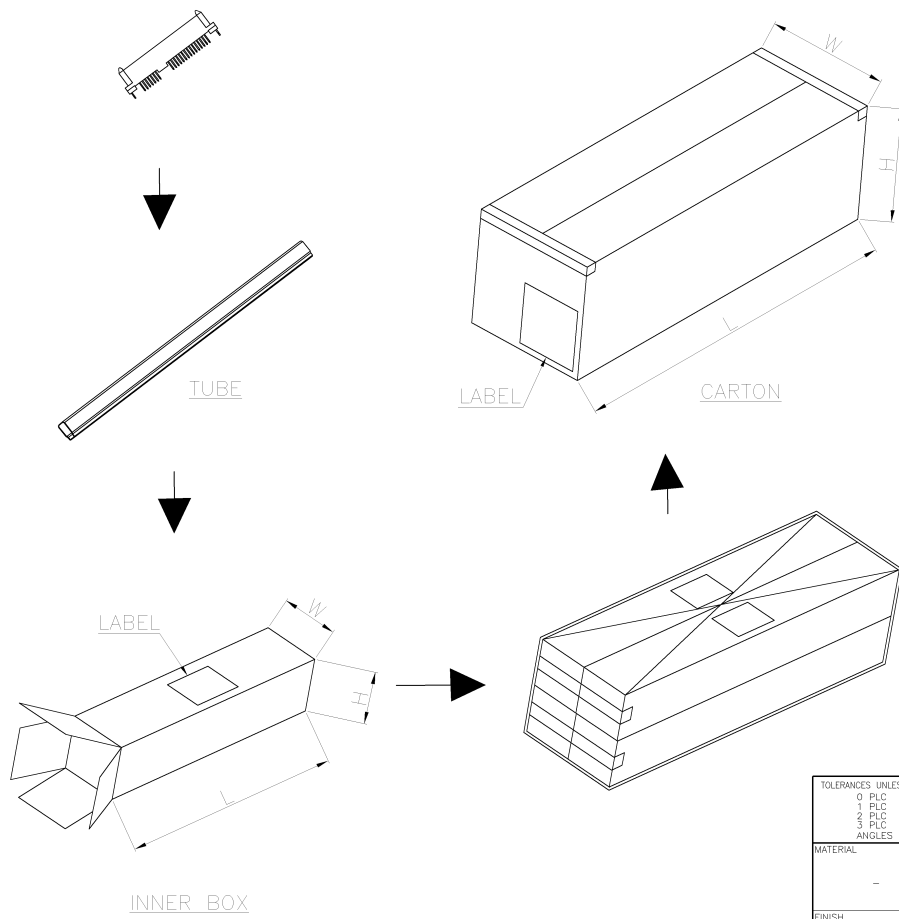

- NOTE:
1. DIMENSION:
 TUBE: L= 460, W= 6.5, H= 16.5 mm
 INNER BOX: L= 485, W= 86, H= 72 mm
 CARTON: L= 500, W= 187, H= 169 mm
 2. QUANTITY:
 10 PCS/TUBE
 48 TUBES/INNER BOX
 4 INNER BOX/CARTON
 1920 PCS/CARTON
 3. WEIGHT:
 N.W: 3 KG
 G.W: 6.8 KG

| | | | |
|-------------|-----------------|---------|------|
| SEE SHEET 1 | ECN | DWN/CHK | DATE |
| LTR | REVISION RECORD | | |

| | | | | |
|--|---------------------------|-------------|-------------------------------------|--------------------------|
| TOLERANCES UNLESS OTHERWISE SPECIFIED: | DWN | A. WU | tyco TYCO HOLDINGS (BERMUDA) | |
| 0 PLC ± | CHK | 28-JUL-2006 | VII LTD. TAIWAN BRANCH | |
| 1 PLC ± | | | NAME | |
| 2 PLC ± | | | SERIAL ATA CONNECTOR, | |
| 3 PLC ± | | | 22 POSN RCPT DIP VERTICAL | |
| ANGLES ± | | | LOC SIZE DRAWING NO | |
| MATERIAL | APVD | W.J. KE | DW | A ₃ C-1775429 |
| - | | 28-JUL-2006 | SCALE | SHEET |
| FINISH | QUALIFICATION TEST REPORT | | | 2 OF 2 |
| - | | | | |
| WEIGHT | | | | |
| - | | | | |