

4

3

2

1

THIS DRAWING IS UNPUBLISHED. RELEASED FOR PUBLICATION
 © COPYRIGHT BY TYCO ELECTRONICS CORPORATION. ALL RIGHTS RESERVED.

LOC	DIST	REVISIONS					
DW	-	P	LTR	DESCRIPTION	DATE	DWN	APVD
		D		ECR-09-010246	06MAY09	AW	WK

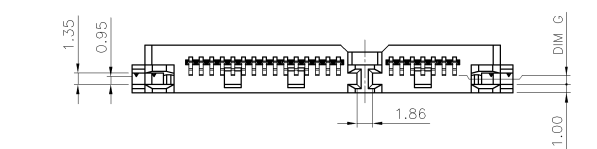
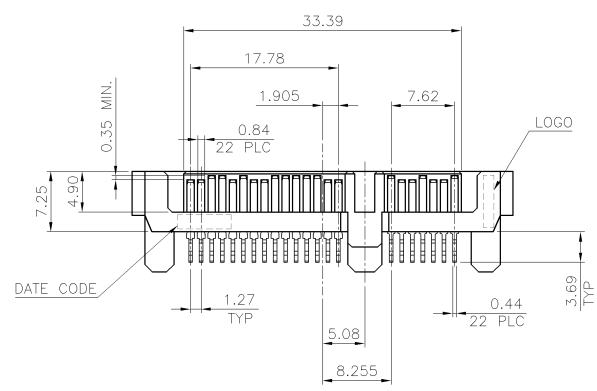
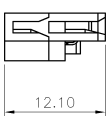
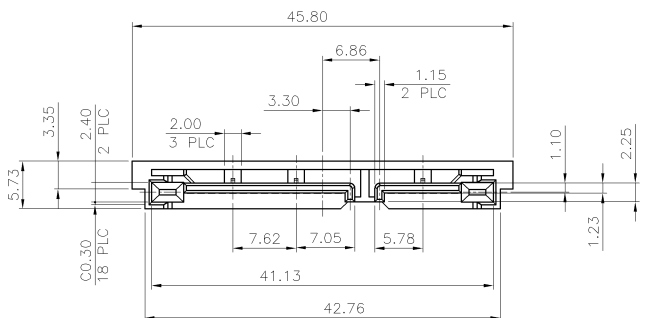

- NOTE:
- MATERIAL:
HOUSING: LCP WITH 30% GF, UL 94V-0, BLACK COLOR.
CONTACTS: PHOSPHOR BRONZE.
 - FINISH:
CONTACTS: (SEE TABLE) GOLD PLATED ON CONTACT AREA, 2.54μm [100μ"] MIN. MATTE-TIN ON SOLDER TAIL, WITH ENTIRE CONTACT UNDERPLATED 1.27μm [50μ"] MIN. NICKEL.
 - REFLOW SOLDER CAPABLE TO 260°C PER TEC-109-201, CONDITION B.

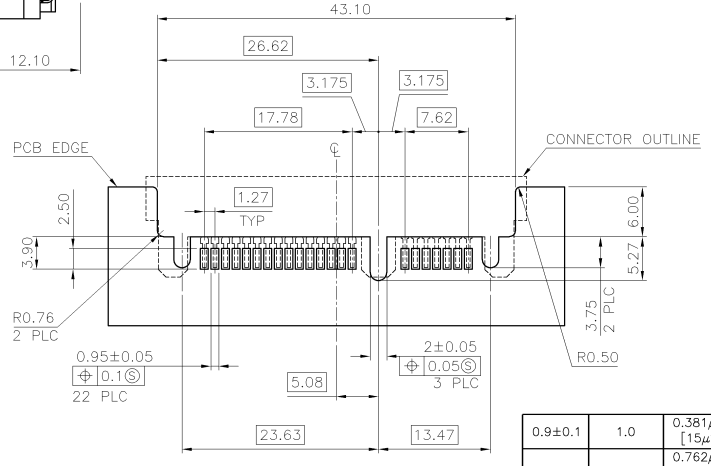

TOLERANCE: ±0.05, THICKNESS: (SEE TABLE)
 RECOMMENDED PCB LAYOUT (TOP VIEW)

0.9±0.1	1.0	0.381μm [15μ"]	1734750-4
1.06±0.08	1.2	0.762μm [30μ"]	1734750-3
		0.381μm [15μ"]	1734750-2
		GOLD FLASH	1734750-1
DIM G	PCB THICKNESS	MIN. GOLD THICKNESS	PART NUMBER

THIS DRAWING IS A CONTROLLED DOCUMENT.

DIMENSIONS:	TOLERANCES UNLESS OTHERWISE SPECIFIED:	DWN	10JAN2007	Tyco Electronics Corporation Taipei, Taiwan			
MM	0 PLC ± -	CHK	10JAN2007				
	1 PLC ± 0.3	APVD	10JAN2007				
	2 PLC ± 0.25	NAME					
	3 PLC ± 0.2	PRODUCT SPEC	108-57564	SERIAL ATA CONNECTOR, 22 POSITION, COMBO PLUG, STRADDLE, REVERSED			
	4 PLC ± -	APPLICATION SPEC					
MATERIAL	FINISH	WEIGHT	1.92 GRAMS	SIZE	CAGE CODE	DRAWING NO	RESTRICTED TO
SEE NOTE	SEE NOTE	CUSTOMER DRAWING		A3	00779	1734750	-
			SCALE	SHEET	1 OF 2	REV	D

4

3

2

1

THIS DRAWING IS UNPUBLISHED. RELEASED FOR PUBLICATION
 © COPYRIGHT BY TYCO ELECTRONICS CORPORATION. ALL RIGHTS RESERVED.

LOC	DIST	REVISIONS			
P	LTR	DESCRIPTION	DATE	DWN	APVD
		SEE SHEET 1.			

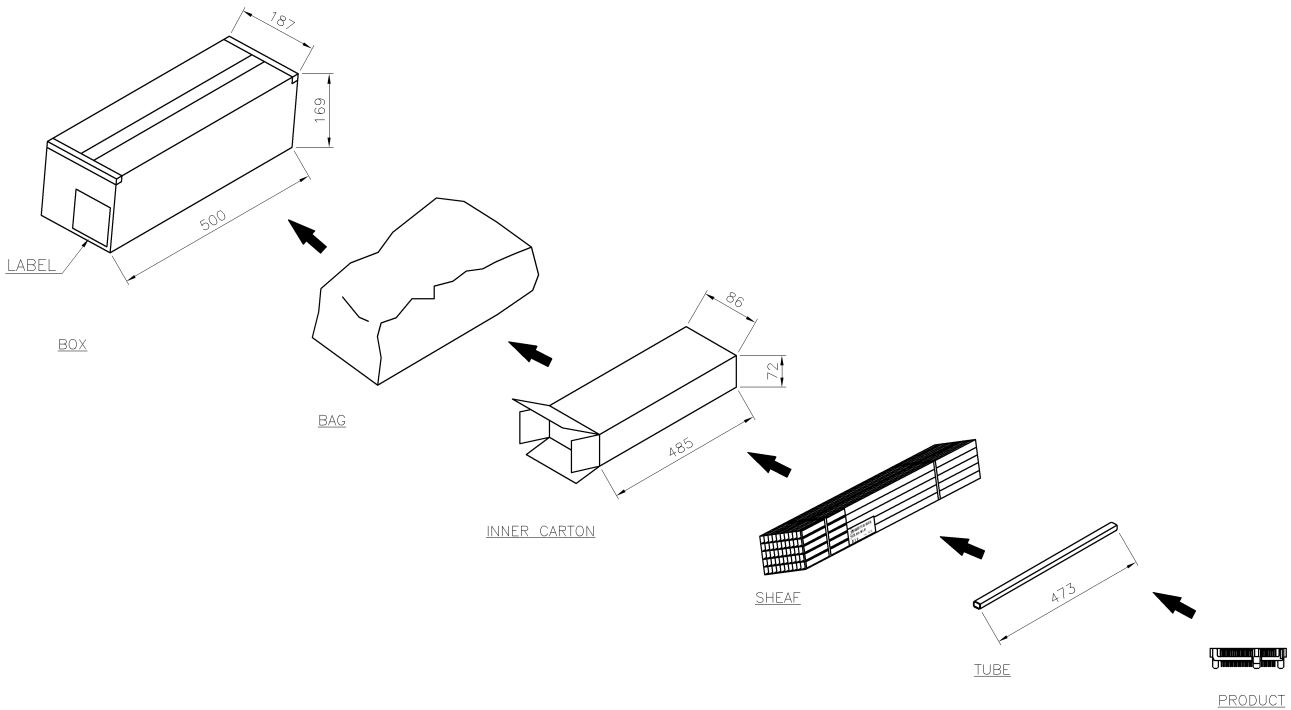

10	50	1	4	2000 PCS	7.80 KG	3.80 KG
PCS/TUBE	TUBES/SHEAF	SHEAFS/INNER	INNER/CARTON	QUANTITY	GROSS WEIGHT	NET WEIGHT

THIS DRAWING IS A CONTROLLED DOCUMENT.		DWN A. WU 10JAN2007	Tyco Electronics Corporation Taipei, Taiwan	
DIMENSIONS: MM		CHK S. HOU 10JAN2007		
TOLERANCES UNLESS OTHERWISE SPECIFIED: 0 PLC ±.1 1 PLC ±.15 2 PLC ±.2 3 PLC ±.25 4 PLC ±.3 ANGLES ±.5		APVD W.J. KE 10JAN2007	NAME SERIAL ATA CONNECTOR, 22 POSITION, COMBO PLUG, STRADDLE, REVERSED	
MATERIAL		PRODUCT SPEC	SIZE CAGE CODE DRAWING NO A3 00779 C-1734750	
FINISH		APPLICATION SPEC	RESTRICTED TO	
		WEIGHT	CUSTOMER DRAWING	
			SCALE	SHEET 2 OF 2 REV D