

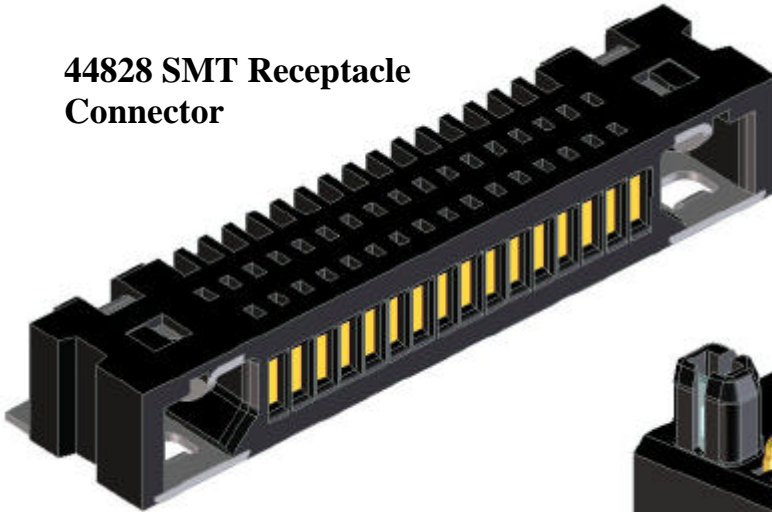

PRELIMINARY HANDYLINK™ APPLICATION SPECIFICATION

HANDYLINK™ I/O CONNECTORS

**44828 SMT Receptacle
Connector**



**45560 SMT Cradle
Connector**

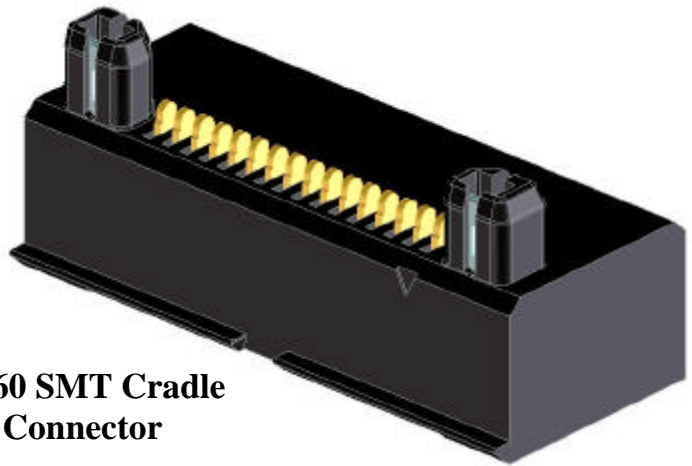

**45339 and 45593
Plug Connector Modules**



REVISION: A	ECR/ECN INFORMATION: EC.No: UCP2004-2588 DATE: 6/24/04	TITLE: APPLICATION SPECIFICATION HANDYLINK™/I/O CONNECTOR SYSTEM		SHEET No. 1 of 21
DOCUMENT NUMBER: AS-44828-001		CREATED / REVISED BY: T. Gregori/ M. Simmel	CHECKED BY: Marc Simmel	APPROVED BY: Joe Comerchi

TEMPLATE FILENAME: PRODUCT_SPEC[SIZE_A](V.1).DOC



PRELIMINARY HANDYLINK™ APPLICATION SPECIFICATION

Table of Contents

<u>Section</u>	<u>Page</u>
1.0 Scope	3
2.0 Product Description	3
3.0 Applicable Documents and Specifications	3
4.0 Mating and Un-Mating of Connectors	
4.1 Recommendations for Mating and Un-Mating	4
4.2 Mating Alignment Tolerances	4
5.0 Soldering Process Recommendations	
5.1 44828 SMT Receptacle Connector	6
5.1.1 PCB Layout	
5.1.2 Solder Paste Stencil Layout	
5.1.3 Reflow Profile	
5.1.4 Inspection	
5.2 45560 SMT Cradle Connector	6
5.2.1 PCB Layout	
5.2.2 Solder Paste Stencil Layout	
5.2.3 Reflow Profile	
5.2.4 Inspection	
5.3 45339 Plug Module for Wire Termination	7
5.3.1 Applicable Wire Sizes	
5.3.2 Wire Preparation	
5.3.3 Inspection	
5.4 45593 Plug Module for PCB Termination	7
5.4.1 PCB Layout	
5.4.2 Inspection	
6.0 Mechanical Design Recommendations	
6.1 Mechanical Fasteners and Support	8
6.1.1 Receptacle Connector	
6.1.2 Plug Connector Modules	
6.1.3 Cradle Connector	
6.2 Ingress Protection	10
6.3 Plug Cable Over-Molding	11
6.3.1 Wire Soldering	
6.3.2 Encapsulation	
6.3.3 Strain Relief	
6.3.4 Final Over-Molding	
6.4 Design Best Practices	14
6.4.1 Plug Over-mold Designs	
6.4.2 Cradle Designs	
7.0 Electrical Recommendations	
7.1 Power Considerations	21
7.2 High Speed Signal Transmission	21

<u>REVISION:</u> A	<u>ECR/ECN INFORMATION:</u> <u>EC No:</u> UCP2004-2588 <u>DATE:</u> 6/24/04	<u>TITLE:</u> APPLICATION SPECIFICATION HANDYLINK™/O CONNECTOR SYSTEM	<u>SHEET No.</u> 2 of 21
<u>DOCUMENT NUMBER:</u> AS-44828-001	<u>CREATED / REVISED BY:</u> T. Gregori/ M. Simmel	<u>CHECKED BY:</u> Marc Simmel	<u>APPROVED BY:</u> Joe Comerçi

TEMPLATE FILENAME: PRODUCT_SPEC[SIZE_A](V.1).DOC



PRELIMINARY HANDYLINK™ APPLICATION SPECIFICATION

1.0 SCOPE

This specification addresses the manufacturing techniques and end-usage considerations for Molex's 0.8mm pitch HandyLink™ I/O Connectors. The common contact interface used in this family of connectors consists of a flat pad mated to a radiussed edge on a compression spring blade. The flat pad is enclosed by plastic in an over-molded receptacle housing which provides a sealed interface to facilitate ingress protection. The compression spring blades are extremely durable and are capable of sustaining over 20,000 mating cycles. Two "passive" latches counteract the compression springs to keep the connector pairs mated but enable simple disconnection by the end-user.

The customer is encouraged to contact Molex with any questions regarding the application of this product.

2.0 PRODUCT DESCRIPTION

2.1 Product Names and Part Numbers

SMT Receptacle Connectors

Series: 44828

SMT Cradle Connectors

Series 45560 (Perpendicular and Parallel Mating)

Plug Connector Modules

Series 45339 (Wire Termination)

Series 45593 (PCB Termination)

2.2 Dimensions, Materials, Platings, and Markings

(See applicable sales drawings for information)

3.0 APPLICABLE DOCUMENTS AND SPECIFICATIONS

Product Specification PS-44828-001

Sales Drawing SD-44828-162

Sales Drawing SD-45560-160, SD-45560-161, SD-45560-162

Sales Drawing SD-45339-160, SD-45593-160

<u>REVISION:</u> A	<u>ECR/ECN INFORMATION:</u> EC No: UCP2004-2588 DATE: 6/24/04	<u>TITLE:</u> APPLICATION SPECIFICATION HANDYLINK™ I/O CONNECTOR SYSTEM		<u>SHEET No.</u> 3 of 21
<u>DOCUMENT NUMBER:</u> AS-44828-001		<u>CREATED / REVISED BY:</u> T. Gregori/ M. Simmel	<u>CHECKED BY:</u> Marc Simmel	<u>APPROVED BY:</u> Joe Comerçi

TEMPLATE FILENAME: PRODUCT_SPEC[SIZE_A](V.1).DOC



PRELIMINARY HANDYLINK™ APPLICATION SPECIFICATION

4.0 MATING AND UN-MATING OF CONNECTORS

This section describes the preferred methods for mating and un-mating the HandyLink™ connectors.

4.1 Recommendations for Mating and Un-Mating

This connector system utilizes a “passive” latching feature. There is no button to press to latch or unlatch. To latch, simply push the plug into the receptacle (the connectors are polarized to discourage improper mating). To unlatch, simply grip the plug body firmly and pull it straight out of the receptacle.

4.2 Mating Alignment Tolerances

4.2.a 44828 Receptacle to 45339 or 45593 Plug Connectors

The HandyLink™ plug and receptacle have been appropriately designed and toleranced to be mated and unmated by hand. The connectors’ alignment features are manufactured with clearances to allow axial mating mis-alignment, as illustrated in the Figure 1, below:

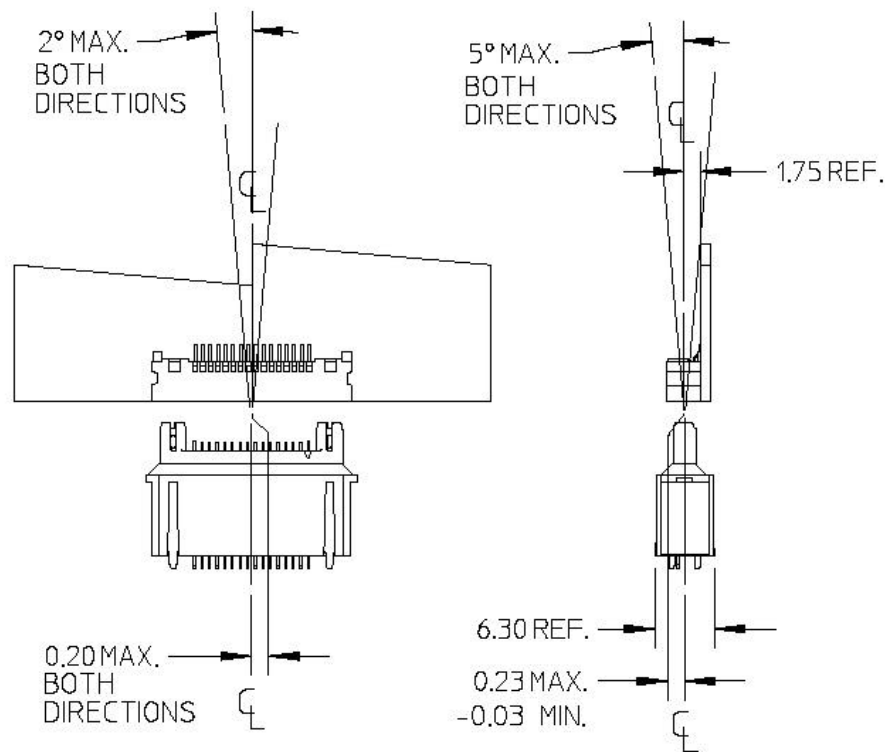

Figure 1. Receptacle to Plug Connector Axial Alignment (units: mm)

REVISION: A	ECR/ECN INFORMATION: EC No: UCP2004-2588 DATE: 6/24/04	TITLE: APPLICATION SPECIFICATION HANDYLINK™/O CONNECTOR SYSTEM		SHEET No. 4 of 21
DOCUMENT NUMBER: AS-44828-001	CREATED / REVISED BY: T. Gregori/ M. Simmel	CHECKED BY: Marc Simmel	APPROVED BY: Joe Comerchi	
TEMPLATE FILENAME: PRODUCT_SPEC[SIZE_A](V.1).DOC				



PRELIMINARY HANDYLINK™ APPLICATION SPECIFICATION

4.2 Mating Alignment Tolerances (continued)

4.2.b 44828 Receptacle to 45560 Cradle Connectors

The HandyLink™ receptacle and cradle connectors' alignment features are manufactured with clearances to allow some axial mating mis-alignment as illustrated in the Figure 2, below:

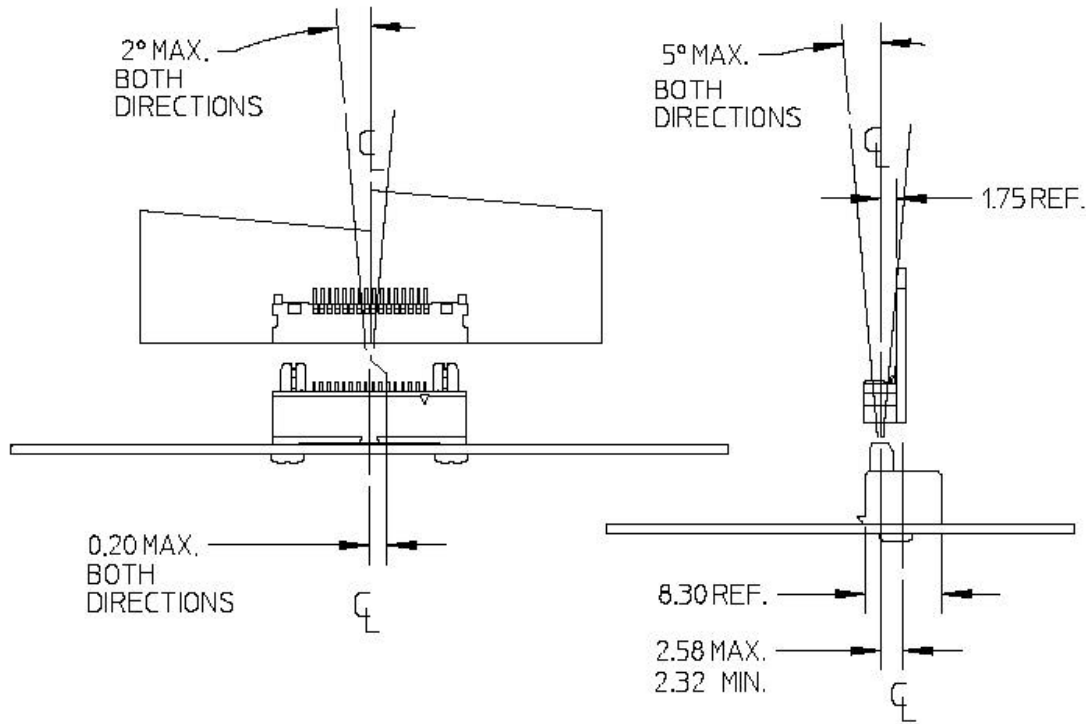

Figure 2. Receptacle to Cradle Connector Axial Alignment (units: mm)

NOTE: Mating misalignment may significantly influence the long-term durability of the connectors. The risk of housing wear diminishes with increasing the accuracy of connector alignment.

REVISION: A	ECR/ECN INFORMATION: EC No: UCP2004-2588 DATE: 6/24/04	TITLE: APPLICATION SPECIFICATION HANDYLINK™/O CONNECTOR SYSTEM		SHEET No. 5 of 21
DOCUMENT NUMBER: AS-44828-001		CREATED / REVISED BY: T. Gregori/ M. Simmel	CHECKED BY: Marc Simmel	APPROVED BY: Joe Comerchi
TEMPLATE FILENAME: PRODUCT_SPEC[SIZE_A](V.1).DOC				



PRELIMINARY HANDYLINK™ APPLICATION SPECIFICATION

5.0 SOLDERING PROCESS RECOMMENDATIONS

5.1 44828 SMT Receptacle Connector

5.1.1 PCB Layout

See the applicable Sales Drawing for an illustration of the recommended PCB layout. Contact Molex if further assistance is required.

5.1.2 Solder Paste Stencil Layout

See Sales Drawing for solderable surfaces. Contact Molex if further assistance is required.

5.1.3 Reflow Profile

While the production solder reflow profile is typically established by the customer, based on their specific application, generic reflow profiles can be found in Product Specification PS-44828-001. The profiles are provided for reference purposes only.

5.1.4 Inspection

Solder joints should be inspected using established conventional methods.

5.2 45560 SMT Cradle Connector

5.2.1 PCB Layout

See the applicable Sales Drawings for illustrations of the recommended PCB pad layouts. Contact Molex if further assistance is required.

5.2.2 Solder Paste Stencil Layout

See Sales Drawing for recommended PCB pad layout and solder paste thickness.

5.2.3 Reflow Profile

While the production solder reflow profile is typically established by the customer, based on their specific application, generic reflow profiles can be found in Product Specification PS-44828-001. The profiles are provided for reference purposes only.

5.2.4 Inspection

Solder joints should be inspected using established conventional methods.

REVISION: A	ECR/ECN INFORMATION: EC No: UCP2004-2588 DATE: 6/24/04	TITLE: APPLICATION SPECIFICATION HANDYLINK™/O CONNECTOR SYSTEM		SHEET No. 6 of 21
DOCUMENT NUMBER: AS-44828-001		CREATED / REVISED BY: T. Gregori/ M. Simmel	CHECKED BY: Marc Simmel	APPROVED BY: Joe Comerchi

TEMPLATE FILENAME: PRODUCT_SPEC[SIZE_A](V.1).DOC



PRELIMINARY HANDYLINK™ APPLICATION SPECIFICATION

5.3 45339 Plug Module for Wire Termination

5.3.1 Applicable Wire Sizes

Copper conductor size: 22 to 28 AWG (stranded wires are recommended for flexibility)

Maximum insulation diameter: 1.6mm

5.3.2 Wire Preparation

Strip length: 2.0 ~ 2.5mm

Pre-tinning is recommended.

5.3.3 Inspection

Solder joints should be inspected using established conventional methods.

5.4 45593 Plug Module for PCB Termination

5.4.1 PCB Layout

See the applicable Sales Drawing for an illustration of the recommended PCB hole layout.

5.4.2 Inspection

Solder joints should be inspected using established conventional methods.

REVISION: A	ECR/ECN INFORMATION: EC No: UCP2004-2588 DATE: 6/24/04	TITLE: APPLICATION SPECIFICATION HANDYLINK™/O CONNECTOR SYSTEM	SHEET No. 7 of 21
DOCUMENT NUMBER: AS-44828-001	CREATED / REVISED BY: T. Gregori/ M. Simmel	CHECKED BY: Marc Simmel	APPROVED BY: Joe Comerchi

TEMPLATE FILENAME: PRODUCT_SPEC[SIZE_A](V.1).DOC



PRELIMINARY HANDYLINK™ APPLICATION SPECIFICATION

6.0 MECHANICAL MOUNTING RECOMMENDATIONS

6.1 Mechanical Fasteners and Support

6.1.1 Receptacle Connector

Molex recommends that the receptacle connector be mounted within the end-application enclosure such that it is recessed by 1.6 to 2.4mm from the outermost faces and with a 0.10mm maximum clearance with the casing inner walls. Such a recess provides multiple advantages in terms of protecting the contact surfaces from accidental impact, providing mechanical support when the mating plug connector assembly is torqued by abusive handling, and helps to reduce direct contact with hand oils or other contamination. See Figures 3A and 3B, below, for recommendations on recess dimensions.

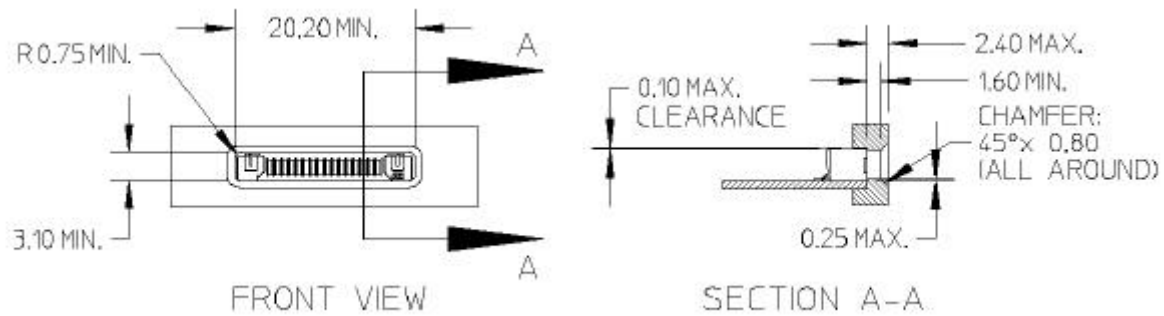

Figure 3A. Receptacle Connector Recess When Mating with the Plug Only (units: mm)

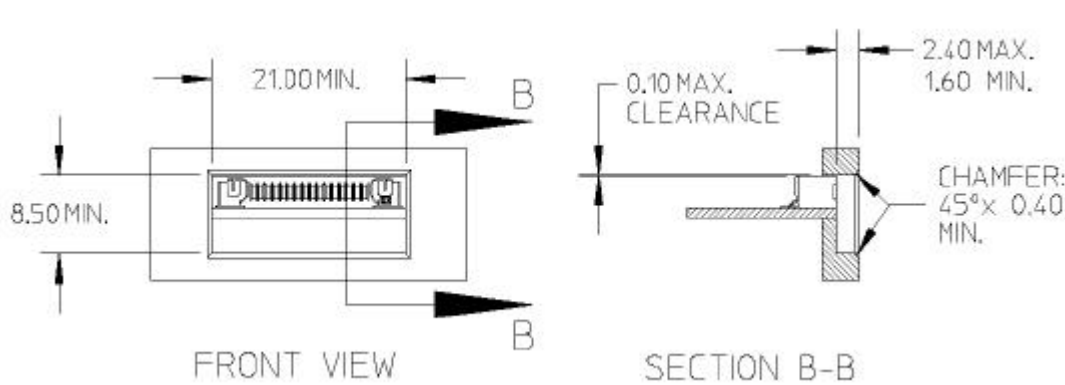

Figure 3B. Receptacle Connector Recess When Mating with the Plug or Cradle Connectors (units: mm)

Wherever possible, the 0.10 maximum clearance condition with the receptacle should be minimized by utilizing a clam-shell style package design.

REVISION: A	ECR/ECN INFORMATION: EC No: UCP2004-2588 DATE: 6/24/04	TITLE: APPLICATION SPECIFICATION HANDYLINK™/O CONNECTOR SYSTEM		SHEET No. 8 of 21
DOCUMENT NUMBER: AS-44828-001		CREATED / REVISED BY: T. Gregori/ M. Simmel	CHECKED BY: Marc Simmel	APPROVED BY: Joe Comerici
<small>TEMPLATE FILENAME: PRODUCT_SPEC[SIZE_A](V.1).DOC</small>				



PRELIMINARY HANDYLINK™ APPLICATION SPECIFICATION

6.1.2 Plug Connector Module

The plug connector module is intended to be used as a part of an assembly using either direct wire soldering (**45339**) or using an intermediary PCB (**45593**). Overmolding and/or clam shell style covers must be used to protect the wire connections and the appropriate service loops and wire strain reliefs must be incorporated in a cable assembly to prevent damage during use. Please refer to section 6.3 for further details about the over-molding process. If the connector module is used as a stand-alone component on a PCB, the mating interface must be adequately supported. Please refer to section 6.4.2 for further details concerning cradle design recommendations.

6.1.3 Cradle Connector

The cradle connector is designed to be fastened to the PCB with screws. See Sales Drawings for recommended screw size and positions. Please refer to section 6.4.2 for further details concerning cradle design recommendations.

<u>REVISION:</u> A	<u>ECR/ECN INFORMATION:</u> EC No: UCP2004-2588 DATE: 6/24/04	<u>TITLE:</u> APPLICATION SPECIFICATION HANDYLINK™/O CONNECTOR SYSTEM	<u>SHEET No.</u> 9 of 21
<u>DOCUMENT NUMBER:</u> AS-44828-001	<u>CREATED / REVISED BY:</u> T. Gregori/ M. Simmel	<u>CHECKED BY:</u> Marc Simmel	<u>APPROVED BY:</u> Joe Comerchi

TEMPLATE FILENAME: PRODUCT_SPEC[SIZE_A](V.1).DOC



PRELIMINARY HANDYLINK™ APPLICATION SPECIFICATION

6.2 Ingress Protection

Ingress protection, as described by IEC 60529, is a function of the customer's enclosure. The HandyLink™ Receptacle Connector has been designed to facilitate enclosure design when ingress protection is required. The interfaces between the metal and plastic components of the connector are sealed to discourage intrusion of dust and liquid through the connector into the enclosure. The customer is expected to design an appropriate seal around the periphery of the connector to adequately seal the finished enclosure. Contact Molex for additional information.

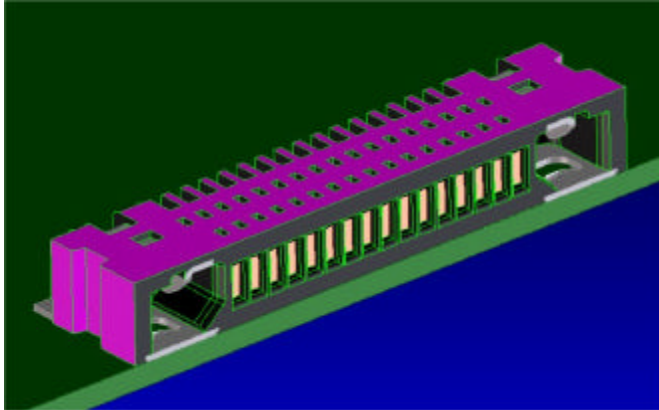

Gaskets may be applied to the top and sides, or front surfaces.

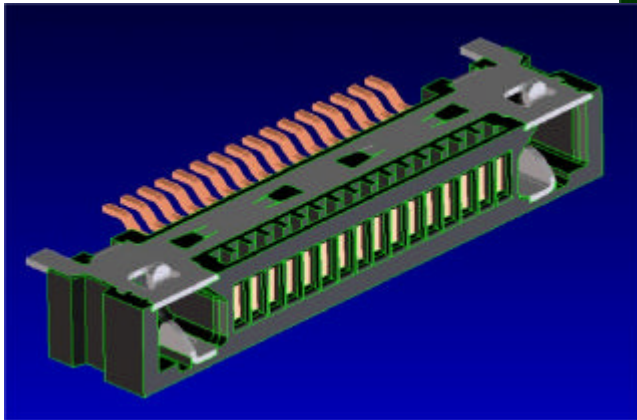
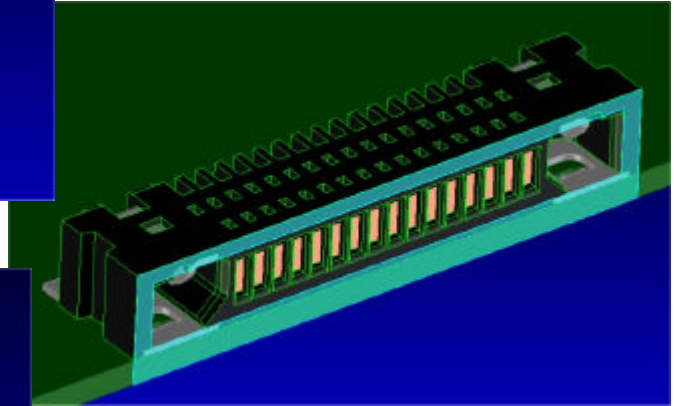

The bottom surface, once soldered, forms a continuous seal with the PCB

Figure 4. Sealing to achieve ingress protection with the receptacle connector

REVISION: A	ECR/ECN INFORMATION: EC No: UCP2004-2588 DATE: 6/24/04	TITLE: APPLICATION SPECIFICATION HANDYLINK™/O CONNECTOR SYSTEM		SHEET No. 10 of 21
DOCUMENT NUMBER: AS-44828-001		CREATED / REVISED BY: T. Gregori/ M. Simmel	CHECKED BY: Marc Simmel	APPROVED BY: Joe Comerchi
<small>TEMPLATE FILENAME: PRODUCT_SPEC[SIZE_A](V.1).DOC</small>				



PRELIMINARY HANDYLINK™ APPLICATION SPECIFICATION

6.3 Plug Cable Over-Molding

6.3.1 Wire Soldering

This section provides an outline of the recommended plug cable over-molding practices for the 45339 and 45593 plug connector modules. The 45339 connector (a 16-circuit wire termination version) is shown, below, prior to soldering. Please note the following features:

Latch soldertails (2 places) Wire soldertails (2 rows)

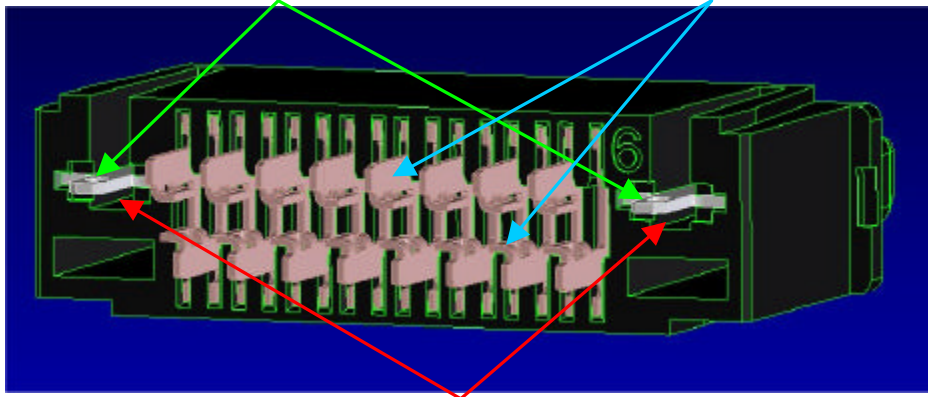

Cavities under the latches (2 places)

Figure 5. Soldertail side of the plug connector

Pre-tinned wires should be terminated to the appropriate solder tails working in sequence and one row at a time, taking care that the insulation does not become exposed more than 1mm from the end of the terminals. The completed assembly after soldering of the wires is shown below. Dressing of the wires should be avoided until after the soldering and encapsulation processes are complete.

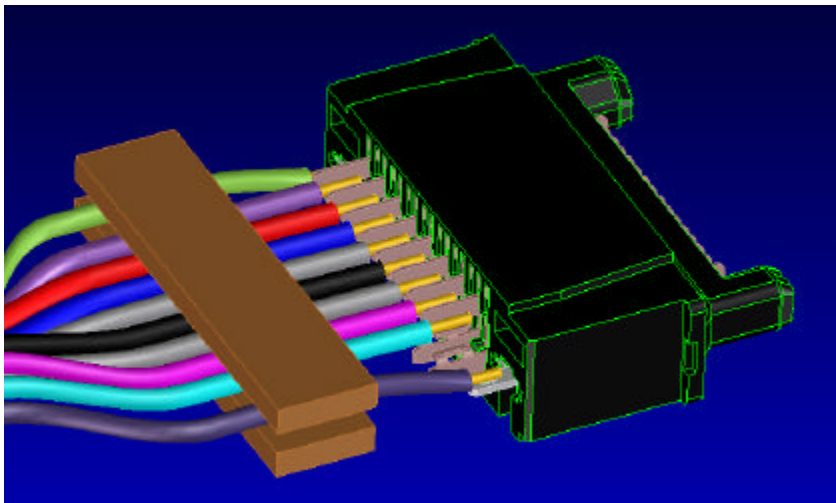

Figure 6.
Plug Soldering Set-Up

NOTE: The wire bundle must be properly supported or clamped as shown, during soldering and handling, to avoid dislodging terminals or latches from the housing prior to encapsulation, application of a strain relief, and the final over-mold.

REVISION: A	ECR/ECN INFORMATION: EC No: UCP2004-2588 DATE: 6/24/04	TITLE: APPLICATION SPECIFICATION HANDYLINK™/O CONNECTOR SYSTEM		SHEET No. 11 of 21
DOCUMENT NUMBER: AS-44828-001		CREATED / REVISED BY: T. Gregori/ M. Simmel	CHECKED BY: Marc Simmel	APPROVED BY: Joe Comerchi

TEMPLATE FILENAME: PRODUCT_SPEC[SIZE_A](V.1).DOC



PRELIMINARY HANDYLINK™ APPLICATION SPECIFICATION

6.3.2 Encapsulation

The next step after soldering is to pre-seal or encapsulate the back end of the connector and hold the wires in place using a silicone sealant or a low-pressure Macro-melt polyamide adhesive molding. The sealant will prevent accidental shorting between adjacent terminals and discourage intrusion of over-mold resin into the terminal and latch cavities. An illustration of the pre-seal coverage is shown below. Care must be taken to ensure that no encapsulant enters the terminal or latch cavities.

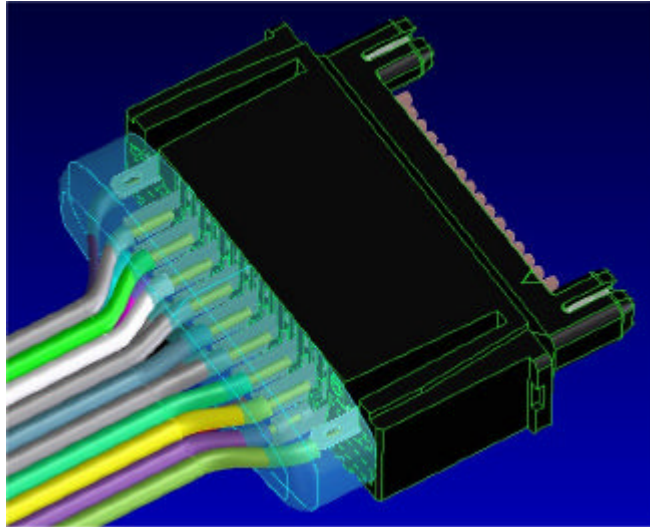

Figure 7.
Encapsulated plug
connector

An alternate method is to combine one or more molded 'covers' to block entire sections where void circuits are present, then use a pre-seal or encapsulant to hold the wires separate. This is illustrated below.

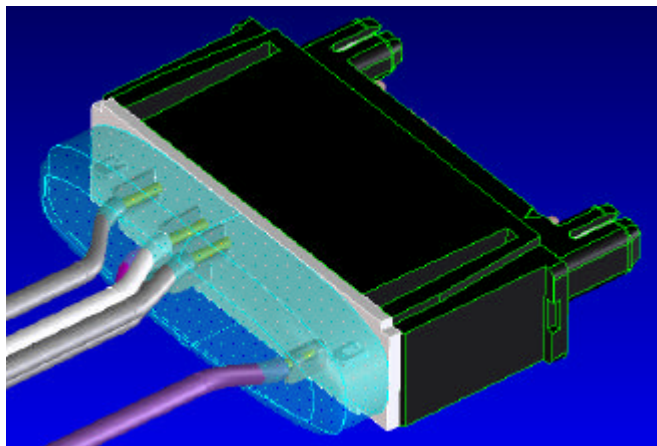

Figure 8.
Covered and
encapsulated plug
connector

NOTE: The sealant or cover should enclose the cavities under the latches, whether or not wires are soldered to the latches. Omission of this step would allow the final over-mold resin to extrude into cavities in the housing that could disable latch and terminal function.

REVISION: A	ECR/ECN INFORMATION: EC No: UCP2004-2588 DATE: 6/24/04	TITLE: APPLICATION SPECIFICATION HANDYLINK™/O CONNECTOR SYSTEM	SHEET No. 12 of 21
DOCUMENT NUMBER: AS-44828-001	CREATED / REVISED BY: T. Gregori/ M. Simmel	CHECKED BY: Marc Simmel	APPROVED BY: Joe Comerici

TEMPLATE FILENAME: PRODUCT_SPEC[SIZE_A](V.1).DOC



PRELIMINARY HANDYLINK™ APPLICATION SPECIFICATION

6.3.3 Strain Relief

Molex strongly recommends the use of a crimp barrel or ferrule over the wire bundle (including ground or drain wire) that also captures the cable jacket and tension member, if used. This will uniformly distribute mechanical loads through the wire bundle and provide mechanical support to the cable jacket and tension member.

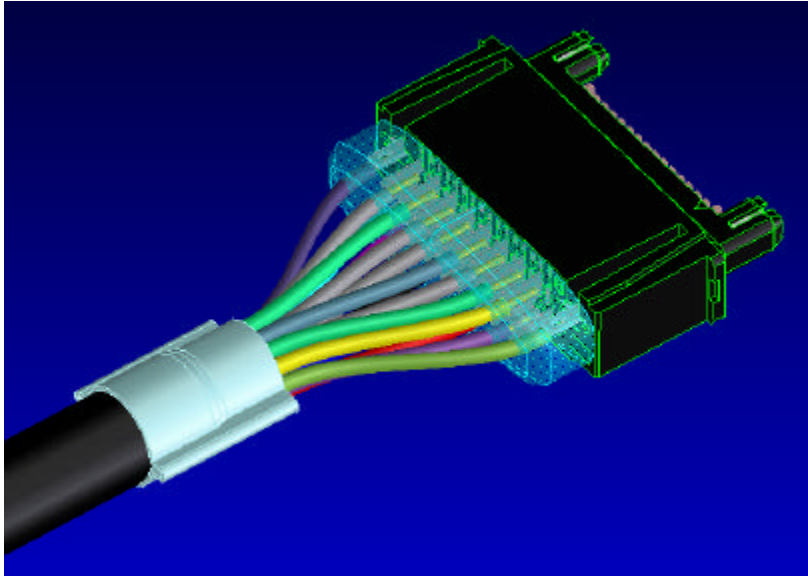

Figure 9.
Crimp barrel installed

6.3.4 Final Over-Molding

The final PVC over-mold may be injection-molded to completely cover the prepared cable assembly to provide an esthetically pleasing finished product. Please see Section 6.4.1 for a discussion of design best practices for the over-mold.

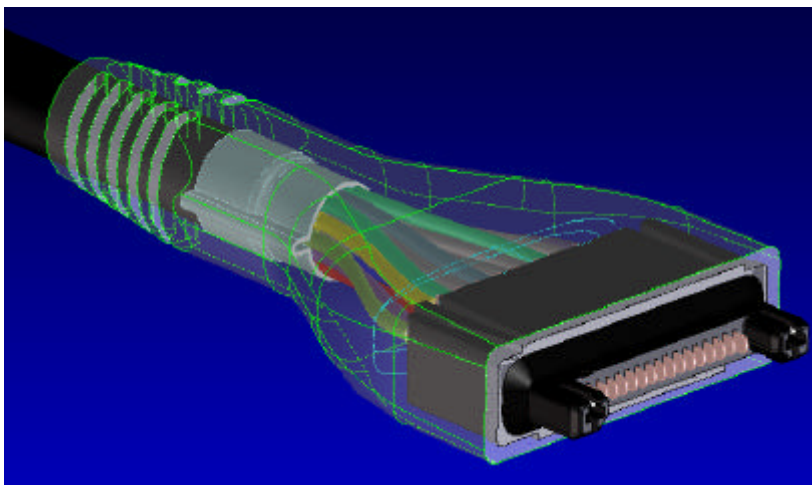

Figure 10.
Finished over-mold
(shown transparent)

REVISION: A	ECR/ECN INFORMATION: EC No: UCP2004-2588 DATE: 6/24/04	TITLE: APPLICATION SPECIFICATION HANDYLINK™/O CONNECTOR SYSTEM	SHEET No. 13 of 21
DOCUMENT NUMBER: AS-44828-001	CREATED / REVISED BY: T. Gregori/ M. Simmel	CHECKED BY: Marc Simmel	APPROVED BY: Joe Comerchi

TEMPLATE FILENAME: PRODUCT_SPEC[SIZE_A](V.1).DOC



PRELIMINARY HANDYLINK™ APPLICATION SPECIFICATION

6.4 Design Best Practices

The information provided so far in this document has been related to the basic usage conditions of the HandyLink™ connectors. The following sections contain important information and guidelines for design that apply to many situations that occur as a result of specific applications or industrial design constraints for the end-product accessories. In all cases, Molex advises that prototype assemblies be used as early in the design and development cycle as possible to assess the severity of the actual end-applications and identify the most appropriate solutions to any problems. Please contact Molex for technical assistance with design feasibility studies or design reviews.

6.4.1 Plug Over-Mold Designs

Supplemental guide features to align the connectors during mating or un-mating are strongly recommended if any of the following conditions are present:

- A great deal of curvature in the end product (such as that illustrated, below);
- The accessory cable is stiff or bent abruptly;
- The mass of the end-product itself is greater than 1000grams and is likely to experience more than 1g of acceleration during use or under vibration;
- The cable connection and disconnection cycles are numerous (more than 5000 cycles);
- There is significant risk of the end users pulling at connections in off-axis directions.

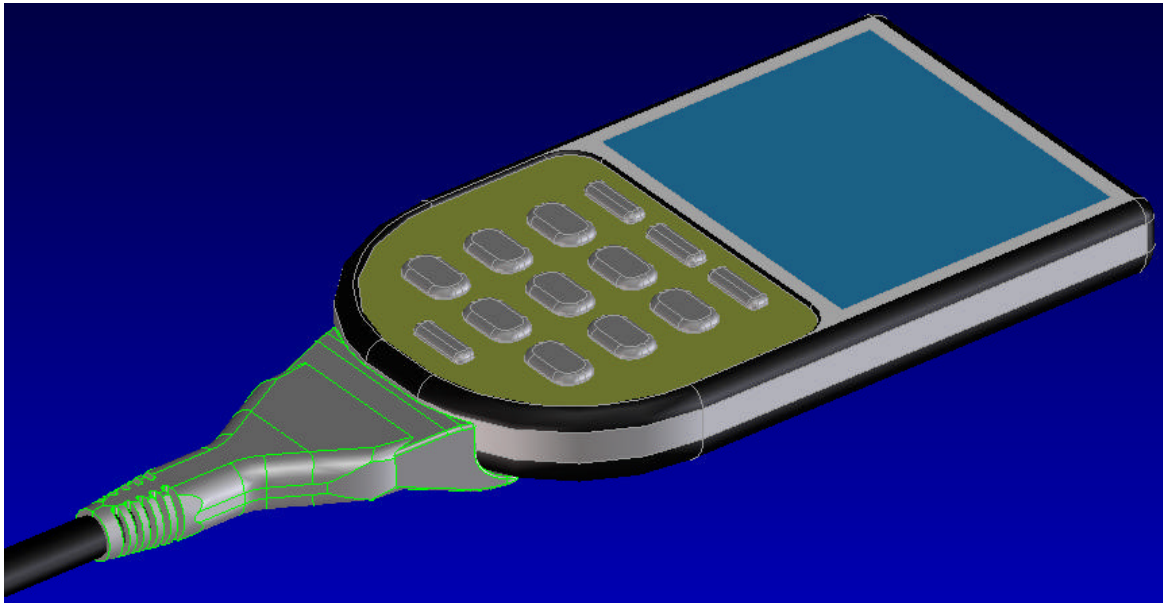

Figure 11. Example of an application with a great degree of curvature near the connector interface.

REVISION: A	ECR/ECN INFORMATION: EC No: UCP2004-2588 DATE: 6/24/04	TITLE: APPLICATION SPECIFICATION HANDYLINK™/O CONNECTOR SYSTEM		SHEET No. 14 of 21
DOCUMENT NUMBER: AS-44828-001	CREATED / REVISED BY: T. Gregori/ M. Simmel	CHECKED BY: Marc Simmel	APPROVED BY: Joe Comerchi	
<small>TEMPLATE FILENAME: PRODUCT_SPEC[SIZE_A](V.1).DOC</small>				



PRELIMINARY HANDYLINK™ APPLICATION SPECIFICATION

Supplemental guide features may be incorporated into or complement the over-mold design as illustrated in Figures 12 and 13:

o **Contouring with a Lip**

To provide mechanical support for torque out of the axial plane of the connectors, the over-mold must be designed to mimic the outer surfaces of the end product and include a lip such as illustrated below. NOTE: The axial clearance condition between the connectors noted in section 4.2 must be maintained.

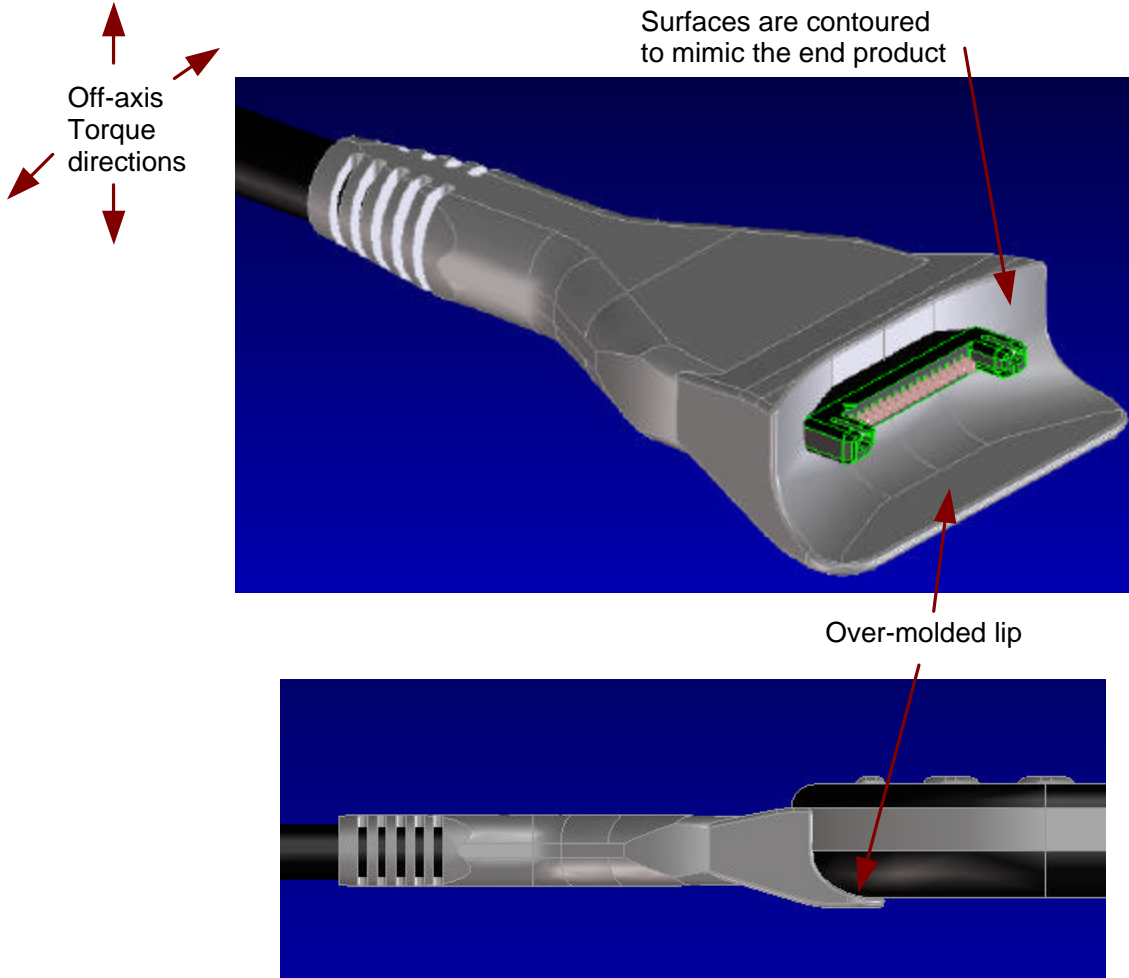

Figure 12. Example of an over-mold with contouring and a lip

This type of design will provide support for the end-user to hold the product by the connector or where a heavy or stiff accessory cable is used.

REVISION: A	ECR/ECN INFORMATION: EC No: UCP2004-2588 DATE: 6/24/04	TITLE: APPLICATION SPECIFICATION HANDYLINK™/O CONNECTOR SYSTEM		SHEET No. 15 of 21
DOCUMENT NUMBER: AS-44828-001		CREATED / REVISED BY: T. Gregori/ M. Simmel	CHECKED BY: Marc Simmel	APPROVED BY: Joe Comerchi
<small>TEMPLATE FILENAME: PRODUCT_SPEC[SIZE_A](V.1).DOC</small>				



PRELIMINARY HANDYLINK™ APPLICATION SPECIFICATION

○ **Supplemental Latching and Alignment Posts**

Where the mass of the end product is greater than 1000 grams and is subject to sudden accelerations or strong vibrations during use, a cup-style receptacle needs to be considered to adequately protect the connection interface. The cup-style receptacle should incorporate separate external latching features and supplemental alignment posts similar to those illustrated below. NOTE: The cup-style receptacle's dimensions must restrict angular misalignment, when mated, to within the limits specified in Section 4.2.

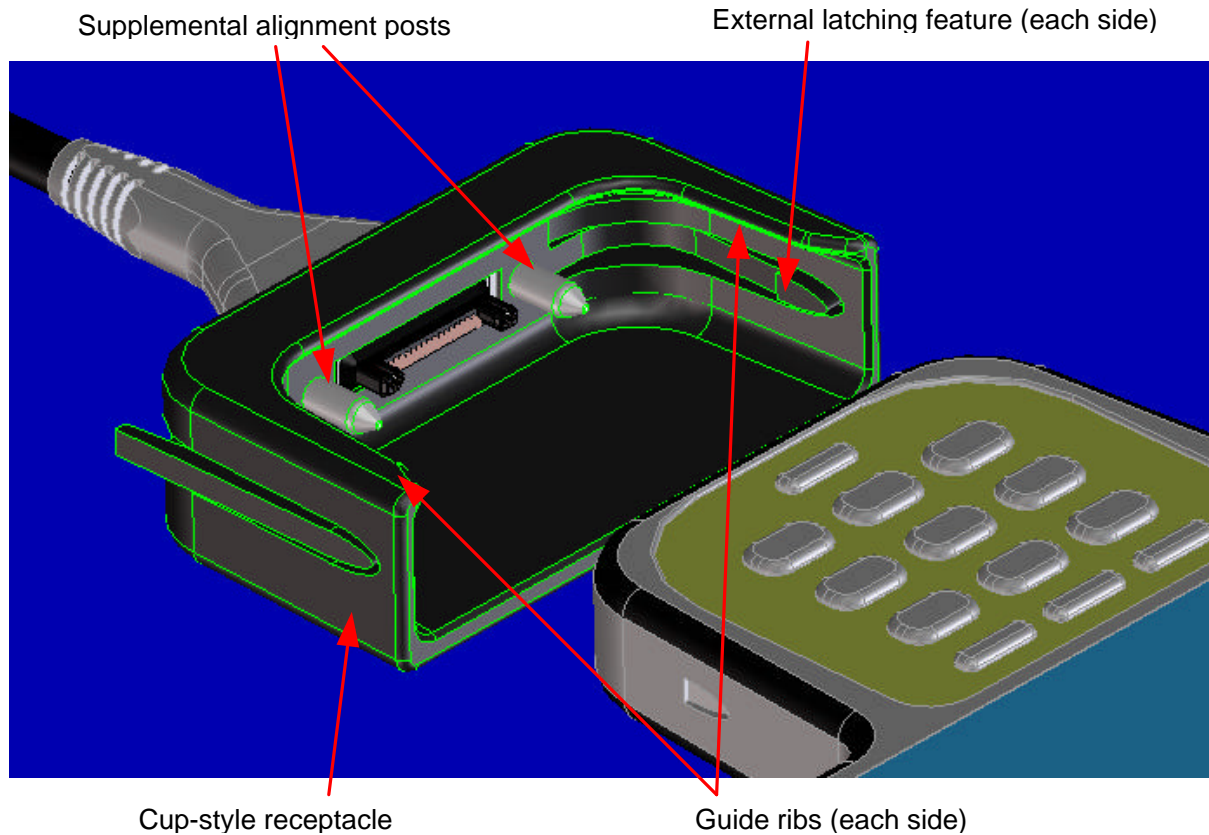

Figure 13. Use of a cup-style receptacle for added support and alignment

Supplemental alignment posts must be longer than the protrusion of the plug connector posts from the base surface of the cup-style receptacle. Further, the alignment posts' centerlines must lie in the same plane as the centerlines of the plug connector posts to provide the greatest benefits. Guide ribs are necessary to prevent front-to back rocking motion as the device is loaded into the cup-style receptacle.

NOTE: The fastening of the cup-style receptacle to the over-molded plug must be kept tight to avoid misalignment. If this is not achieved, excessive wear between the connector housings and/or electrical discontinuities may occur.

REVISION: A	ECR/ECN INFORMATION: EC No: UCP2004-2588 DATE: 6/24/04	TITLE: APPLICATION SPECIFICATION HANDYLINK™/O CONNECTOR SYSTEM		SHEET No. 16 of 21
DOCUMENT NUMBER: AS-44828-001		CREATED / REVISED BY: T. Gregori/ M. Simmel	CHECKED BY: Marc Simmel	APPROVED BY: Joe Comerchi
TEMPLATE FILENAME: PRODUCT_SPEC[SIZE_A](V.1).DOC				



PRELIMINARY HANDYLINK™ APPLICATION SPECIFICATION

6.4.2 Cradle Designs

○ Cup Style

The cup or holster style of cradle provides the greatest degree of alignment between mating connectors. Where the end product mass is greater than 1000 grams the use of supplemental alignment posts is recommended. The alignment posts' effective length (not including any lead-in taper) must be longer than the protrusion of the connector posts from the base surface of the cup-style receptacle. Further, the alignment posts' centerlines must lie in the same plane as the centerlines of the plug connector posts to provide the greatest benefits. Guide ribs are necessary on each side to limit front-to-back rocking motion as the device is loaded into the cup-style cradle.

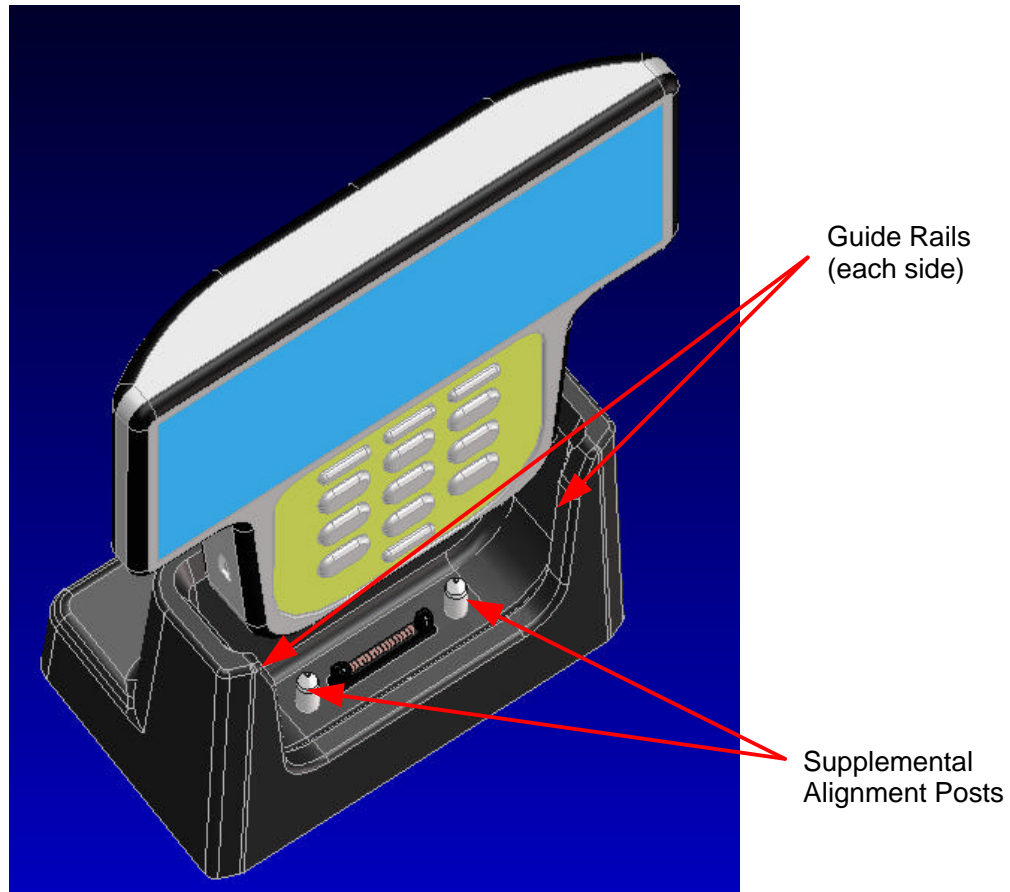

Figure 14. Cup-Style Cradle Features

NOTE: For details about mounting the connectors to the PCB and the use of fasteners, please refer to the applicable Sales Drawings.

REVISION: A	ECR/ECN INFORMATION: EC No: UCP2004-2588 DATE: 6/24/04	TITLE: APPLICATION SPECIFICATION HANDYLINK™/O CONNECTOR SYSTEM		SHEET No. 17 of 21
DOCUMENT NUMBER: AS-44828-001		CREATED / REVISED BY: T. Gregori/ M. Simmel	CHECKED BY: Marc Simmel	APPROVED BY: Joe Comerçi
<small>TEMPLATE FILENAME: PRODUCT_SPEC[SIZE_A](V.1).DOC</small>				



PRELIMINARY HANDYLINK™ APPLICATION SPECIFICATION

Figures 15 and 16 show orthogonal views of showing differences in the position and size of the openings in the cradle casing, and the PCB location for the 45560 and 45593 connectors. Figure 17 shows a chamfer detail applicable to 45593.

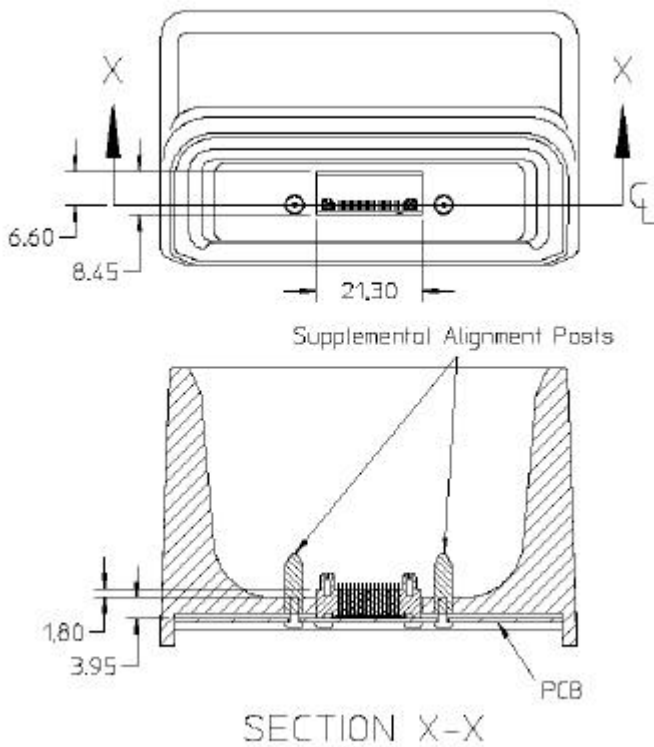

Figure 15. Cradle Detail (45560)
(units: mm)

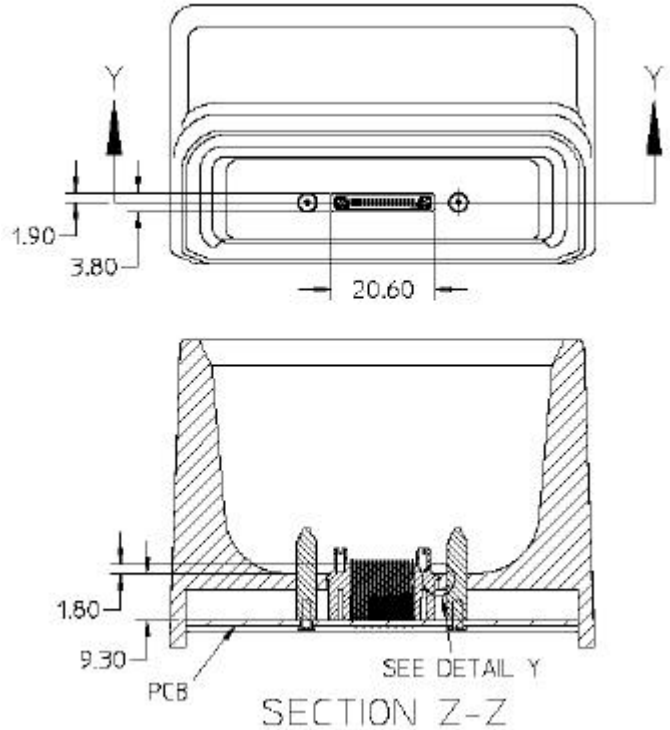

Figure 16. Cradle Detail (45593)
(units: mm)

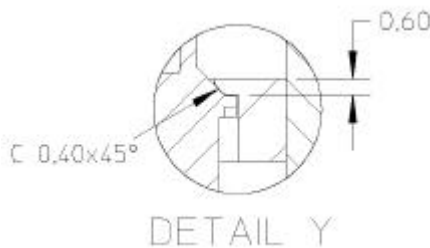

Figure 17. Detail from Figure 16.
(units: mm)

REVISION: A	ECR/ECN INFORMATION: EC No: UCP2004-2588 DATE: 6/24/04	TITLE: APPLICATION SPECIFICATION HANDYLINK™/O CONNECTOR SYSTEM		SHEET No. 18 of 21
DOCUMENT NUMBER: AS-44828-001	CREATED / REVISED BY: T. Gregori/ M. Simmel	CHECKED BY: Marc Simmel	APPROVED BY: Joe Comerchi	

TEMPLATE FILENAME: PRODUCT_SPEC[SIZE_A](V.1).DOC



PRELIMINARY HANDYLINK™ APPLICATION SPECIFICATION

○ **Shelf Style**

To achieve a 'rocking' disconnection for the end product from the cradle, a shelf style cradle design may be used under the following conditions:

- No supplemental guide posts may be used;
- The end product may not have more than 1000 grams mass;
- Side-to-side motion must be limited using end-walls or a guide rail;
- The vibration conditions of the end application must be limited.

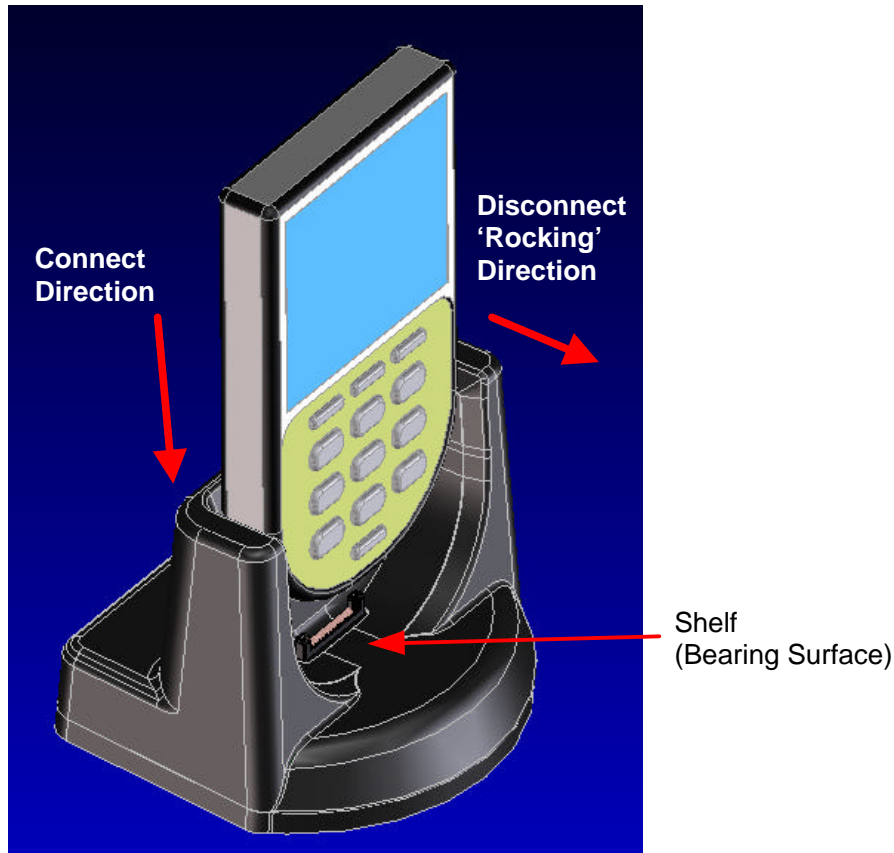

Figure 18. Shelf-Style Cradle Features

NOTE: For details about mounting the connectors to the PCB and the use of fasteners, please refer to the applicable Sales Drawings.

REVISION: A	ECR/ECN INFORMATION: EC No: UCP2004-2588 DATE: 6/24/04	TITLE: APPLICATION SPECIFICATION HANDYLINK™/O CONNECTOR SYSTEM		SHEET No. 19 of 21
DOCUMENT NUMBER: AS-44828-001	CREATED / REVISED BY: T. Gregori/ M. Simmel	CHECKED BY: Marc Simmel	APPROVED BY: Joe Comerchi	
TEMPLATE FILENAME: PRODUCT_SPEC[SIZE_A](V.1).DOC				



PRELIMINARY HANDYLINK™ APPLICATION SPECIFICATION

In addition to the differences in the position and size of the openings in the cradle casing,

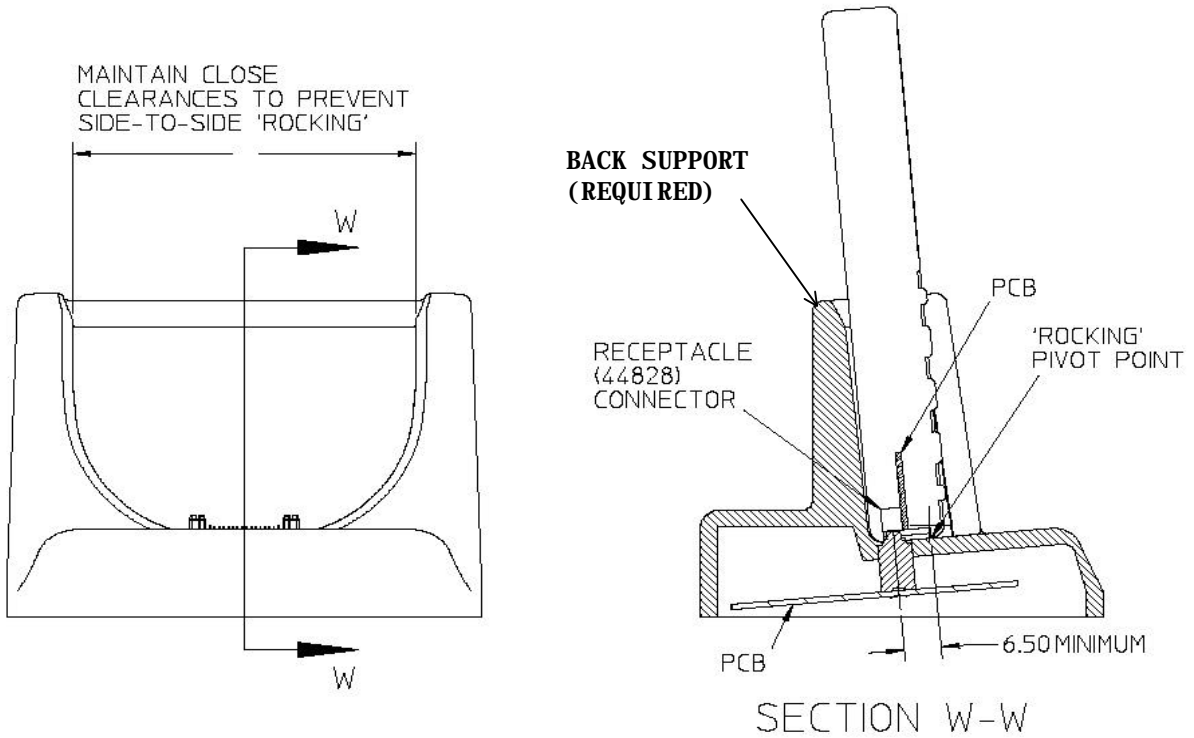

the PCB location for the 45560 and 45593 connectors, and the chamfer detail applicable to 45593 that is shown in Figures 15 thru 17. Figures 19 through 21 illustrate details necessary to achieve a good 'rocking' design.

Figure 19. Front View of Shelf-Style Cradle

Figure 20. Section View of Shelf-Style Cradle (units: mm)

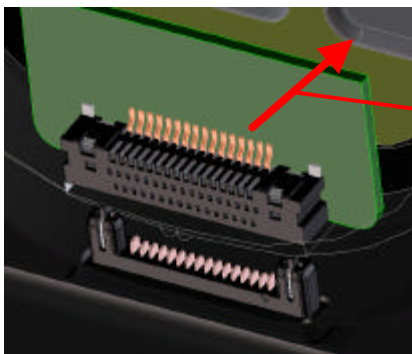

Rocking Direction

NOTE: Orientation of the receptacle connector and the plug or cradle connector must correspond to that shown for good operation of a 'rocking' design.

Figure 21. Connector Orientation

REVISION: A	ECR/ECN INFORMATION: EC No: UCP2004-2588 DATE: 6/24/04	TITLE: APPLICATION SPECIFICATION HANDYLINK™/O CONNECTOR SYSTEM	SHEET No. 20 of 21
DOCUMENT NUMBER: AS-44828-001	CREATED / REVISED BY: T. Gregori/ M. Simmel	CHECKED BY: Marc Simmel	APPROVED BY: Joe Comerici

TEMPLATE FILENAME: PRODUCT_SPEC[SIZE_A](V.1).DOC



PRELIMINARY HANDYLINK™ APPLICATION SPECIFICATION

7.0 Electrical Recommendations

7.1 Power Considerations

Please see the Product Specification, PS-44828-001, for the nominal electrical specifications. For applications where the sustained electrical power usage requirements exceed the limits stated in the product specification, the use of multiple circuits is suggested.

When the end-application is likely to encounter salt spray conditions, potential differences exceeding 4VDC should be separated by more than one terminal position (i.e. 1.6mm or more) to avoid galvanic corrosion between circuits.

7.2 High Speed Signal Transmission

Testing has shown that under the USB 2.0 Specification environment for connector components and cable assemblies (200 and 500 picosecond rise times), the HandyLink connectors perform within specification for both differential and common-mode impedance.

Full compliance testing on finished cable assemblies will have to be undertaken to verify the performance level of the finished product.

Contact Molex for further assistance regarding high speed signal transmission applications.

REVISION: A	ECR/ECN INFORMATION: EC No: UCP2004-2588 DATE: 6/24/04	TITLE: APPLICATION SPECIFICATION HANDYLINK™/O CONNECTOR SYSTEM	SHEET No. 21 of 21
DOCUMENT NUMBER: AS-44828-001	CREATED / REVISED BY: T. Gregori/ M. Simmel	CHECKED BY: Marc Simmel	APPROVED BY: Joe Comerchi

TEMPLATE FILENAME: PRODUCT_SPEC[SIZE_A](V.1).DOC