

THIS DRAWING IS UNPUBLISHED. ALL INFORMATION HEREIN IS UNCLASSIFIED. ALL INFORMATION SUBJECT TO THE ELECTRONICS CORPORATION. ALL INFORMATION SUBJECT TO THE ELECTRONICS CORPORATION.

REV	DATE	DESCRIPTION	BY	CHKD
00				
01		REV E02-10-02078		

- △ DIMENSIONS ARE MAXIMUM UNLESS OTHERWISE SPECIFIED.
- △ FOUR 10-32 X 15.88 [625] LONG STAINLESS STEEL CROSS RECESSED ROUND HEAD SCREWS AND FOUR #10 STAINLESS STEEL EXTERNAL TOOTH LOCKWASHERS FOR MOUNTING PANEL ASSEMBLY SHIPPED LOOSE, NOT SHOWN.
- △ MATERIAL: PANEL- BLACK ANODIZED ALUMINUM
WIRING BLOCK- POLYCARBONATE, IVORY.
PUSH RIVET- NYLON
- 4. PANEL HAS TWO STAINLESS STEEL GROUNDING STUDS ON REAR OF PANEL FOR OPTIONAL GROUNDING LUGS.
- 5. LACING STRIPS MARKED BLACK EVERY FIFTH PAIR.

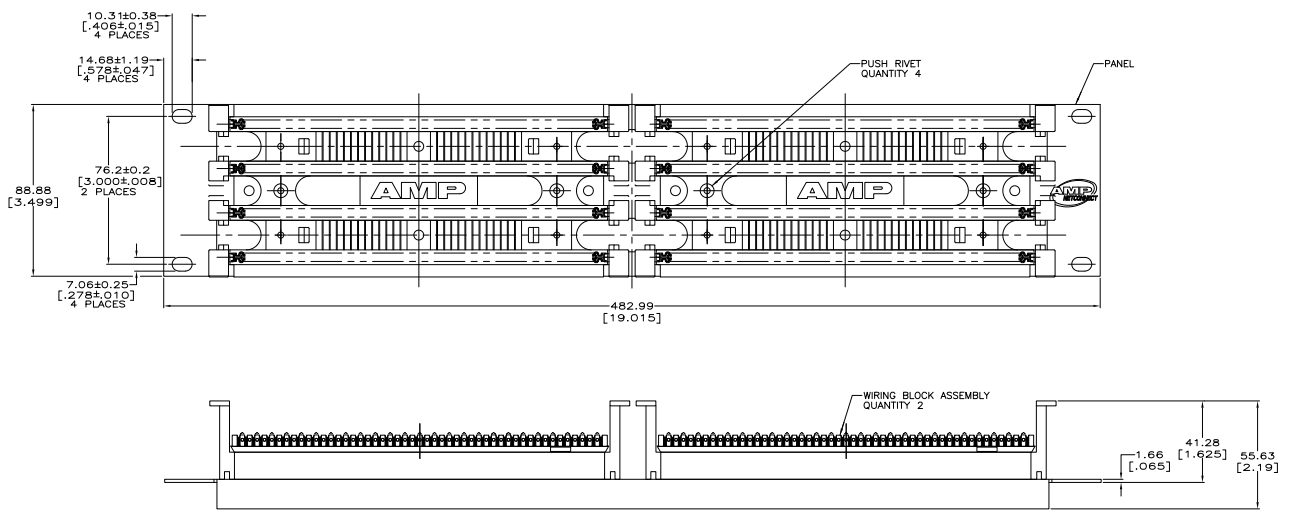

THIS DRAWING IS A CONTROLLED DOCUMENT.		REV. 00	DATE	558637-1
DRAWN BY: [Signature]		DATE	17NOV2010	REV. 00
CHECKED BY: [Signature]		DATE		
APPROVED BY: [Signature]		DATE		
PART NO. 558637-1		Teco Electronics Corporation Harrisburg, PA 17105-3608		
PROJECT NAME: PANEL ASSEMBLY, XCONN		DRAWING NO. 00779		
REV. 00		DATE 10/20/07		
CUSTOMER DRAWING		REV. 00		