

REV	DATE	DESCRIPTION	BY	CHK	APP
A	0210-0510-96		DMUG98	DS	DW
B	REV-ECD-06-017000		17.JAL06	LH	SH

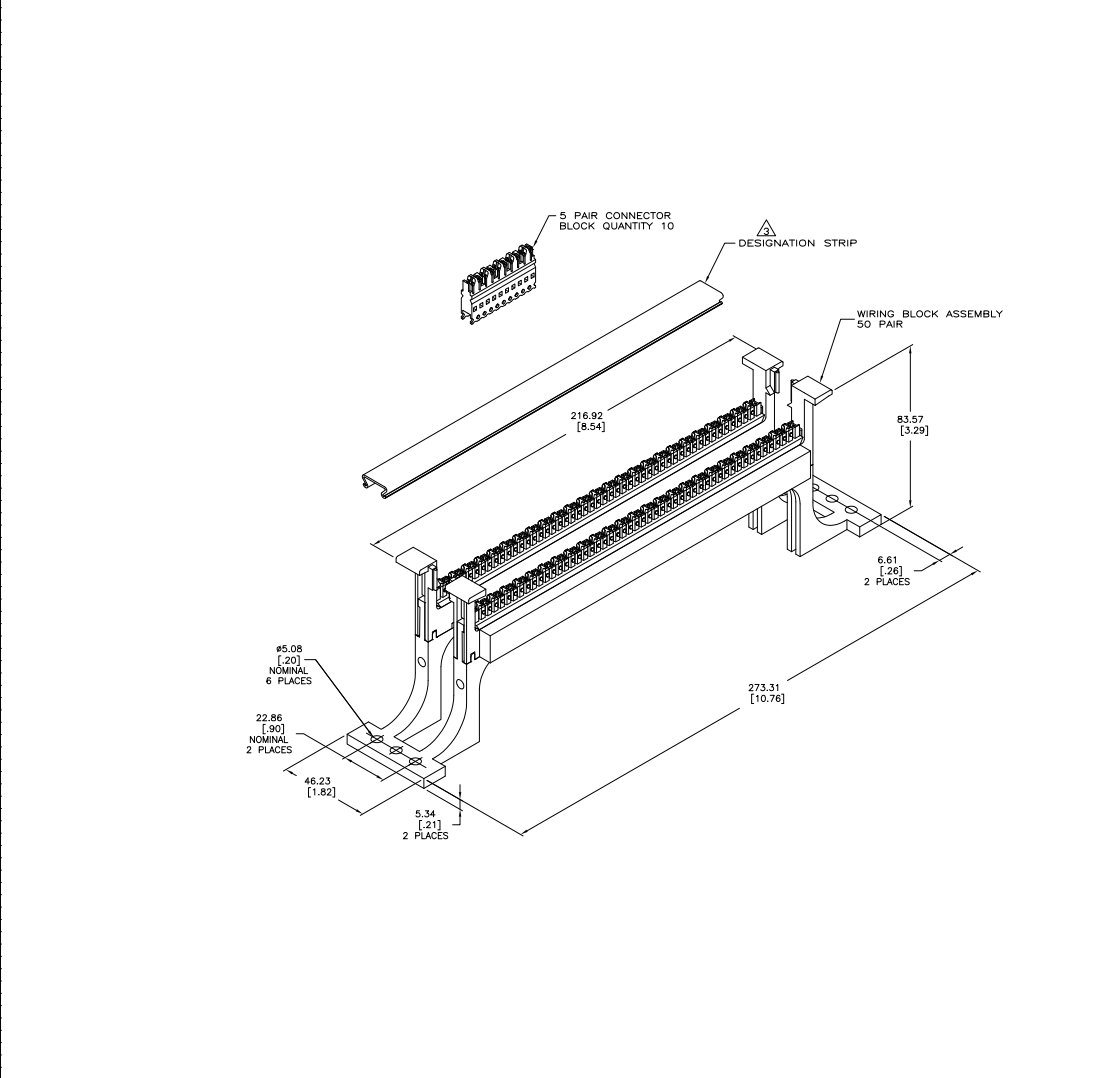

- △ DIMENSIONS ARE MAXIMUM UNLESS OTHERWISE SPECIFIED.
- △ MATERIAL: WIRING BLOCK ASSEMBLY AND CONNECTOR BLOCK— POLYCARBONATE MOLDING COMPOUND, FLAME RETARDANT, IVORY.
DESIGNATION STRIP— RIGID PVC, CLEAR.
TERMINALS— PHOSPHOR BRONZE PLATED WITH 3.81 [0.00150] MINIMUM BRIGHT MATTE-TIN OVER 1.27μm [0.00050] MINIMUM NICKEL UNDERPLATE.
- △ WHITE, DESIGNATION STRIP LABEL NOT SHOWN.
- 4. PACKAGE ONE KIT PER POLYBAG.
- △ LACING STRIPS MARKED BLACK EVERY FIFTH PAIR.

569434-1
PART NO.

THIS DRAWING IS A CONTROLLED DOCUMENT.		DATE	BY	CHK	APP
DRAWING NO. 569434-1		11-01-02	DMUG98	DS	DW
DESCRIPTION		110 CROSS CONNECT KIT, 50 PAIR, WITH LEGS, 5 PAIR CONNECTOR BLOCK			
CUSTOMER DRAWING		DATE	BY	CHK	APP
		00779	DMUG98	DS	DW