

DATE	REV	EON	APP'D. BY
1/31/06	A2	7461	JM
2-23-06	A3	7515	JM

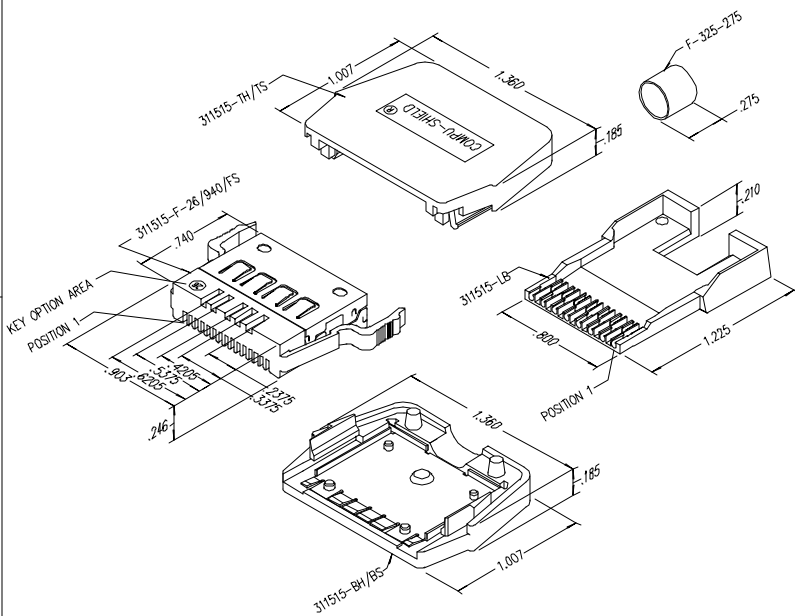

NOTES:

1. PLUG MATERIALS:
TOP/BOTTOM HOUSING: PC UL94 V-0 COLOR: BLACK
FRONT PLASTIC: PC UL94 V-0 COLOR: CLEAR
LOAD BAR: PC UL94 V-0 COLOR: CLEAR
CONTACTS/SHIELD: COPPER ALLOY
SHIELD/FERRULE PLATING: TIN
CONTACT PLATING: SELECTIVE GOLD IN CONTACT AREA
SEE CHART FOR PART NUMBER
2. CONTACTS TERMINATE SOLID OR STRANDED CONDUCTORS UP TO .042" OUTSIDE DIAMETER OF INSULATION
3. TOLERANCES COMPLY WITH F.C.C. DIMENSION REQUIREMENTS.
4. HOUSING WILL ACCEPT CABLE UP TO .290" OUTSIDE DIAMETER OF JACKET
5. FOR PRODUCT SPECIFICATIONS SEE PRO26-01
6. TERMINATED PLUG HEIGHT .234±.002

50 MICRO-INCHES [1.27um]	SS-311515-26
CONTACT PLATING IN MATING AREA	PART NUMBER

THIRD ANGLE PROJECTION

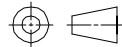

DO NOT SCALE DRAWING
DRAWING IS SUBJECT TO CHANGE WITHOUT NOTICE
DIMENSIONS: INCHES [METRIC]
UNLESS OTHERWISE SPECIFIED
TOLERANCES ARE ±.005 [0.13]
ANGLES ARE ± 1°

SHEET NO. 1 OF 1

Bel Stewart Connector

11118 Susquehanna Trail South
Glen Rock, PA 17327-9199
(717) 235-7512 Fax: (717) 235-7954 <http://www.stewartconnector.com>

TITLE: 15X15 COMPU-SHIELD PLUG FINAL ASSEMBLY

DRN BY:	KRL	DATE:	1/31/06
APP'D BY:	JM	DATE:	2-1-06
DWG NO.:	CT310009	REV:	A3

AutoCAD

REV. 6/5/05

