

DATE	REV	EON	APP'D. BY
1/31/06	B1	7461	JM
2-23-06	B2	7515	JM

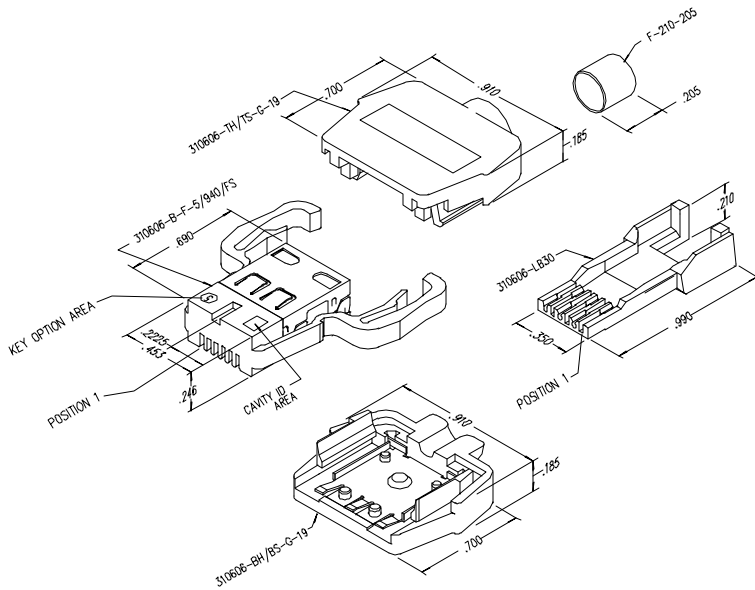

**NOTES:**

1. PLUG MATERIALS:  
TOP/BOTTOM HOUSING: PC UL94 V-0 COLOR: GREY  
FRONT PLASTIC: PC UL94 V-0 COLOR: CLEAR  
LOAD BAR: PC UL94 V-0 COLOR: BLUE  
CONTACTS/SHELD: COPPER ALLOY  
SHELD/FERRULE PLATING: TIN  
CONTACT PLATING: SELECTIVE GOLD IN CONTACT AREA  
SEE CHART FOR PART NUMBER
2. CONTACTS TERMINATE SOLID OR STRANDED CONDUCTORS UP TO .028" OUTSIDE DIAMETER OF INSULATION
3. TOLERANCES COMPLY WITH F.C.C. DIMENSION REQUIREMENTS.
4. HOUSING WILL ACCEPT CABLE UP TO .220" OUTSIDE DIAMETER OF JACKET
5. FOR PRODUCT SPECIFICATIONS SEE PRO26-01
6. TERMINATED PLUG HEIGHT: 234±.002

50 MICRO-INCHES [1.27um]	SS-310606-5-0010
CONTACT PLATING IN MATING AREA	PART NUMBER

THIRD ANGLE PROJECTION

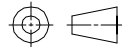

DO NOT SCALE DRAWING  
DRAWING IS SUBJECT TO CHANGE WITHOUT NOTICE  
DIMENSIONS: INCHES [METRIC]  
UNLESS OTHERWISE SPECIFIED  
TOLERANCES ARE ±.005 [0.13]  
ANGLES ARE ± 1°

SHEET NO. 1 OF 1



## Bel Stewart Connector

11118 Susquehanna Trail South  
Glen Rock, PA 17327-9199  
(717) 235-7512 Fax: (717) 235-7954 <http://www.stewartconnector.com>

TITLE: 6X6 COMPU-SHIELD PLUG FINAL ASSEMBLY

DRN BY:	KRL	DATE:	1/31/06
APP'D BY:	JM	DATE:	2-1-06
DWG NO.:	CT310026	REV.:	B2

AutoCAD

REV. 6/15/05