

2

1

DATE	REV	ECN	APP'D. BY
1-16-06	B1	7440	JM
1-29-09	B2	8642	TA

B

B

A

A

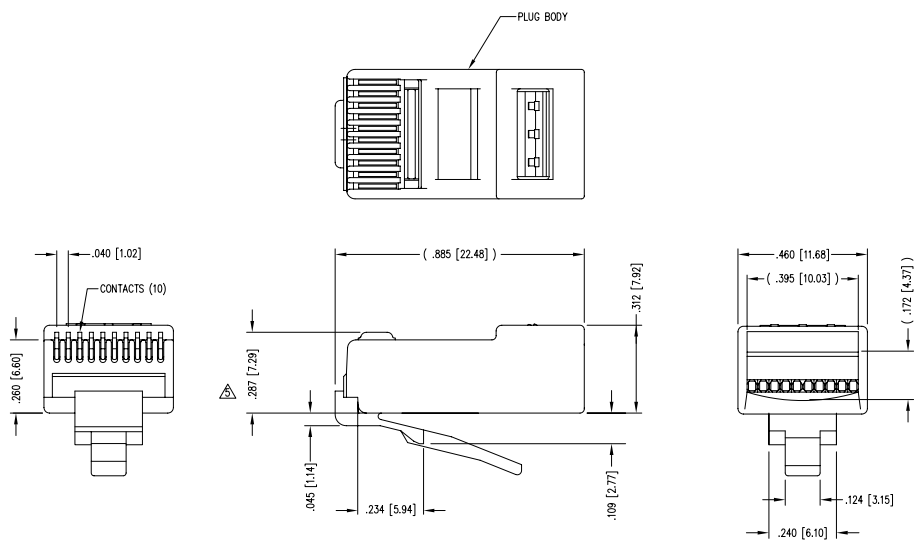

NOTES:

- 1- MATERIALS:
 PLUG BODY: POLYCARBONATE, UL 94-V0, CLEAR
 CONTACTS: PHOSPHOR BRONZE, SELECTIVE GOLD PLATING
 - 2- CONTACTS TERMINATE STRANDED CONDUCTORS UP TO .037 [0.94] OUTSIDE DIAMETER OF INSULATION.
 - 3- FOR PRODUCT SPECIFICATION SEE PRO26-01.
 - 4- TOLERANCES COMPLY WITH F.C.C. DIMENSION REQUIREMENTS.
- △ TERMINATED PLUG HEIGHT: .237 [6.02] ± .005 [0.13]

BULK	50 MICRO-INCHES [1.27um]	937-SP-301010R
PACKAGE	CONTACT PLATING IN MATING AREA	PART NUMBER

THIRD ANGLE PROJECTION

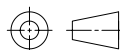

DO NOT SCALE DRAWING

DRAWING IS SUBJECT TO CHANGE WITHOUT NOTICE

DIMENSIONS: INCHES [METRIC]

UNLESS OTHERWISE SPECIFIED TOLERANCES ARE ±.005 [0.13] ANGLES ARE ± 1°

SHEET NO. 1 OF 1



Bel Stewart Connector

11118 Susquehanna Trail South
 Glen Rock, PA 17327-9199
 (717) 235-7512 Fax: (717) 235-7954 <http://www.stewartconnector.com>

TITLE: TEN CONDUCTOR/TEN POSITION LINE CORD MODULE WITH RADIAL BACK; COLOR: CLEAR

THIS DRAWING AND THE SUBJECT MATTER SHOWN THEREON ARE CONFIDENTIAL AND THE PROPRIETARY PROPERTY OF STEWART CONNECTOR ("SCS") AND SHALL NOT BE REPRODUCED, COPIED OR USED IN ANY MANNER WITHOUT PRIOR WRITTEN CONSENT OF "SCS". THE SUBJECT MATTER MAY BE PATENTED OR A PATENT MAY BE PENDING. © SCS

DRN BY: TRM DATE: 1-24-03

APP'D BY: RGC DATE: 1-28-03

DWG NO. CT300070 REV. B2

AutoCAD

2

1

REV. 10/29/02