

4

3

2

1

THIS DRAWING IS UNPUBLISHED. RELEASED FOR PUBLICATION. ALL RIGHTS RESERVED.

LOC	DIST	REVISIONS				
HM	00	F	LR	DATE	BY	APPD
		Y1		REVISED PER ECO-11-005033	21MAR11	RK HMR

- 1 MATERIAL: HOUSING-POLYCARBONATE,CLEAR. TERMINAL-0.36[.014] THICK PHOSPHOR BRONZE PLATED WITH 1.27µm[.000050] THICK GOLD IN LOCALIZED GOLD PLATE AREA, GOLD FLASH OVER THE REMAINDER, OVER 2.54µm[.000100] THICK NICKEL UNDERPLATE.
- 2 DIMENSIONS ARE MAXIMUM UNLESS OTHERWISE SPECIFIED.
- 3. PLUG WILL ACCEPT 0.74-0.99[.029-.039] DIAMETER STRANDED WIRE, 26 OR 28 AWG, WITH A 5.34[.210] DIAMETER MAXIMUM JACKET.
- 4 TERMINATED DIMENSION 6.15[.242] MAXIMUM.
- 5 10 ASSEMBLIES PER PACKAGE
- 6 10,000 ASSEMBLIES PER PACKAGE.
- 7 500 ASSEMBLIES PER PACKAGE.
- 8 100 ASSEMBLIES PER PACKAGE.
- 9 25 ASSEMBLIES PER PACKAGE.
- 10 SEE RESTRICTED CUSTOMER DRAWING 5-554169-5.
- 11 100 ASSEMBLIES PER PACKAGE.

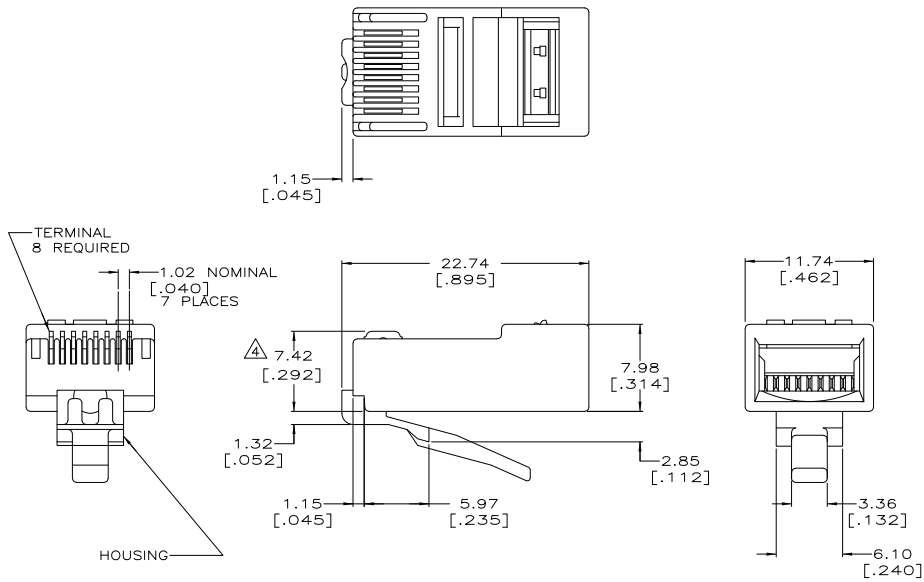

SUPERSEDED BY 5-554169-4	△	6-554169-5
SUPERSEDED BY 5-554169-4	△	6-554169-3
	△	5-554169-4
	△	5-554169-3
	△	5-554169-2
	△	5-554169-1
PACKAGED		PART NO

THIS DRAWING IS A CONTROLLED DOCUMENT.		DRW	YTP/MTA	8-30-93
DIMENSIONS: mm [INCHES]		CHK	C. WHITE	9-15-93
TOLERANCES UNLESS OTHERWISE SPECIFIED:		APPD	J. LONEY	9-20-93
0 PLG ± .010		NAME		
1 PLG ± .010		108-1163		
2 PLG ± .010		APPLICATION SPEC		
3 PLG ± .010		114-6016		
4 PLG ± .010		SIZE CASE CODE DRAWING NO		
ANGLES ± .010		A2 00779 C-554169		
MATERIAL - △		RESTRICTED TO		
FINISH - △		CUSTOMER DRAWING		
		SCALE 4:1 SHEET 1 of 1 REV Y1		

1471-9 (3/11)

554169

A