



# RJ45 Integrated Connector

10/100 Base-TX, Single Port, Through Hole

MODEL NUMBER  
**TIC-L001-11**

- Meets IEEE 802.3 and ANSI X3.263
- Operating temperature: 0°C to +85°C
- Storage Temperature: 0°C to +85°C

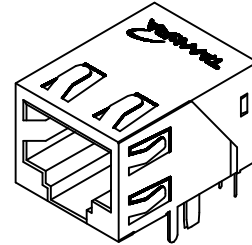

Electrical Specification From 0°C to +85°C								
Insertion Loss (dB Max)	Return Loss (dB Min)			CMRR (dB Min)	OCL ( $\mu$ H Min)	Hipot (Vrms)	Impedance ( $\Omega$ )	Crosstalk (dB Min)
	1-100 MHz	1-30 MHz	60 MHz					
-1	-18	-16	-12	-35	350	1500	190	-38

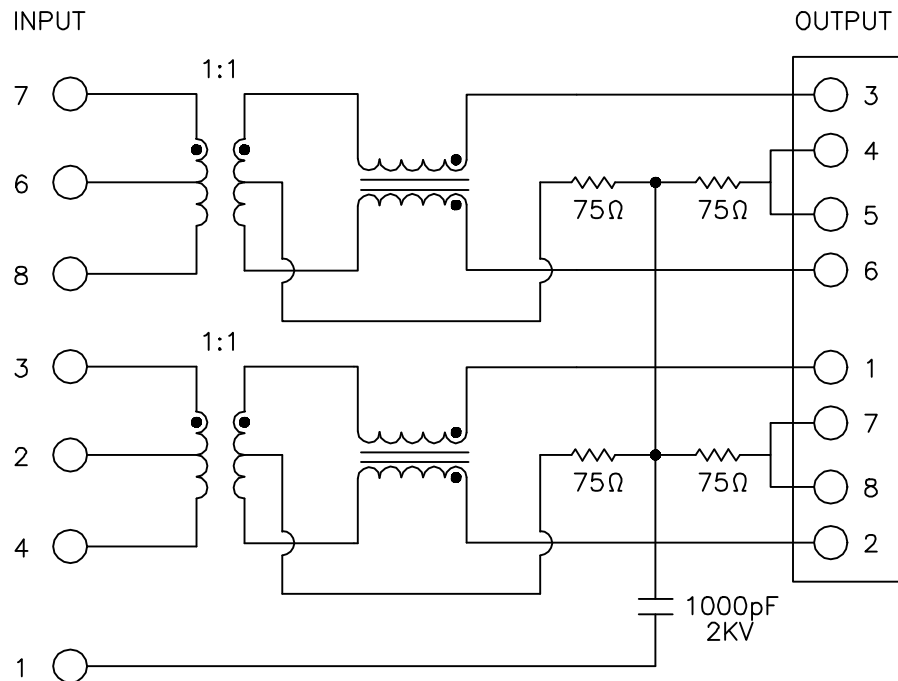

PREPARED BY:

D. Rund

ENGINEER:

L. Le

QUALITY CONTROL:

D. Kelley

APPROVED:

J. Coleman

DWG CONTROL NO.  
P-A1-12906  
ACAD\TTC\A1129061.DWG

REV  
**PRE**

RJ45  
INTEGRATED CONNECTOR

**TAMURA CORPORATION OF AMERICA**  
43352 BUSINESS PARK DRIVE, TEMECULA, CA. 92590-6624  
(909) 699-1270 FAX 9096769482

**TIC-L001-11**  
MODEL SPECIFICATION

DIM: mm(in) SCL: NONE SH: 1 OF 2

PROPRIETARY NOTICE: THIS DRAWING PRINT OR DOCUMENT AND SUBJECT MATTER DISCLOSED HEREIN ARE PROPRIETARY ITEMS TO WHICH TAMURA RETAINS THE EXCLUSIVE RIGHT OF DISSEMINATION, REPRODUCTION, MANUFACTURE AND SALE. THIS DRAWING, PRINT OR DOCUMENT IS SUBMITTED IN CONFIDENCE FOR CONSIDERATION BY THE RECIPIENT ALONE UNLESS PERMISSION FOR FURTHER DISCLOSURE IS EXPRESSLY GRANTED IN WRITING.



# RJ45 Integrated Connector

10/100 Base-TX, Single Port, Through Hole

MODEL NUMBER  
**TIC-L001-11**

Mechanical Material Specification

Contact Material	Contact						Housing and Insert	Shell	
	Contact Finish							Front	Back
	Upper Contact			Lower Contact					
	Contact Area	Solder Tail	Under-plating	Contact Area	Solder Tail Area	Under-plating		0.25mm thick	0.20mm thick
Phosphor Bronze	Gold	Tin/Lead (9:1)	Nickel	Gold	Tin/Lead (9:1)	Nickel	Thermal-plastic Nylon 6T	Stainless SUS 304	Stainless SUS 304
0.35mm thick	30μ" MIN	100μ" MIN	50μ" MIN	100μ" MIN	100μ" MIN	50μ" MIN	Black UL 94V-0	0.25mm thick	0.20mm thick

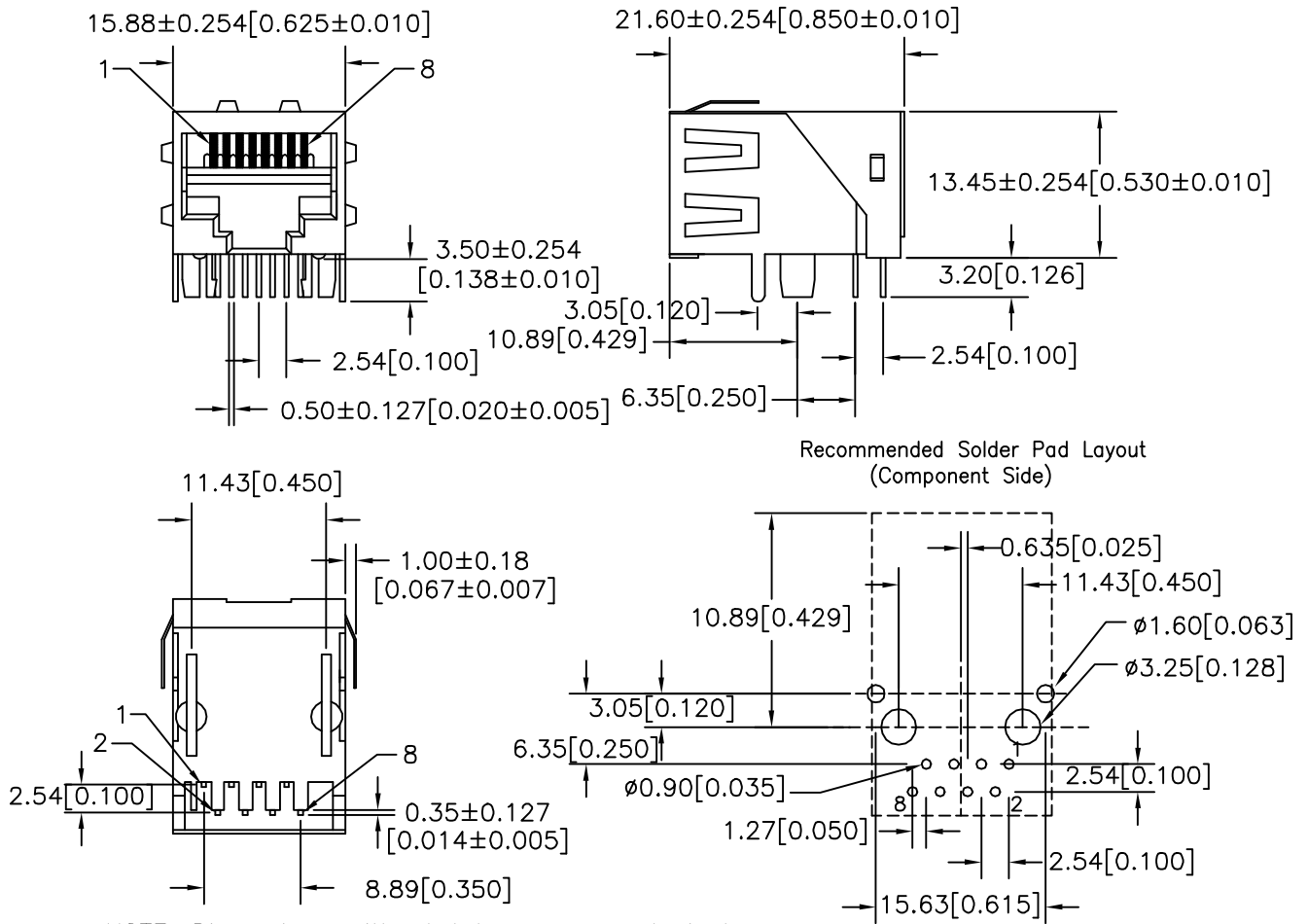

NOTE: Dimensions without tolerances are typical.

PREPARED BY:

D. Rund

ENGINEER:

L. Le

QUALITY CONTROL:

D. Kelley

APPROVED:

J. Coleman

DWG CONTROL NO. REV  
P-A1-12906 PRE  
ACAD\TTC\A1129062.DWG

RJ45  
INTEGRATED CONNECTOR  
**TAMURA CORPORATION OF AMERICA**  
43352 BUSINESS PARK DRIVE, TEMECULA, CA. 92590-6624  
(909) 699-1270 FAX 9096769482

**TIC-L001-11**  
MODEL SPECIFICATION

DIM: mm(In) SCL: NONE SH: 2 OF 2

PROPRIETARY NOTICE: THIS DRAWING PRINT OR DOCUMENT AND SUBJECT MATTER DISCLOSED HEREIN ARE PROPRIETARY ITEMS TO WHICH TAMURA RETAINS THE EXCLUSIVE RIGHT OF DISSEMINATION, REPRODUCTION, MANUFACTURE AND SALE. THIS DRAWING, PRINT OR DOCUMENT IS SUBMITTED IN CONFIDENCE FOR CONSIDERATION BY THE RECIPIENT ALONE UNLESS PERMISSION FOR FURTHER DISCLOSURE IS EXPRESSLY GRANTED IN WRITING.