

4

3

2

1

THIS DRAWING IS UNPUBLISHED. RELEASED FOR PUBLICATION
 © COPYRIGHT - BY TYCO ELECTRONICS CORPORATION. ALL RIGHTS RESERVED.

LOC	DIST	REVISIONS				
P	LTR	DESCRIPTION	DATE	DWN	APVD	
GP	00					
0		RELEASED PER EC 0513-0207-05	28JUN05	SW	JG	

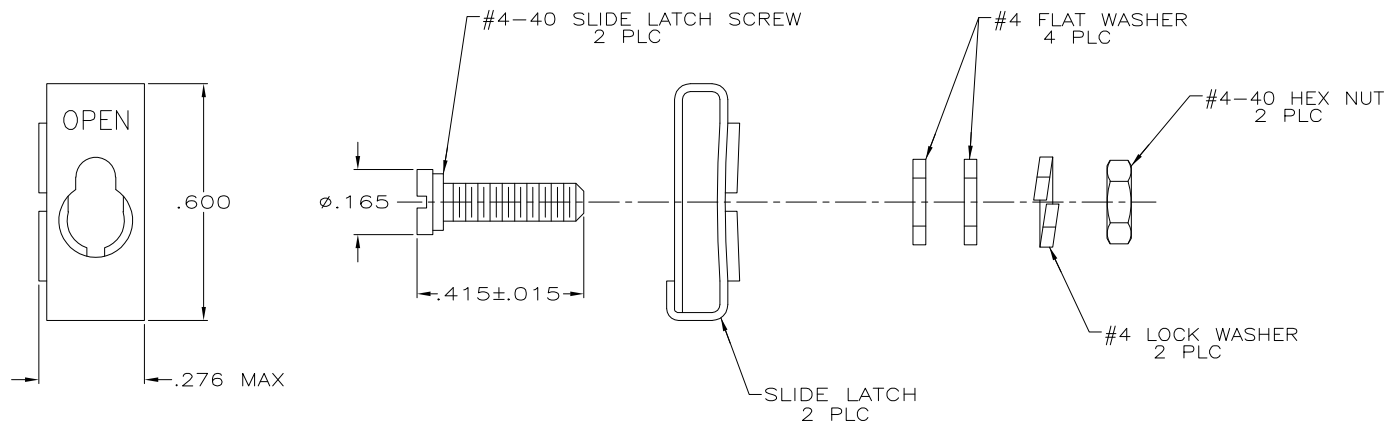

1. PARTS PACKAGED UNASSEMBLED.
2. PARTS PACKAGED AS A UNIT KIT.
3. PARTS INDIVIDUALLY BULK PACKED & SHIPPED AS A UNIT PACKAGE.
4. ZINC PLATED .000200-.000400 THICK, YELLOW CHROMATE COATING.
5. THIS KIT CAN BE USED WITH ONE-PIECE STRAIGHT/45° EXIT CABLE CLAMPS, ONE-PIECE STRAIGHT/90° EXIT CABLE CLAMPS, OR ON CONNECTORS WITHOUT CABLE CLAMPS.

3	5206942-2
2	5206942-1
PACKAGING	PART NO

THIS DRAWING IS A CONTROLLED DOCUMENT.		DWN	S. WAITMAN	28JUN05	 Tyco Electronics Corporation Harrisburg, Pa 17105-3608
DIMENSIONS:		CHK	C. RÖHDE	28JUN05	
INCHES		APVD	M. WALMSLEY	28JUN05	
TOLERANCES UNLESS OTHERWISE SPECIFIED:		NAME		KIT, TWO-PIECE SLIDE LATCH, SIZES 1 THRU 4, AMPLIMITE	
0 PLC ± -		PRODUCT SPEC		-	
1 PLC ± -		APPLICATION SPEC		-	
2 PLC ± -		WEIGHT		-	
3 PLC ± .005		SIZE	A3	CAGE CODE	00779
4 PLC ± -		DRAWING NO	C=5206942		RESTRICTED TO
ANGLES ± -		CUSTOMER DRAWING		SCALE	4:1
MATERIAL		FINISH		SHEET	1 OF 1
SLIDE LATCH: STAINLESS STEEL		HARDWARE: 4		REV	0
HARDWARE: STEEL					

AMP 1470-19 REV 31MAR2000