

DESCRIPTION: QUICK RELEASE - CONNECTOR POST OPTIONS

POSITIONS	LOCATION	PANEL CUT OUT DIMENSIONS						
		A	B	C	D	E	F	G
9 STD / 15 H.D.	FRONT	0.984	0.492	0.874	0.437	0.513	0.257	0.083
	BACK	0.984	0.492	0.806	0.403	0.449	0.225	0.132
15 STD / 26 H.D.	FRONT	1.312	0.656	1.202	0.601	0.513	0.257	0.083
	BACK	1.312	0.656	1.134	0.567	0.449	0.225	0.132
25 STD / 44 H.D.	FRONT	1.852	0.926	1.743	0.872	0.513	0.257	0.083
	BACK	1.852	0.926	1.674	0.842	0.449	0.225	0.132
37 STD / 62 H.D.	FRONT	2.500	1.250	2.391	1.196	0.513	0.257	0.083
	BACK	2.500	1.250	2.326	1.163	0.449	0.225	0.132

PANEL THICKNESS	KIT PART NUMBER	QUANTITY IN KIT			
		①	②	③	④
①					
0.118 Max.	QLOCK POST-1	2	2	4	2
0.039 - 0.051	QLOCK POST-2	2	2	4	2
0.059 - 0.071	QLOCK POST-3	2	4	4	2
0.067 - 0.079	QLOCK POST-5	2	4	4	2
0.087 - 0.098	QLOCK POST-6	2	2	4	2

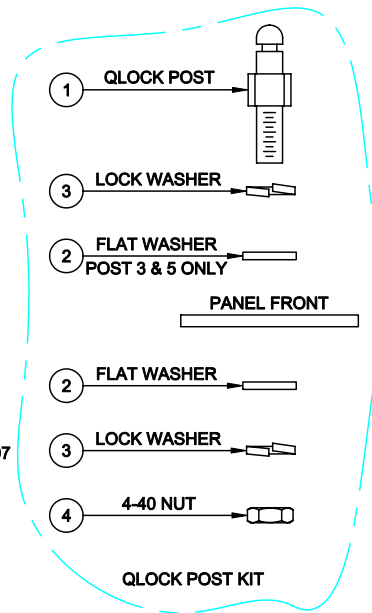
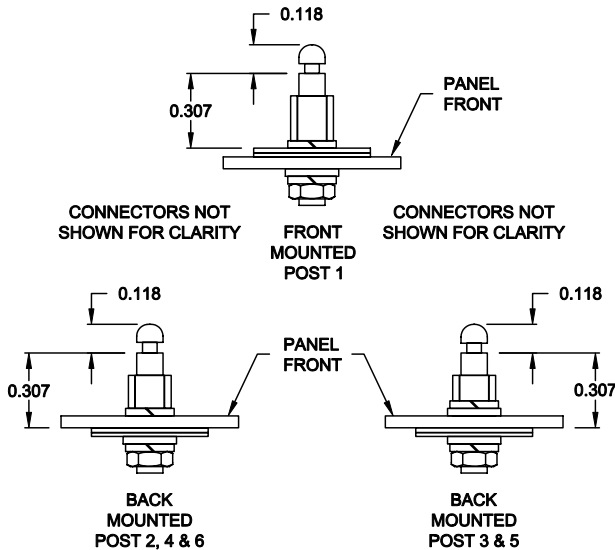
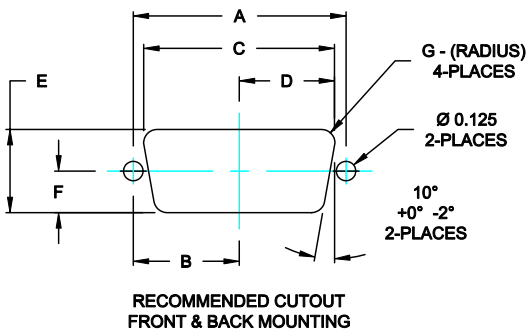
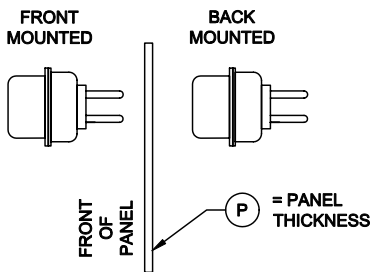

DO NOT SCALE FROM DRAWING

	THESE DRAWINGS AND SPECIFICATIONS ARE THE PROPERTY OF NorComp AND SHALL NOT BE REPRODUCED, COPIED OR USED AS THE BASIS FOR THE MANUFACTURE OF SALE OF APPARATUS WITHOUT WRITTEN PERMISSION.	DRAWN: C. SMITH	DATE: 04-10-07	
		CHECKED:	DATE:	
<h1>NorComp</h1>		SCALE: 1:1	SHEET 1 OF 1	REV 1
		DWG NO. QLOCK POST-Y		

RoHS COMPLIANT