

DESCRIPTION: 4-40 FEMALE SCREWLOCK

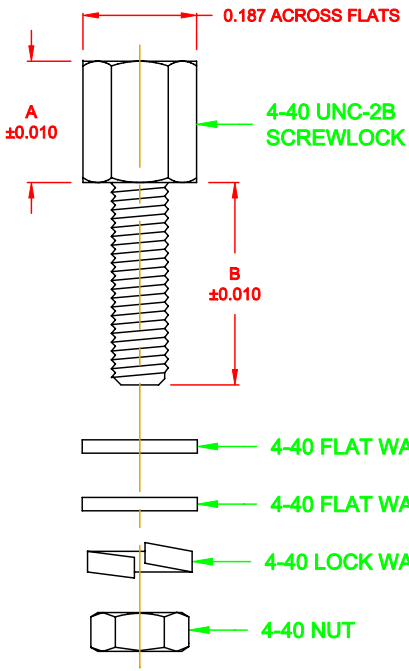

MATERIAL: BRASS - C3604
PLATING: NICKEL
TORQUE VALUE: 4 - 5 IN. LBS. Max

PART NUMBER	A	B	PKG
160-000-010R031	0.187	0.312	KIT
160-000-010R032	0.187	0.312	BULK
160-000-011R031	0.187	0.625	KIT
160-000-011R032	0.187	0.625	BULK
160-000-012R031	0.250	0.156	KIT
160-000-012R032	0.250	0.156	BULK
160-000-013R031	0.197	0.197	KIT
160-000-013R032	0.197	0.197	BULK
160-000-014R031	0.197	0.236	KIT
160-000-014R032	0.197	0.236	BULK
160-000-015R031	0.197	0.323	KIT
160-000-015R032	0.197	0.323	BULK
160-000-016R031	0.197	0.433	KIT
160-000-016R032	0.197	0.433	BULK
160-000-017R031	0.197	0.520	KIT
160-000-017R032	0.197	0.520	BULK
160-000-018R031	0.197	0.669	KIT
160-000-018R032	0.197	0.669	BULK

KIT INCLUDES:
 1 - 4-40 UNC-2B FEMALE SCREWLOCK
 2 - 4-40 FLAT WASHERS
 1 - 4-40 LOCK WASHERS
 1 - 4-40 NUTS

DO NOT SCALE FROM DRAWING

RoHS COMPLIANT

	THESE DRAWINGS AND SPECIFICATIONS ARE THE PROPERTY OF NorComp AND SHALL NOT BE REPRODUCED, COPIED OR USED AS THE BASIS FOR THE MANUFACTURE OF SALE OF APPARATUS WITHOUT WRITTEN PERMISSION.		DRAWN: PAM JENKINS	DATE: 5-14-05
			CHECKED:	DATE:
NorComp		SCALE:	SHEET 1 OF 1	REV 2
		DWG NO. 160-000-011R03Y		