

4

3

2

1

THIS DRAWING IS UNPUBLISHED. RELEASED FOR PUBLICATION
 © COPYRIGHT - BY TYCO ELECTRONICS CORPORATION. ALL RIGHTS RESERVED.

LOC	DIST	REVISIONS					
BD	48	P	LTR	DESCRIPTION	DATE	DWN	APVD
		A		REVISED PER ECO-06-023509	04DEC06	JDP	CWR

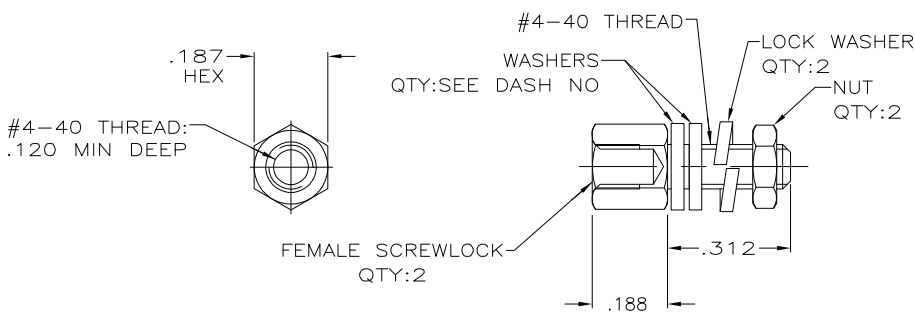

- 1 ZINC PLATED .000200-000400 THICK YELLOW CHROMATE COATING.
- 2 ZINC PLATED .000200-000400 THICK CLEAR CHROMATE COATING.
- 3. PARTS PACKAGED UNASSEMBLED.
- 4 PARTS PACKED AS A UNIT KIT.
- 5 PARTS INDIVIDUALLY BULK PACKED & SHIPPED AS A UNIT PACKAGE.
- 6. IDENTIFIED BY MIL SPEC PART NUMBER M24308/26-01 FOR -8 ONLY & TYCO PART NUMBER (FOR ALL DASH NUMBERS).
- 7 CHROMATE FINISH PER ASTM B633 EXCEPT FOR USE OF TRIVALENT CHROMIUM TO MEET RoHS REGULATIONS.

4	6	1	5205817-8
5	4	2	5205817-4
4	4	2	5205817-3
5	4	1	5205817-2
4	4	1	5205817-1
PACKAGING	NO OF WASHERS	FINISH	PART NUMBER

THIS DRAWING IS A CONTROLLED DOCUMENT.		DWN S. WAITMAN 27JUN05	Tyco Electronics Corporation Harrisburg, PA 17105-3608															
DIMENSIONS: INCHES		CHK C. ROHDE 27JUN05	APVD M. WALMSLEY 27JUN05															
<table border="1"> <tr> <th>TOLERANCES UNLESS OTHERWISE SPECIFIED:</th> <th></th> </tr> <tr> <td>0 PLC</td> <td>± -</td> </tr> <tr> <td>1 PLC</td> <td>± -</td> </tr> <tr> <td>2 PLC</td> <td>± -</td> </tr> <tr> <td>3 PLC</td> <td>± .005</td> </tr> <tr> <td>4 PLC</td> <td>± -</td> </tr> <tr> <td>ANGLES</td> <td>± -</td> </tr> </table>		TOLERANCES UNLESS OTHERWISE SPECIFIED:		0 PLC	± -	1 PLC	± -	2 PLC	± -	3 PLC	± .005	4 PLC	± -	ANGLES	± -	NAME KIT, SCREWLOCK, FEMALE, AMPLIMITE		
TOLERANCES UNLESS OTHERWISE SPECIFIED:																		
0 PLC	± -																	
1 PLC	± -																	
2 PLC	± -																	
3 PLC	± .005																	
4 PLC	± -																	
ANGLES	± -																	
MATERIAL COLD ROLLED STEEL		FINISH SEE TABLE																
WEIGHT		SIZE A3	CAGE CODE 00779	DRAWING NO C-5205817														
CUSTOMER DRAWING		SCALE 4:1		SHEET 1 OF 1 REV A														

AMP 1470-19 REV 31MAR2000