

ELECTRICAL SPECIFICATIONS:

- 1.0 TURNS RATIO: (P3-P2) : (J4-J5) : 1 : 1 ±2%
 (P5-P4) : (J6-J3) : 1 : 1 ±2%
 (P9-P8) : (J8-J7) : 1 : 1 ±2%
 (P10-P11) : (J2-J1) : 1 : 1 ±2%
- 2.0 INDUCTANCE: (P3-P2) ; (P5-P4) : 350 uH MIN. @ 0.1V, 100KHz, 8 mA DC BIAS
 (P10-P11) ; (P9-P8) : 350 uH MIN. @ 0.1V, 100KHz, 8 mA DC BIAS
- 3.0 LEAKAGE INDUCTANCE: P3-P2 (WITH J4 AND J5 SHORT) : 0.3uH MAX. @ 1MHz
 P5-P4 (WITH J6 AND J3 SHORT) : 0.3uH MAX. @ 1MHz
 P9-P8 (WITH J8 AND J7 SHORT) : 0.3uH MAX. @ 1MHz
 P10-P11 (WITH J1 AND J2 SHORT) : 0.3uH MAX. @ 1MHz
- 4.0 INTERWINDING CAPACITANCE: (P3-P2) : (J4-J5) : 35pf MAX @ 1MHz
 (P5-P4) : (J6-J3) : 35pf MAX @ 1MHz
 (P9-P8) : (J5-J4) : 35pf MAX @ 1MHz
 (P10-P11) : (J2-J1) : 35pf MAX @ 1MHz
- 5.0 DC RESISTANCE: (J6-J3) ; (J2-J1) ; (J7-J8) : (J4-J5) : 1.2 ohms Max.

Bel Stewart Connector
 11118 Susquehanna Trail, South
 Glen Rock, Pa 17327-9199
 717.234.7512

MagJack®
<http://www.stewartconnector.com>

THIS DRAWING AND THE SUBJECT MATTER SHOWN THEREON ARE CONFIDENTIAL AND PROPERTY OF BEL STEWART CONNECTOR AND SHALL NOT BE REPRODUCED, COPIED, OR USED IN ANY MANNER WITHOUT PRIOR WRITTEN CONTENT OF BEL STEWART CONNECTOR. THE SUBJECT MATTER MAY BE PATENTED OR A PATENT MAY BE PENDING.

SHEET 1 OF 4	DRAWING NO. SI-50080	REV. 10
-----------------	-------------------------	------------

6.0 RETURN LOSS: 1MHz TO 30MHz	:	-19dB MIN.
30MHz TO 60MHz	:	-13dB MIN.
60MHz TO 80MHz	:	-12dB MIN.
80MHz TO 100MHz	:	-10dB MIN.
7.0 DIELECTRIC WITHSTAND: (J1,J2) TO (P10,P11) ; (J5,J4) TO (P3-P2)	:	1500 VAC
(J3,J6) TO (P5,P4) ; (J8,J7) TO (P9, P8)	:	1500 VAC
8.0 INSERTION LOSS: RS=RL=100 ohms	:	-1.1 dB TYP
100KHz TO 125MHz	:	
9.0 RISE TIME: RS=100 OHMS AND RL = 100 OHMS	:	
OUTPUT VOLTAGE = 1 V peak	:	3.0 nS MAX
PULSE WIDTH= 112nS	:	3.0 nS MAX
10.0 CROSS TALK: 1-100 MHz	:	$-[33-20 \text{ LOG } (\frac{F}{50 \text{ MHz}})] \text{ MIN.}$
11.0 COMMON TO COMMON MODE ATTENUATION: 1MHz TO 100MHz	:	-35dB TYP

Bel Stewart Connector
11118 Susquehanna Trail, South
Glen Rock, Pa 17327-9199
717.234.7512

MagJack®
<http://www.stewartconnector.com>

THIS DRAWING AND THE SUBJECT MATTER SHOWN THEREON ARE CONFIDENTIAL AND PROPERTY OF BEL STEWART CONNECTOR AND SHALL NOT BE REPRODUCED, COPIED, OR USED IN ANY MANNER WITHOUT PRIOR WRITTEN CONTENT OF BEL STEWART CONNECTOR. THE SUBJECT MATTER MAY BE PATENTED OR A PATENT MAY BE PENDING.

SHEET 2 OF 4	DRAWING NO. SI-50080	REV. 10
-----------------	-------------------------	------------

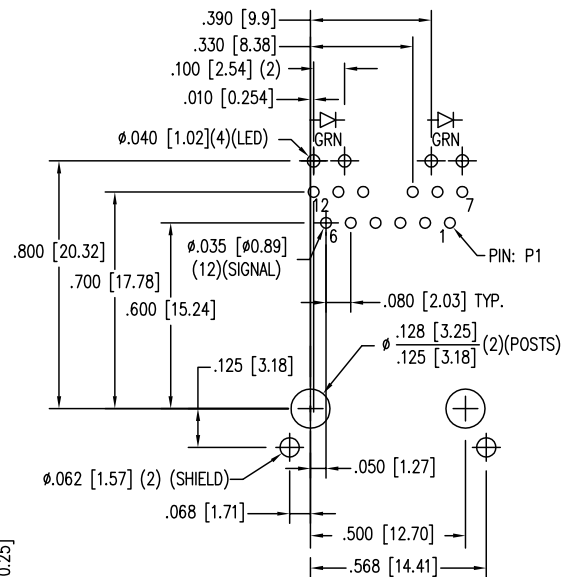
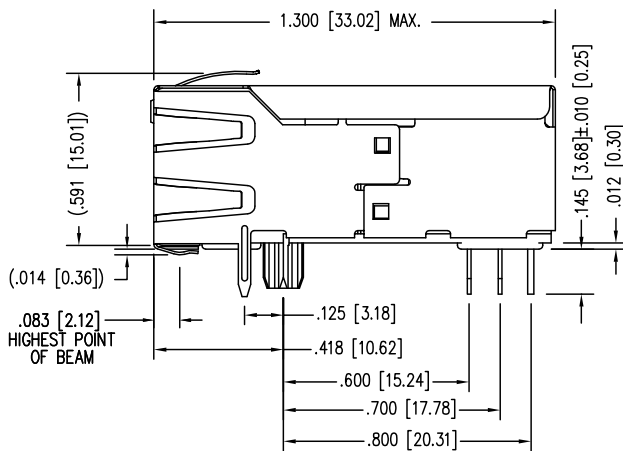
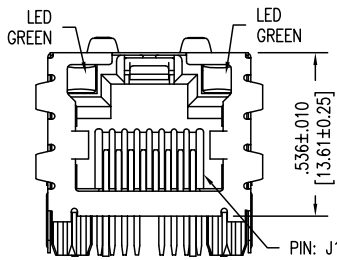
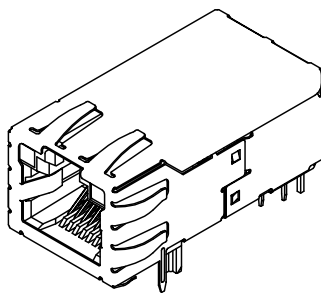
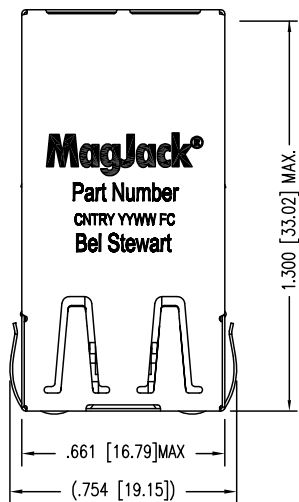

NOTES:

- CONNECTOR MATERIALS:
HOUSING: THERMOPLASTIC UL94 V-0
CONTACT/SHIELD: COPPER ALLOY
SHIELD PLATING: NICKEL OR TIN
CONTACT PLATING: SELECTIVE GOLD,
50 MICRO-INCHES MIN. IN CONTACT AREA.
- PIN NOT ELECTRICALLY CONNECTED MAYBE OMITTED.
SEE ELECTRICAL DRAWING FOR OMITTED PINS.
- TOLERANCES COMPLY WITH F.C.C. DIMENSION REQUIREMENTS.
- THE SUGGESTED PANEL OPENING IS INTENDED TO GIVE
USER THE ABILITY TO HAVE REASONABLE JACK/PANEL
CLEARANCES, YET MAINTAIN GROUNDING CAPABILITY.
- SOLDER REFLOW COMPATIBLE - 230°C/90 SEC MAX.

STANDARD LED	WAVELENGTH	* Forward V (MAX)	(TYP)
GREEN	565 nm	2.5 V	2.2 V

* WITH A FORWARD CURRENT OF 20 mA

Bel Stewart Connector
11118 Susquehanna Trail, South
Glen Rock, Pa 17327-9199
717.234.7512



<http://www.stewartconnector.com>

THIS DRAWING AND THE SUBJECT MATTER SHOWN THEREON ARE CONFIDENTIAL AND PROPERTY OF BEL STEWART CONNECTOR AND SHALL NOT BE REPRODUCED, COPIED, OR USED IN ANY MANNER WITHOUT PRIOR WRITTEN CONTENT OF BEL STEWART CONNECTOR. THE SUBJECT MATTER MAY BE PATENTED OR A PATENT MAY BE PENDING.

SHEET 3 OF 4	DRAWING NO. SI-50080	REV. 04
-----------------	-------------------------	------------

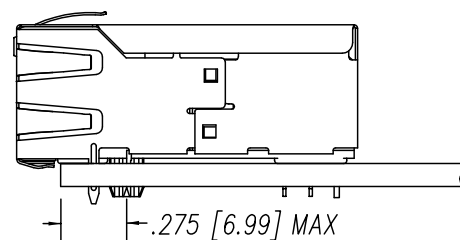
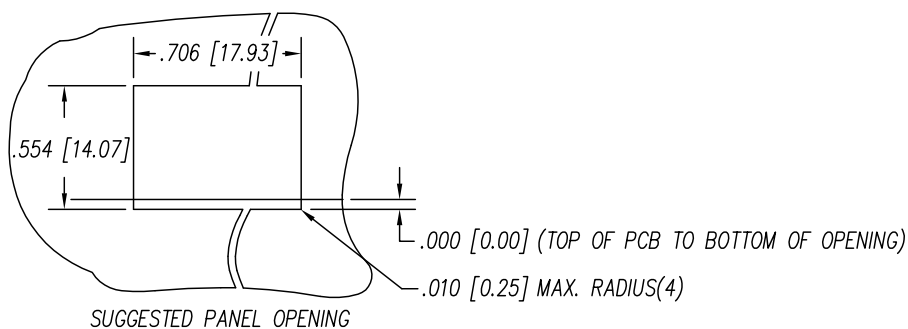

THE SUGGESTED PANEL OPENING IS INTENDED TO GIVE THE USER THE ABILITY TO HAVE REASONABLE JACK / PANEL CLEARANCES YET MAINTAIN RELIABLE GROUNDING CAPABILITY.

Bel Stewart Connector
 11118 Susquehanna Trail, South
 Glen Rock, Pa 17327-9199
 717.234.7512

MagJack®

<http://www.stewartconnector.com>

THIS DRAWING AND THE SUBJECT MATTER SHOWN THEREON ARE CONFIDENTIAL AND PROPERTY OF BEL STEWART CONNECTOR AND SHALL NOT BE REPRODUCED, COPIED, OR USED IN ANY MANNER WITHOUT PRIOR WRITTEN CONTENT OF BEL STEWART CONNECTOR. THE SUBJECT MATTER MAY BE PATENTED OR A PATENT MAY BE PENDING.

SHEET
4 OF 4

DRAWING NO.

SI-50080

REV. 04