

ELECTRICAL SPECIFICATIONS:

1.0 TURNS RATIO: (P1-P3) : (J1-J2) : 1CT : 2.5CT ± 2%
(P4-P6) : (J3-J6) : 1CT : 1CT ± 2%



Bel Stewart Connector
11118 Susquehanna Trail, South
Glen Rock, Pa 17327-9199
717.234.7512
<http://www.stewartconnector.com>



THIS DRAWING AND THE SUBJECT MATTER SHOWN THEREON ARE CONFIDENTIAL AND PROPERTY OF BEL STEWART CONNECTOR AND SHALL NOT BE REPRODUCED, COPIED, OR USED IN ANY MANNER WITHOUT PRIOR WRITTEN CONTENT OF BEL STEWART CONNECTOR. THE SUBJECT MATTER MAY BE PATENTED OR A PATENT MAY BE PENDING.

SHEET 1 OF 4	DRAWING NO. SI-52006-F	REV. X1
-----------------	---------------------------	------------

ELECTRICAL SPECIFICATIONS:

3.0 INDUCTANCE: (P1-P3) : 45uH MIN. @ 0.1V, 100KHz
(P4-P6) : 230uH MIN. @ 0.1V, 100KHz

4.0 RETURN LOSS: (P1-P3)=100 OHMS REF. AND (P4-P6)=100 OHM REF.
1MHz TO 10MHz : -18dB MIN.

5.0 INSERTION LOSS: RS & RL =100 ohms
1MHz TO 10MHz : -1.0dB MAX

6.0 CROSS TALK: 1MHz - 10 MHz : -40dB MIN

7.0 CM TO CM ATTENUATION: 10MHz - 30 MHz : -40dB MIN
100MHz : -30dB MIN

8.0 DIELECTRIC WITHSTAND: (P1-P3) TO (J1-J2) : 1500 Vrms
(P4-P6) TO (J3-J6) : 1500 Vrms

OPERATING TEMPERATURE RANGE: -40 TO +85°C

Bel Stewart Connector
11118 Susquehanna Trail, South
Glen Rock, Pa 17327-9199
717.234.7512

MagJack[®]

<http://www.stewartconnector.com>

THIS DRAWING AND THE SUBJECT MATTER SHOWN THEREON ARE CONFIDENTIAL AND PROPERTY OF BEL STEWART CONNECTOR AND SHALL NOT BE REPRODUCED, COPIED, OR USED IN ANY MANNER WITHOUT PRIOR WRITTEN CONTENT OF BEL STEWART CONNECTOR. THE SUBJECT MATTER MAY BE PATENTED OR A PATENT MAY BE PENDING.

SHEET
2 OF 4

DRAWING NO. SI-52006-F

REV. X1

LED SPECIFICATION			
STANDARD LED	WAVELENGTH	FORWARD V (MAX)	* (TYP)
GREEN	565 nm	2.5 V	2.2 V
YELLOW	590 nm	2.5 V	2.1 V

*WITH A FORWARD CURRENT OF 20 mA (TYP)

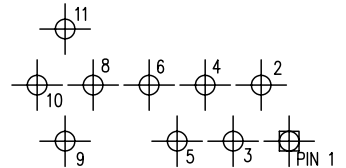
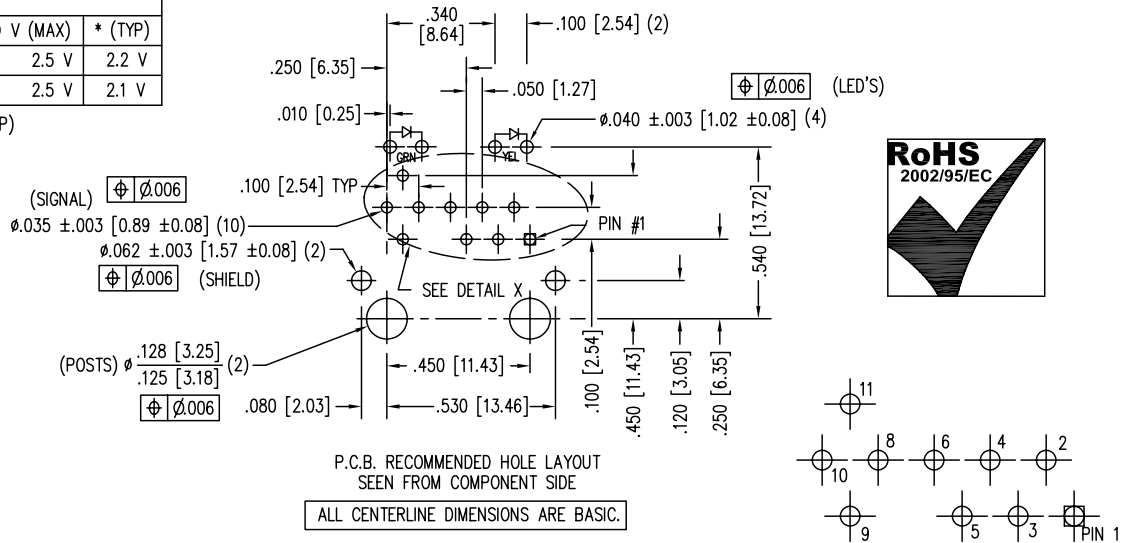
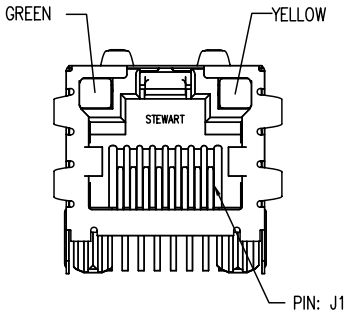
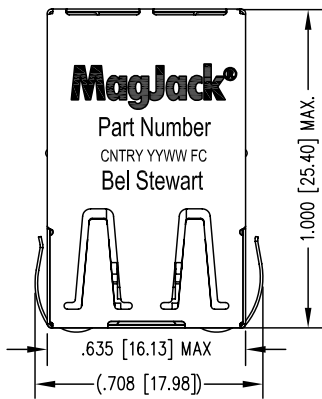

DETAIL X

NOTES:

- CONNECTOR MATERIALS:
HOUSING: THERMOPLASTIC UL94 V-0
CONTACT/SHIELD: COPPER ALLOY
SHIELD PLATING: NICKEL OR TIN
CONTACT PLATING: SELECTIVE GOLD,
50 MICRO-INCHES MIN. IN CONTACT AREA.
- PIN NOT ELECTRICALLY CONNECTED MAYBE OMITTED.
SEE ELECTRICAL DRAWING FOR OMITTED PINS.
- TOLERANCES COMPLY WITH F.C.C. DIMENSION REQUIREMENTS.
- ALL TOLERANCES NOT OTHERWISE SPECIFIED TO BE ± 0.005 [0.13]
- REFLOW AND WAVE SOLDER COMPATIBLE -260°C FOR 10 SECONDS MAX.

Bel Stewart Connector
11118 Susquehanna Trail, South
Glen Rock, Pa 17327-9199
717.234.7512



<http://www.stewartconnector.com>

THIS DRAWING AND THE SUBJECT MATTER SHOWN THEREON ARE CONFIDENTIAL AND PROPERTY OF BEL STEWART CONNECTOR AND SHALL NOT BE REPRODUCED, COPIED, OR USED IN ANY MANNER WITHOUT PRIOR WRITTEN CONTENT OF BEL STEWART CONNECTOR. THE SUBJECT MATTER MAY BE PATENTED OR A PATENT MAY BE PENDING.

SHEET 3 OF 4 DRAWING NO. SI-52006-F REV. X2

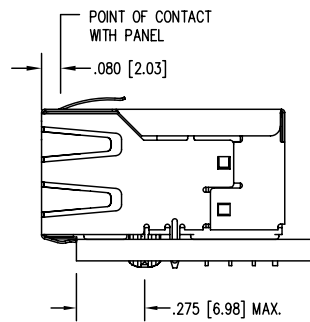
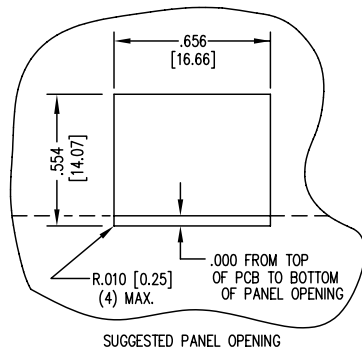

1. THE SUGGESTED PANEL OPENING IS INTENDED TO GIVE THE USER THE ABILITY TO HAVE REASONABLE JACK / PANEL CLEARANCES YET MAINTAIN RELIABLE GROUNDING CAPABILITY.
2. ALL TOLERANCES NOT OTHERWISE SPECIFIED TO BE $\pm .005$ [0.13]

Bel Stewart Connector
 11118 Susquehanna Trail, South
 Glen Rock, Pa 17327-9199
 717.234.7512

MagJack[®]

<http://www.stewartconnector.com>

THIS DRAWING AND THE SUBJECT MATTER SHOWN THEREON ARE CONFIDENTIAL AND PROPERTY OF BEL STEWART CONNECTOR AND SHALL NOT BE REPRODUCED, COPIED, OR USED IN ANY MANNER WITHOUT PRIOR WRITTEN CONTENT OF BEL STEWART CONNECTOR. THE SUBJECT MATTER MAY BE PATENTED OR A PATENT MAY BE PENDING.

SHEET
4 OF 4

DRAWING NO. SI-52006-F

REV. X1