

ELECTRICAL SPECIFICATIONS:

- | | | |
|--|---------|--|
| 1.0 TURNS RATIO: (P6-P5-P4) : | (J6-J3) | : 1CT : 1CT ± 3% |
| (P3-P2-P1) : | (J2-J1) | : 1CT : 1CT ± 3% |
| 2.0 INDUCTANCE: (P6-P4) | | : 350uH MIN. @ 0.1V, 100KHz, 8mA DC Bias |
| (P3-P1) | | : 350uH MIN. @ 0.1V, 100KHz, 8mA DC Bias |
| 3.0 LEAKAGE INDUCTANCE: P6-P4 (WITH J6 AND J3 SHORT) | | : 0.3 MAX. @ 1MHz |
| P3-P1 (WITH J2 AND J1 SHORT) | | : 0.3 MAX. @ 1MHz |
| 4.0 INTERWINDING CAPACITANCE: (P6,P5,P4) TO (J6,J3) | | : 30pf MAX @ 1MHz |
| (P3,P2,P1) TO (J2,J1) | | : 30pf MAX. @ 1MHz |
| 5.0 DC RESISTANCE: (J6-J3)=(J2-J1) | | : 1.2 ohms Max. |

NOTES

1.0 PINS WITHOUT ELECTRICAL CONNECTION ARE OMITTED.

Bel Stewart Connector
 11118 Susquehanna Trail, South
 Glen Rock, Pa 17327-9199
 717.234.7512

MagJack®

<http://www.stewartconnector.com>

THIS DRAWING AND THE SUBJECT MATTER SHOWN THEREON ARE CONFIDENTIAL AND PROPERTY OF BEL STEWART CONNECTOR AND SHALL NOT BE REPRODUCED, COPIED, OR USED IN ANY MANNER WITHOUT PRIOR WRITTEN CONTENT OF BEL STEWART CONNECTOR. THE SUBJECT MATTER MAY BE PATENTED OR A PATENT MAY BE PENDING.

SHEET 1 OF 4

DRAWING NO. SI-40141

REV. 17

RECEIVE

6.0 RETURN LOSS: 1MHz TO 30MHz : 18dB MIN.
60MHz TO 80MHz : 12dB MIN.

NOTE: 100 OHMS CONNECTED TO (J2-J1) OR (J6-J3).

7.0 DIELECTRIC WITHSTAND: (J1, J2) TO (P1, P3) : 1500 VAC
(J3, J6) TO (P4, P6) : 1500 VAC

8.0 INSERTION LOSS: RS=RL=100 ohms : 1.1 dB TYP
100kHz TO 100MHz

9.0 RISE TIME: RS=100 OHMS AND RL = 100 OHMS : 3.0 nS MAX
OUTPUT VOLTAGE = 1 V peak : 3.0 nS MAX
PULSE WIDTH= 112nS

10.0 CROSS TALK: 1MHz TO 100MHz : 40 dB TYP

11.0 COMMON TO COMMON MODE ATTENUATION: 30MHz TO 100MHz : 35dB TYP

Bel Stewart Connector
11118 Susquehanna Trail, South
Glen Rock, Pa 17327-9199
717.234.7512

MagJack[®]

<http://www.stewartconnector.com>

THIS DRAWING AND THE SUBJECT MATTER SHOWN THEREON ARE CONFIDENTIAL AND PROPERTY OF BEL STEWART CONNECTOR AND SHALL NOT BE REPRODUCED, COPIED, OR USED IN ANY MANNER WITHOUT PRIOR WRITTEN CONTENT OF BEL STEWART CONNECTOR. THE SUBJECT MATTER MAY BE PATENTED OR A PATENT MAY BE PENDING.

SHEET 2 OF 4

DRAWING NO. SI-40141

REV. 17

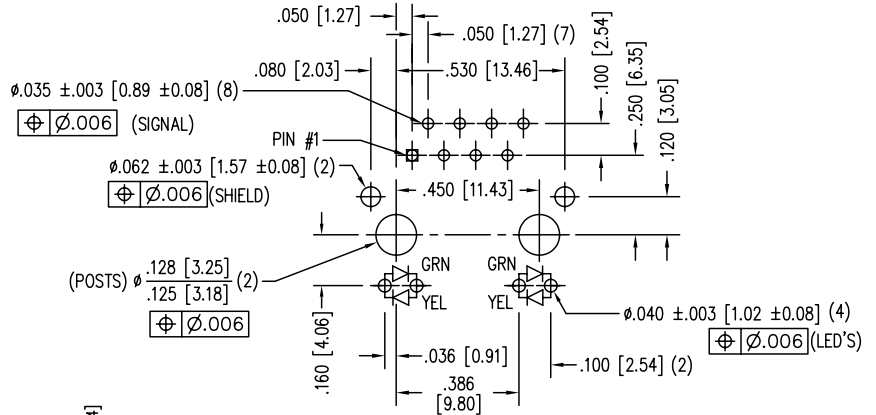
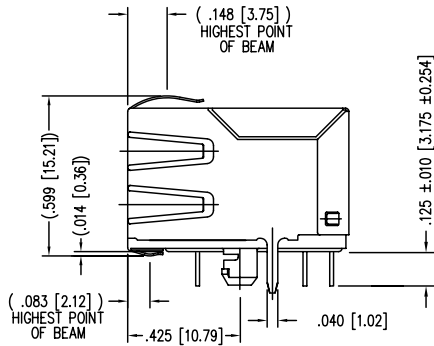
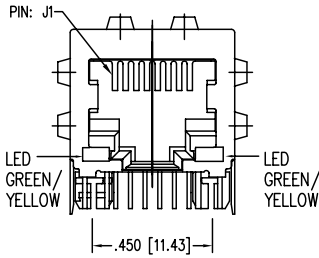
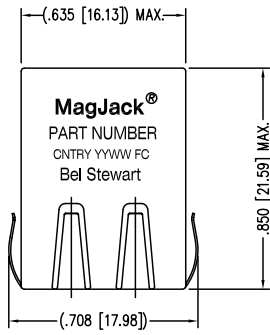

P.C.B. RECOMMENDED HOLE LAYOUT
SEEN FROM COMPONENT SIDE
ALL CENTERLINE DIMENSIONS ARE BASIC.

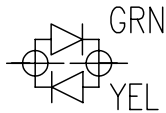

TYP. LED POLARITY

LED SPECIFICATION			
STANDARD LED	WAVELENGTH	FORWARD V (MAX)	* (TYP)
GREEN	565 nm	2.5 V	2.2 V
YELLOW	590 nm	2.5 V	2.1 V

*WITH A FORWARD CURRENT OF 20 mA (TYP)

NOTES:

- CONNECTOR MATERIALS:
HOUSING: THERMOPLASTIC UL94 V-0
CONTACT/SHIELD: COPPER ALLOY
SHIELD PLATING: NICKEL OR TIN
CONTACT PLATING: SELECTIVE GOLD,
50 MICRO-INCHES MIN. IN CONTACT AREA.
- PIN NOT ELECTRICALLY CONNECTED MAYBE OMITTED.
SEE ELECTRICAL DRAWING FOR OMITTED PINS.
- TOLERANCES COMPLY WITH F.C.C. DIMENSION REQUIREMENTS.
- ALL TOLERANCES NOT OTHERWISE SPECIFIED TO BE ±.005 [0.13]
- WAVE SOLDER COMPATIBLE - PREHEAT 125°C/90SECS.

Bel Stewart Connector
11118 Susquehanna Trail, South
Glen Rock, Pa 17327-9199
717.234.7512
MagJack
<http://www.stewartconnector.com>

SHEET 3 OF 4 DRAWING NO. SI-40141 REV. 06

THIS DRAWING AND THE SUBJECT MATTER SHOWN THEREON ARE CONFIDENTIAL AND PROPERTY OF BEL STEWART CONNECTOR AND SHALL NOT BE REPRODUCED, COPIED, OR USED IN ANY MANNER WITHOUT PRIOR WRITTEN CONTENT OF BEL STEWART CONNECTOR. THE SUBJECT MATTER MAY BE PATENTED OR A PATENT MAY BE PENDING.

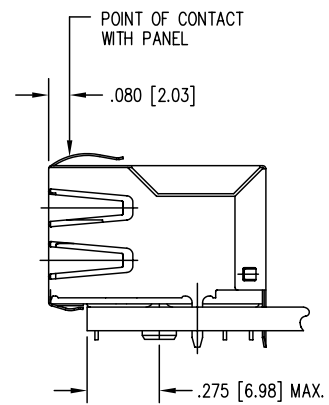
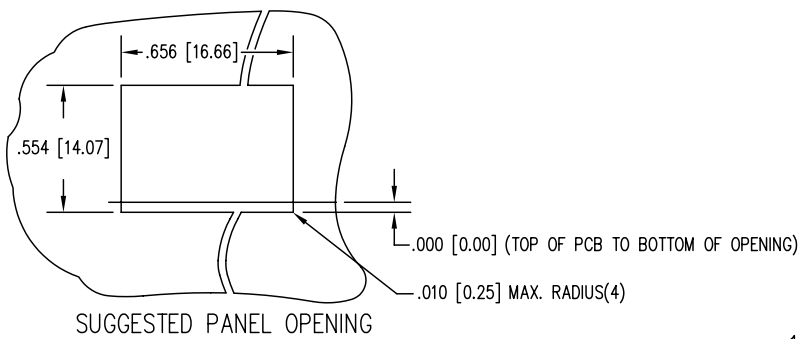

1. THE SUGGESTED PANEL OPENING IS INTENDED TO GIVE THE USER THE ABILITY TO HAVE REASONABLE JACK / PANEL CLEARANCES YET MAINTAIN RELIABLE GROUNDING CAPABILITY.
2. ALL TOLERANCES NOT OTHERWISE SPECIFIED TO BE ± 0.005 [0.13]

Bel Stewart Connector
 11118 Susquehanna Trail, South
 Glen Rock, Pa 17327-9199
 717.234.7512

MagJack

<http://www.stewartconnector.com>

THIS DRAWING AND THE SUBJECT MATTER SHOWN THEREON ARE CONFIDENTIAL AND PROPERTY OF BEL STEWART CONNECTOR AND SHALL NOT BE REPRODUCED, COPIED, OR USED IN ANY MANNER WITHOUT PRIOR WRITTEN CONTENT OF BEL STEWART CONNECTOR. THE SUBJECT MATTER MAY BE PATENTED OR A PATENT MAY BE PENDING.

SHEET
4 OF 4

DRAWING NO. SI-40141 REV. 05