

**Description:** 10/100/1000 Base-TX RJ45 2xN Integrated Magnetics Connector without LEDs, designed to support such applications as: Switches, Routers, Servers and Hub.

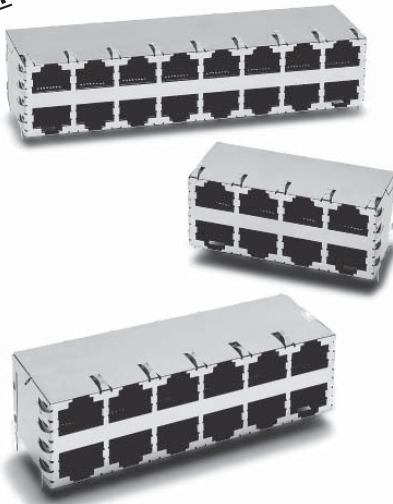

### Features and Benefits:

- ⊕ RoHS peak wave solder temperature rating 260°C
- ⊕ 2xN RJ45 with internal magnetics
- ⊕ Suitable for CAT 3, 5, 6 UTP cable or better
- ⊕ Internal magnetics are 100% electrically tested for HI-POT and functionality per IEEE802.3 requirement
- ⊕ Meets or exceeds IEEE 802.3ab standard for 1000Base-T

### Electrical Performance Summary:

- ⊕ 350 μH minimum OCL with 8mA bias current
- ⊕ High performance for maximum EMI suppression
- ⊕ Meets or exceeds IEEE 802.3ab standard for 1000Base-T

### Electrical Specifications @ 25°C — Operating Temperature 0°C to +70°C

RoHS Compliant Part Number	Insertion Loss TX/RX (dB MIN)	Return Loss (dB TYP) 100 Ω (±15 Ω)			Crosstalk (dB TYP)			Common Mode Rejection (dB TYP)		Hipot (Vdc MIN)
		1-125 MHz	1-40 MHz	60 MHz	100 MHz	1-10 MHz	30-60 MHz	60-100 MHz	1-10 MHz	
JC0-0131NL (2X4)	-0.8	-20	-17	-14	-40	-35	-30	-50	-40	2250
JC0-0132NL (2X6)	-0.8	-20	-17	-14	-40	-35	-30	-50	-40	2250
JC0-0133NL (2X8)	-0.8	-20	-17	-14	-40	-35	-30	-50	-40	2250

### RJ45 Durability Testing Rating

Part Number	Mating Force (MAX)	Unmating Force (MAX)	Durability	Plug to Jack Retention (MIN)
JC Series	5 lbs / 2.268 kgs	5 lbs / 2.268 kgs	750 Insertions	20 lbs / 9.072 kgs

### RJ45 Material Specification

RoHS Compliant Part Number	Shield		Contact			Housing		
	Material	Finish	Material	Plating Area	Solder Area	Material	Specification	MSL <sup>2</sup>
JC Series	Brass	10-20 μ inches thick nickel over brass	Phosphor Bronze	30 μ inches gold over 30-80 μ inches nickel	Tin matte finish	Thermoplastic	UL 94 V-0	1

Notes: 1. Connector dimensions comply with FCC dimension requirements. 2. MSL = Moisture Sensitivity Level rating from 1 to 5 (highest rating = 1, lowest rating = 5).

**2X4 Mechanicals (No LEDs)**

JC0-0131NL

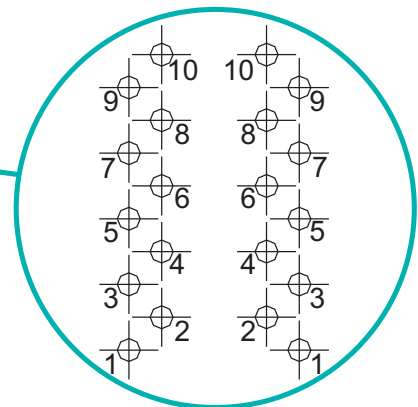
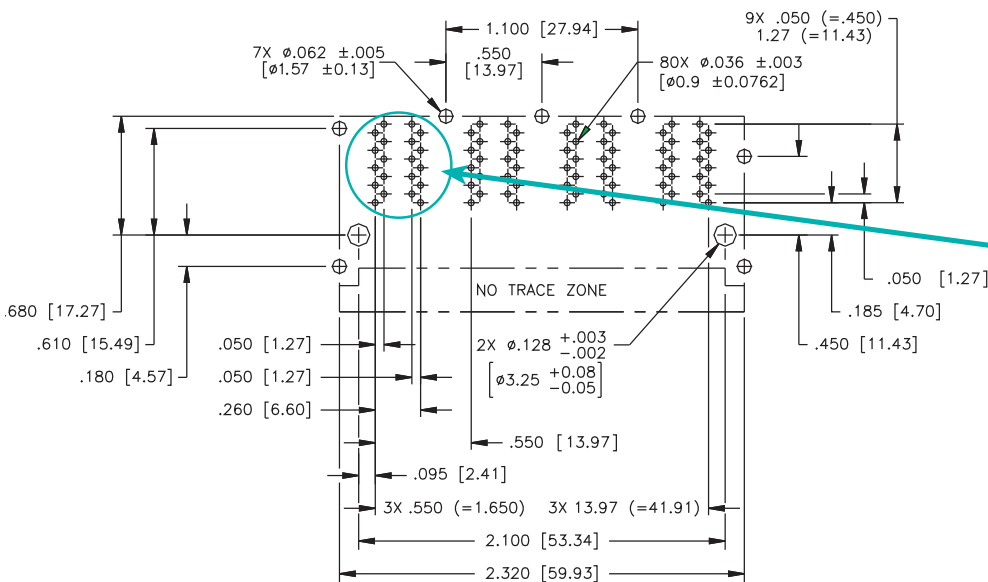
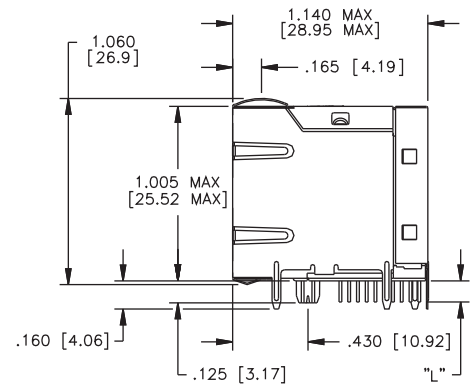
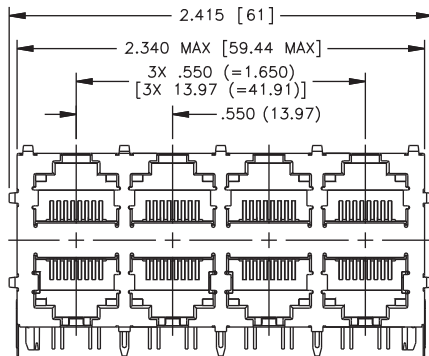
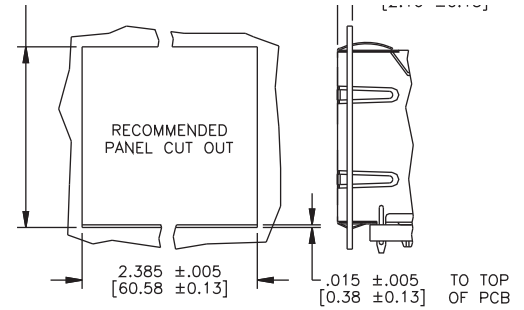
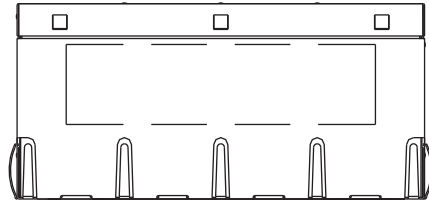

Pin-out Assignment

SUGGESTED PC BOARD LAYOUT VIEWED FROM COMPONENT SIDE  
 UNLESS OTHERWISE SPECIFIED DIMENSIONAL TOLERANCE IS ±.002

**2X6 Mechanicals (No LEDs)**

JC0-0132NL

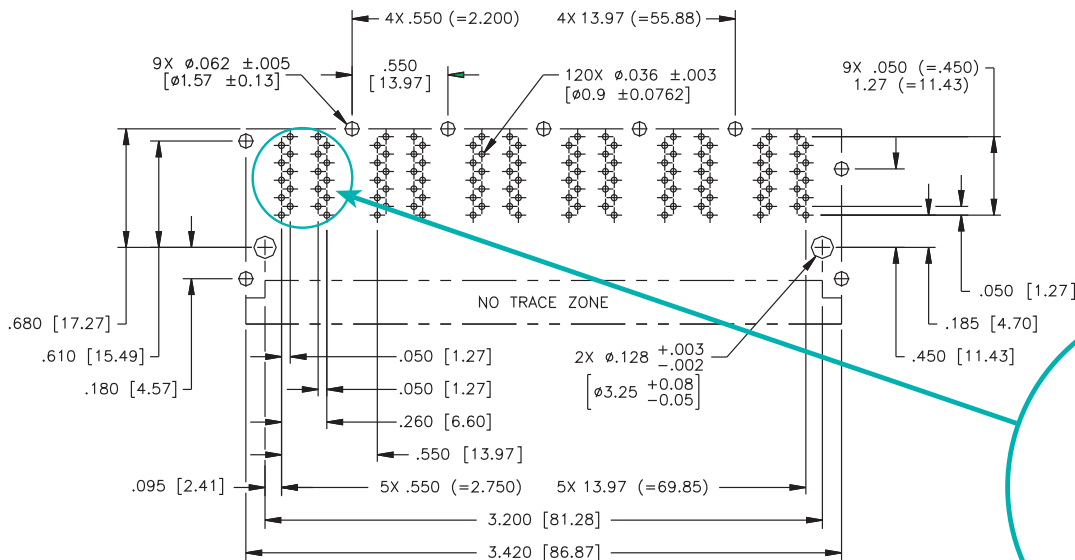
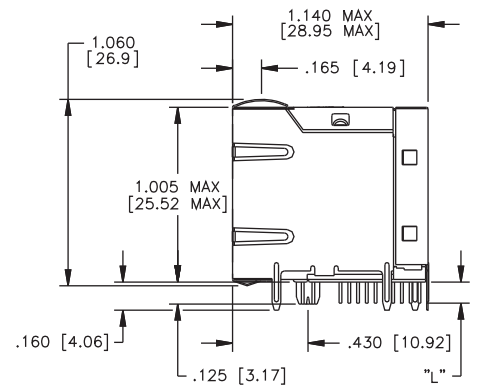
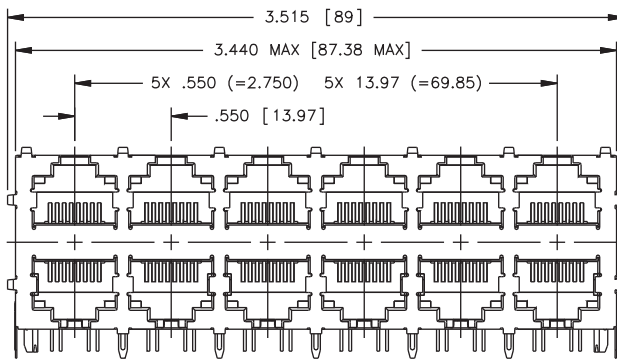
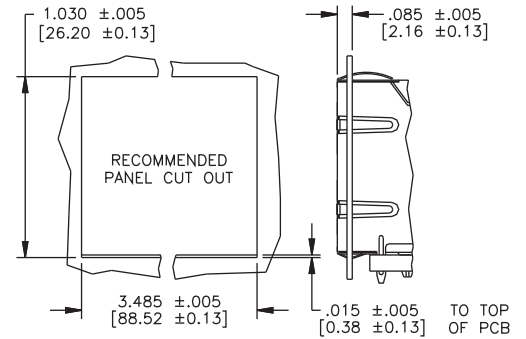
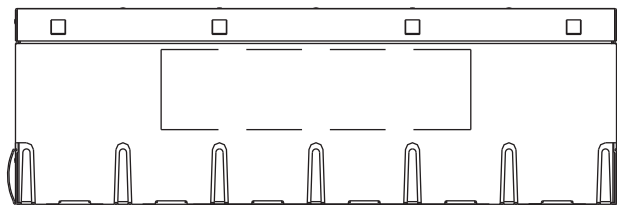

SUGGESTED PC BOARD LAYOUT VIEWED FROM COMPONENT SIDE  
 UNLESS OTHERWISE SPECIFIED DIMENSIONAL TOLERANCE IS ±.002

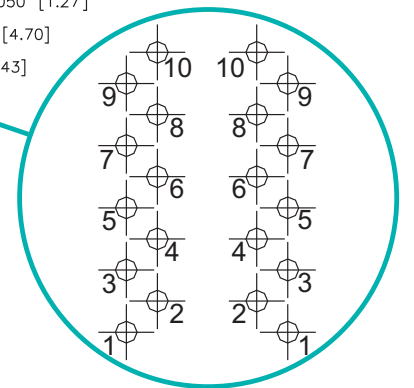

Pin-out Assignment

**2X8 Mechanicals (No LEDs)**

JC0-0133NL

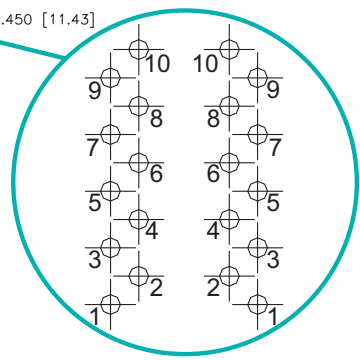
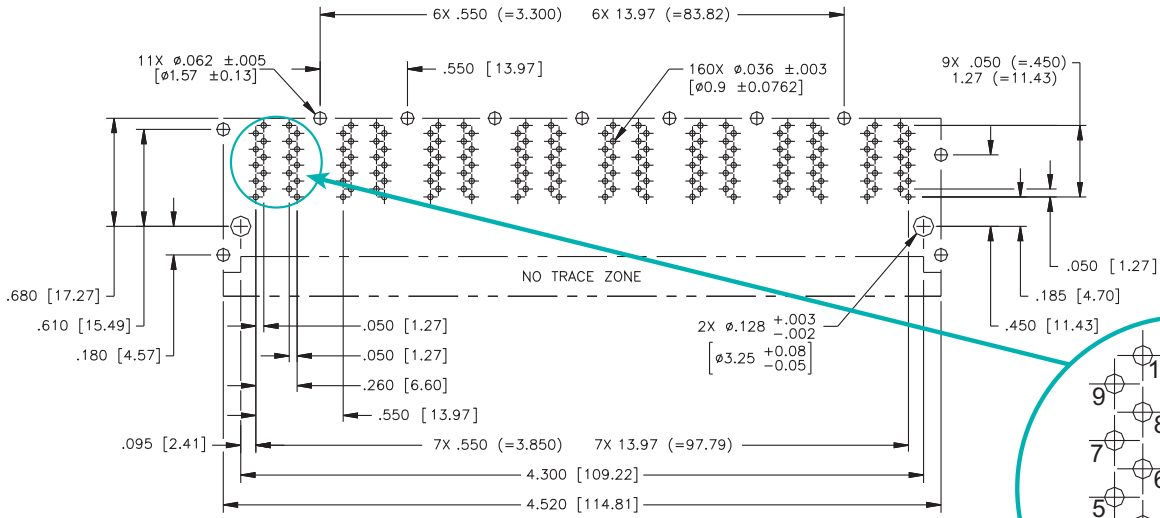
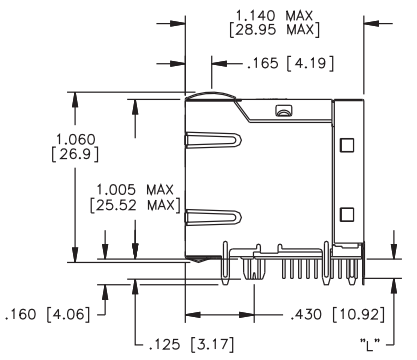
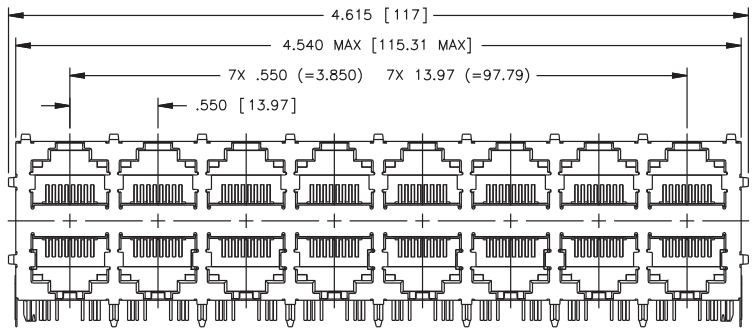
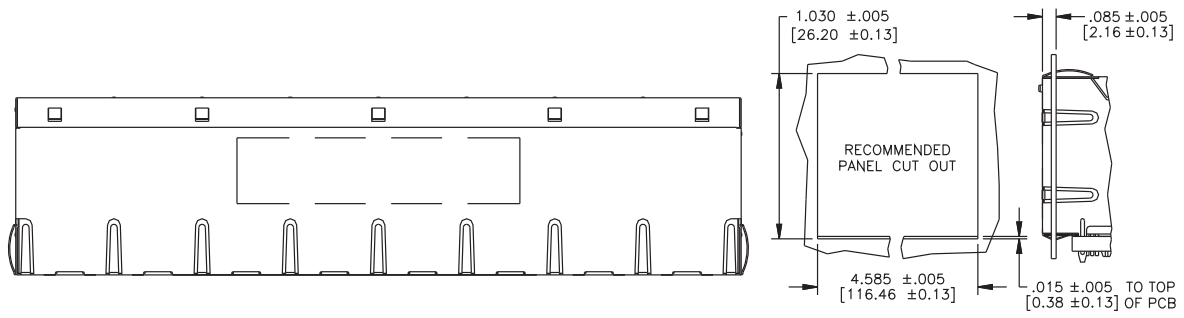

Pin-out Assignment

**Pin-out Assignment**

**JC0-0131NL/32NL/33NL**

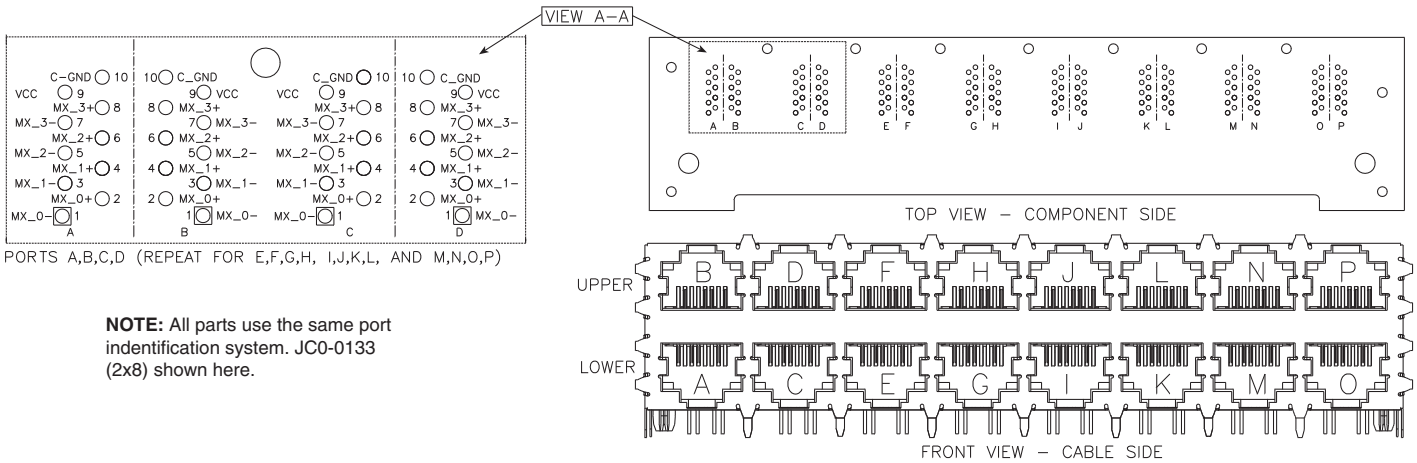

**Schematic**

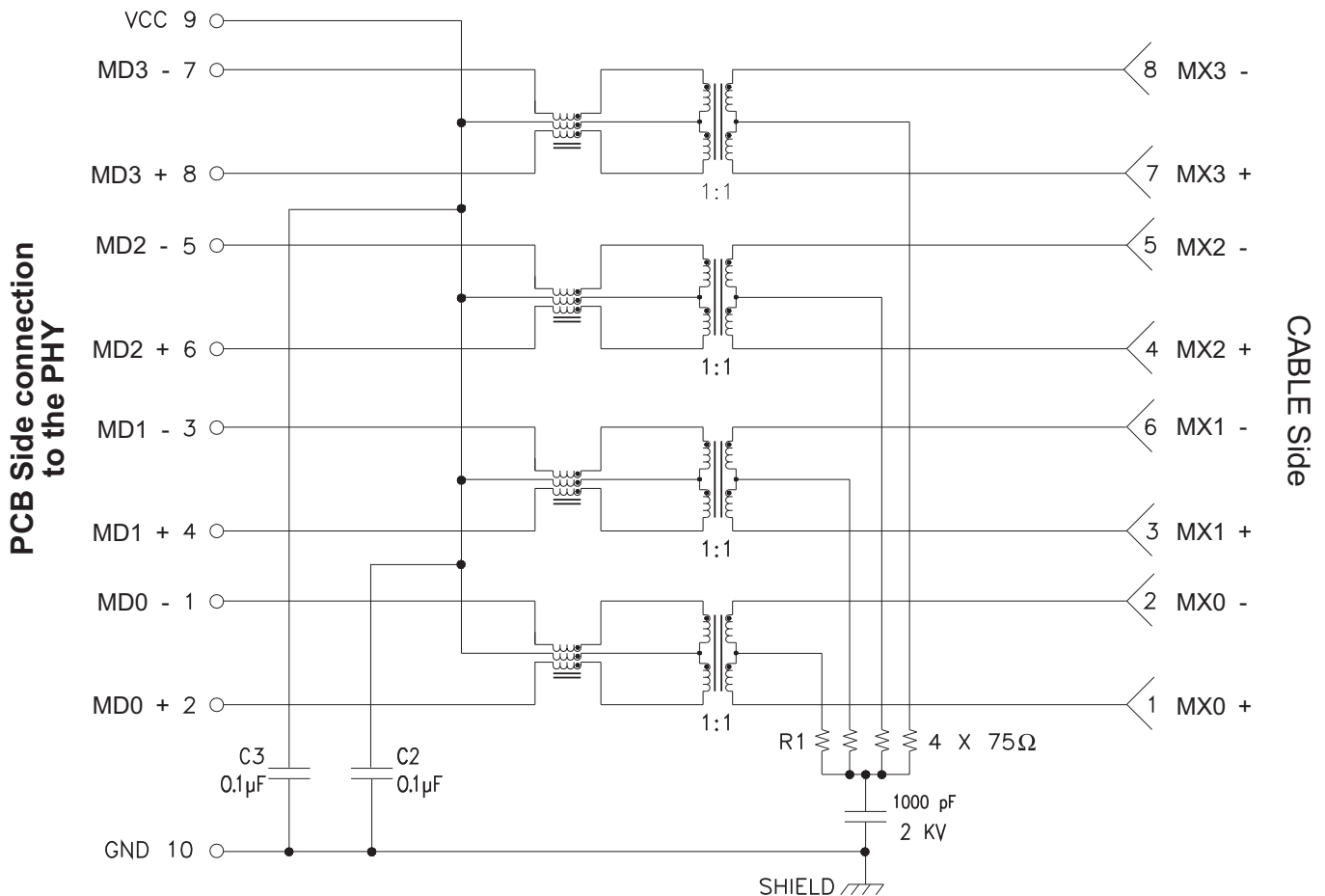

## 2XN Gigstack Application Note

These Integrated Connector Modules are specifically designed for the implementation of a 10Base-T, 100Base-TX and 1000Base-TX transmission over data-grade unshielded twisted pair cable (UTP-3, 5/5e and 6).

The connectors category provide excellent EMI filtering and are suitable for Embedded Systems and Multipoint Applications. Pulse has worked closely with the leading IC manufacturers in providing these 10/100/1000 solutions, thereby assuring compatibility with each transceiver.

JC0 series meet the stringent open circuit inductance requirements imposed by IEEE. When an 8mA DC current is applied across the transformer windings, the transformer will provide at least 350  $\mu$ H of open circuit inductance. The transformers used in each module also provide 2250Vdc minimum isolation, wide bandwidth with minimal attenuation and fast rise times to minimize system level jitter.

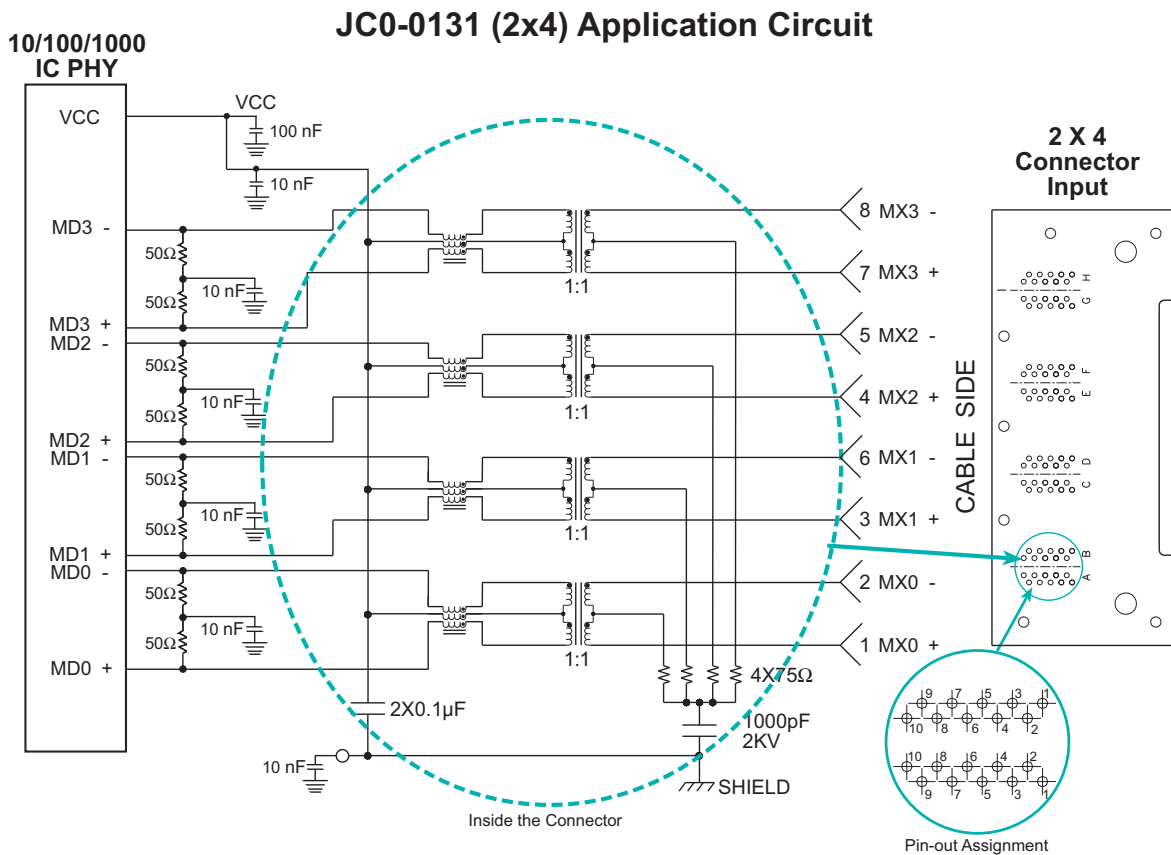

### PCB Layout Recommendations:

- For maximum EMI suppression (electromagnetic interference) place the decoupling capacitors adjacent to Vcc and 50  $\Omega$  connections.
- Connections to ground should be as short as possible.
- Connections between the 10/100/1000 IC and the connector should be direct (ideally no change in direction) and of minimum length.

### For More Information:

#### Pulse Worldwide Headquarters

12220 World Trade Dr.  
 San Diego, CA 92128  
 U.S.A.

[www.pulseeng.com](http://www.pulseeng.com)

Tel: 858 674 8100  
 Fax: 858 674 8262

#### Pulse Europe

Einsteinstrasse 1  
 D-71083 Herrenberg  
 Germany

Tel: 49 7032 7806 0

Fax: 49 7032 7806 135

#### Pulse China Headquarters

B402, Shenzhen Academy of  
 Aerospace Technology Bldg.  
 10th Kejian Rd.  
 High-Tech Zone  
 Nanshan District  
 Shenzhen, PR China 518057

Tel: 86 755 33966678

Fax: 86 755 33966700

#### Pulse North China

Room 2704/2705  
 Super Ocean Finance Ctr.  
 2067 Yan An Rd. West  
 Shanghai 200336  
 China

Tel: 86 21 62787060

Fax: 86 2162786973

#### Pulse South Asia

135 Joo Seng Rd.  
 #03-02  
 PM Industrial Bldg.  
 Singapore 368363

Tel: 65 6287 8998

Fax: 65 6287 8998

#### Pulse North Asia

3F, No. 198  
 Zhongyuan Rd.  
 Zhongli City  
 Taoyuan County 320  
 Taiwan R. O. C.

Tel: 886 3 4356768

Fax: FRE 886 3 4356820

Pulse: 886 3 4356823

Performance warranty of products offered on this data sheet is limited to the parameters specified. Data is subject to change without notice. Other brand and product names mentioned herein may be trademarks or registered trademarks of their respective owners.

© Copyright, 2009. Pulse Engineering, Inc. All rights reserved.