

THE INFORMATION CONTAINED HEREIN IS CONSIDERED 'PROPRIETARY' TO BEL FUSE INC. AND SHALL NOT BE COPIED, REPRODUCED OR DISCLOSED WITHOUT THE WRITTEN APPROVAL OF BEL FUSE INC.



PRELIMINARY

LED1 POLARITY			LED2 POLARITY		
PIN 13	PIN 14	COLOR	PIN 15	PIN 16	COLOR
-	+	GREEN	-	+	GREEN

ELECTRICAL CHARACTERISTICS @ 25°C

URNS RATIO	
TP1	1CT : 1CT ±2%
TP2	1CT : 1CT ±2%
TP3	1CT : 1CT ±2%
TP4	1CT : 1CT ±2%
DCL @ 100kHz/100mVRMS	
8mA DC BIAS	350µH MIN.
INS. LOSS	
0.1MHz TO 1MHz	-1.1 dB MAX
1MHz TO 65MHz	-0.5 dB MAX
65MHz TO 100MHz	-0.8 dB MAX
100MHz TO 125MHz	-1.2 dB MAX
RET. LOSS (MIN)	
0.5MHz-40MHz	-18 dB
40MHz-100MHz	-12+20LOG(f/80MHz) dB
CROSS TALK	
100kHz - 100MHz	-33+20LOG(f/100MHz)dB MIN
CM TO CM REJ	
100kHz - 100MHz	-30 dB MIN
CM TO DM REJ	
100kHz - 100MHz	-35 dB MIN
HIPOT (Isolation Voltage):	
	1500 Vrms
LED 1 & 2	
VF (FORWARD VOLTAGE)	IF=20mA GREEN 2.2V TYP.
λD (DOMINANT WAVELENGTH)	IF=20mA GREEN 565nm TYP.

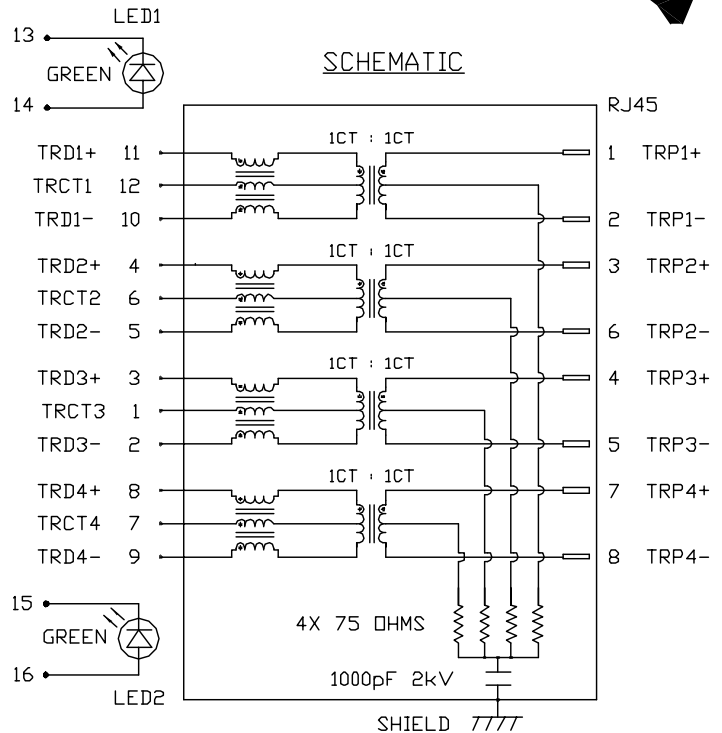

DRWN DE	DATE 01-25-05
CHKD CHUNG	DATE 01-25-05

TITLE glgabit MagJack® (Enhanced EMI, Tab Up)
--

PART NO. / DRAWING NO. 08261G1T63-F
FILE NAME 08261G1T63-FPA.DWG

STANDARD DIM. TOL. IN INCH	[] METRIC DIM. AS REFERENCE
.X	UNIT : INCH [mm]
.XX	SCALE : N/A
.XXX	SIZE : A4
	REV. : PA
	SIZE : A4
	PAGE : 2



FORM NO. - ENG02082001

THE INFORMATION CONTAINED HEREIN IS CONSIDERED 'PROPRIETARY' TO BEL FUSE INC. AND SHALL NOT BE COPIED, REPRODUCED OR DISCLOSED WITHOUT THE WRITTEN APPROVAL OF BEL FUSE INC.

MECHANICAL SPECIFICATION

PRELIMINARY



RECOMMENDED PCB FOOTPRINT
COMPONENT SIDE VIEW

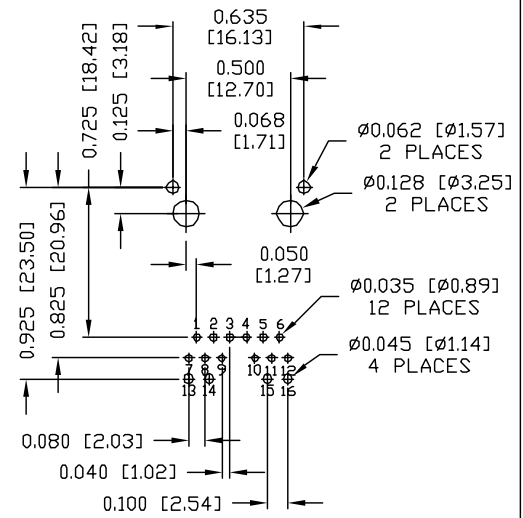
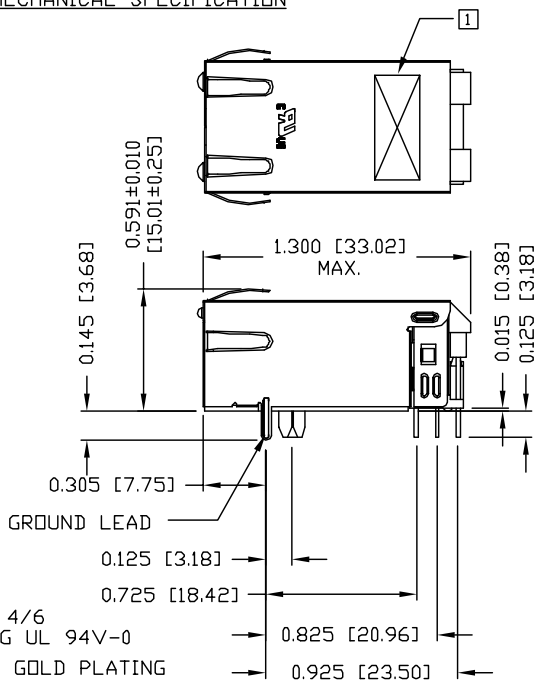
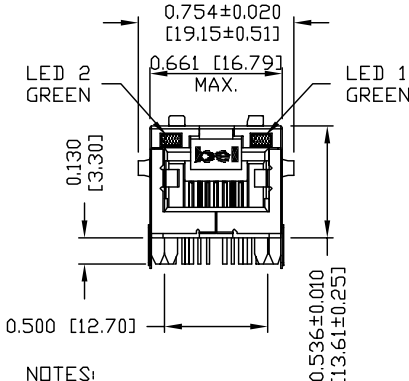

- NOTES:**
 PLASTIC HOUSING: THERMOPLASTIC PA 4/6
 FLAMMABILITY RATING UL 94V-0
 CONTACTS: 50 MICRO-INCH HARD GOLD PLATING
 OUTPUT PINS: TIN-COATED COPPER WIRE, DIA 0.018 INCH.
 METAL SHIELD: NICKEL OR TIN PLATED ON COPPER ALLOY.
 (ALL NICKEL PLATED GROUND LEADS ARE SOLDER DIPPED)
 1. MARK PART WITH MFG LOGO, MFG NAME, PART NUMBER, AND DATE CODE.

UL US UL RECOGNIZED - FILE #E196366 AND E169987.
 2. RoHS COMPLIANCE, PER EU DIRECTIVE 2002/95/EC.

DRWN	DATE	TITLE
LING	01-25-05	gigabit MagJack®
CHKD	DATE	(12 cores, Tab Up)
BILL/KEUNG	01-25-05	0826-1G1T-63-F

PART NO. / DRAWING NO.	FILE NAME
08261G1T63-F	08261G1T63-FPA.DWG

STANDARD DIM.	[] METRIC DIM. AS REFERENCE	
TOL. IN INCH	UNIT : INCH [mm]	REV. : PA
.X	SCALE : N/A	SIZE : A4
.XX		PAGE : 3
.XXX		

FORM NO. - ENG02082001



THE INFORMATION CONTAINED HEREIN IS CONSIDERED "PROPRIETARY" TO BEL FUSE INC. AND SHALL NOT BE COPIED, REPRODUCED OR DISCLOSED WITHOUT THE WRITTEN APPROVAL OF BEL FUSE INC.

PRELIMINARY



SUGGESTED PANEL OPENING

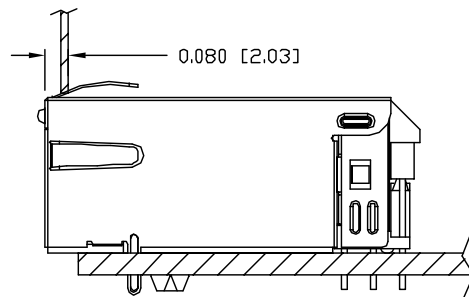
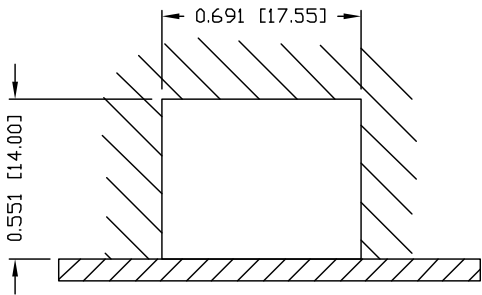

NOTE:

THE DISTANCE OF PANEL INSIDE SURFACE RELATIVE TO FRONT SURFACE OF PART IS ONLY A SUGGESTION. IN CASE THIS DISTANCE IS DIFFERENT, THE REQUIRED PANEL OPENING DIMENSIONS CHANGE ACCORDINGLY.

PACKING INFORMATION

PACKING TRAY : 0200-9999-F6 (TOP)
0200-9999-F7 (BOTTOM)

PACKING QUANTITY : 40 PCS FINISHED GOODS PER TRAY
10 TRAYS (400 PCS FINISHED GOODS) PER CARTON BOX

NOTE : CARDBOARDS ARE PLACED BETWEEN LAYERS OF PACKING TRAY INSIDE CARTON BOX
(INCLUDE THE UPPERMOST AND LOWERMOST TRAY)

DRWN LING	DATE 01-25-05	TITLE glgabit MagJack® (12 cores, Tab Up)	PART NO. / DRAWING NO. 08261G1T63-F	STANDARD DIM. TOL. IN INCH .X .XX .XXX ±0.010	[] METRIC DIM. AS REFERENCE UNIT : INCH [mm] SCALE : N/A	REV. : PA SIZE : A4 PAGE : 4	COMPONENTS FOR PLANETS
CHKD BILL/KEUNG	DATE 01-25-05		FILE NAME 08261G1T63-FPA.DWG				

FORM NO. - ENG02082001