

4

3

2

1

THIS DRAWING IS UNPUBLISHED.
 © COPYRIGHT 19 BY AMP INCORPORATED. ALL RIGHTS RESERVED.

| LOC | DATE | REV | DESCRIPTION | DATE | BY | APP'D |
|-----|------|-----|----------------------|---------|----|-------|
| AA | 22 | D | REV, EC 0502-0377-97 | 22AUG97 | DS | JT |

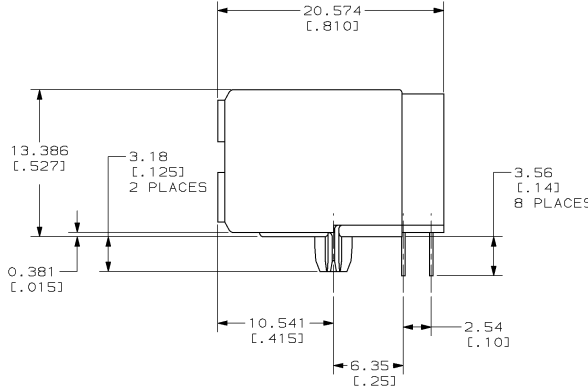
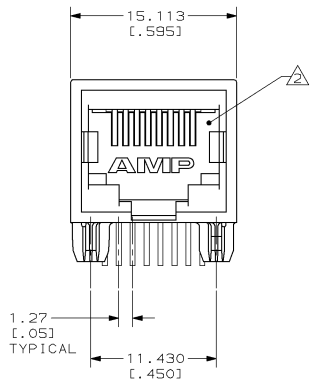

- △ MATERIAL: HOUSING-HTN NYLON, BLACK, IR COMPATIBLE, UL 94V-0. TERMINALS - 0.33[.013] THICK PHOS BRONZE PLATED WITH 1.27µm[.000050] MINIMUM THICK HARD GOLD IN LOCALIZED AREA AND 3.81µm[.000150] MINIMUM THICK TIN-LEAD IN SOLDER AREA OVER 1.27µm[.000050] MINIMUM THICK NICKEL UNDERPLATE.
- △ JACK CAVITY CONFORMS TO FCC RULES AND REGULATIONS, PART 68 SUBPART F.
- 3. ALL DIMENSIONS SHOWN ARE NOMINAL UNLESS OTHERWISE SPECIFIED.
- △ CAUTION: CATEGORY 5 JACK SOLDER TAIL POSITIONS DO NOT FOLLOW SAME NUMBER SEQUENCE AS THAT OF TRADITIONAL JACKS.
- △ USE #30 DRILL BIT OR 3.25mm DRILL BIT WHEN PRODUCING THESE PCB HOLES.

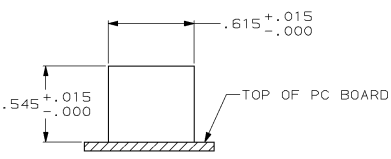
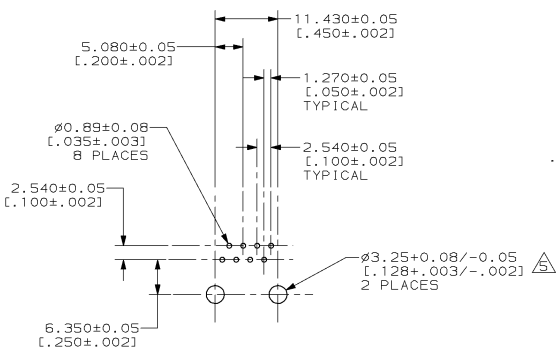

SUGGESTED PANEL CUTOUT
SCALE 2:1

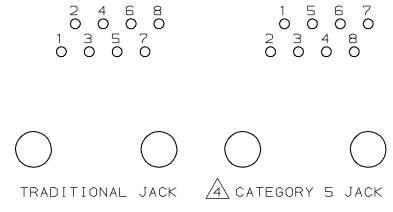

○ TRADITIONAL JACK △ CATEGORY 5 JACK

SUGGESTED PC BOARD LAYOUT
COMPONENT SIDE
SCALE 2:1

| | | | | | | | |
|----------------------------|--|---|--|--|--|--|--|
| DIMENSIONS: mm (INCHES) | | DIMENSIONS SPECIFIED: B PLG ±.001 D PLG ±.001 D PLG ±.001 H PLG ±.001 ANGLES ±.001 | | DIM: T. PITTS 2-2-94 CHK: B. FOX 2-16-94 APP'D: 2-16-94 NAME: | | AMP Incorporated Harrisburg, PA 17105-3608 | |
| MATERIAL: △ | | FINISH: △ | | PRODUCT SPEC: 108-1163 APPLICATION SPEC: 114-2048 WEIGHT: - | | AMP MODULAR JACK ASSEMBLY, 8 POSITION, RIGHT ANGLE, LOW PROFILE, CATEGORY 5 | |
| CUSTOMER DRAWING | | SIZE: A2 CASE CODE: 00779 DRAWING NO: ©-558341 | | SCALE: 4:1 SHEET: 1 OF 1 REV: 0 | | 558341-1 PART NO. | |

AMP 1471-B REV 02/94
 10.15.43 amp33741 /note/amp33741/edmod

558341

558341-1
PART NO.

AMP

AMP Incorporated
Harrisburg, PA 17105-3608

MODULAR JACK ASSEMBLY,
8 POSITION, RIGHT ANGLE,
LOW PROFILE, CATEGORY 5

SIZE: A2
CASE CODE: 00779
DRAWING NO: ©-558341

CUSTOMER DRAWING

SCALE: 4:1
SHEET: 1 OF 1
REV: 0