

D1RFRD006

REVISION RECORD				
REV	ECO	DESCRIPTION	DRFT	CHKD
△		MODIFY DRAWING	ANKUE	12/14/05

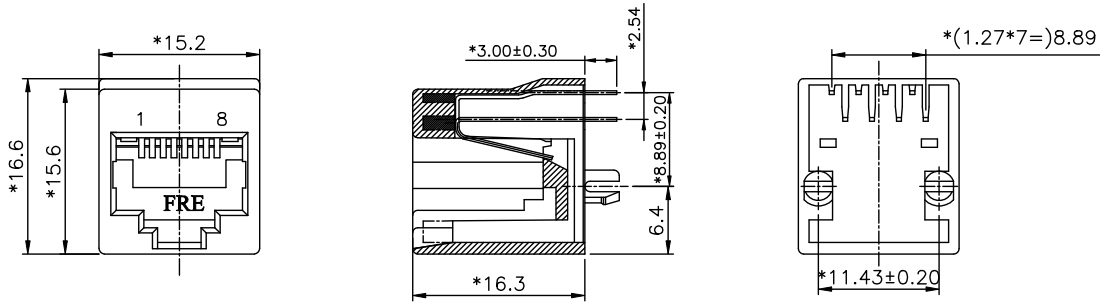

NOTES:

ELECTRICAL:

1. VOLTAGE RATING: 125 VAC RMS .
2. CURRENT RATING: 1.5 AMP .
3. CONTACT RESISTANCE: 30 MILLIOHMS MAX.
4. INSULATION RESISTANCE: 1000 MEGOHMS MIN @ 500 VDC.
5. DIELECTRIC STRENGTH: 1000 VAC RMS 60Hz, 1MIN.

MECHANICAL:

1. HOUSING MATERIAL: FR52 UL94V-0.
HOUSING COLOR: BLACK
2. CONTACT MATERIAL: PHOSPHOR BRONZ t=0.35mm.
3. PLATING: GOLD PLATING OVER NICKEL.
4. OPERATING LIFE: 750 CYCLES MIN.
5. PCB RETENTION PRE-SOLDER: 1 LB MIN.
6. PCB RETENTION POST-SOLDER: 10 LBS MIN.

ENVIRONMENTAL:

1. STORAGE: -40°C TO +85°C.
 2. OPERATION: -40°C TO +85°C.
 3. WAVE SOLDER TEMPERATURE: 255-265°C.(5~10 SECONDS)
- MATES WITH MODULAR PLUG CONFORMING TO
FCC PART 68, SUBPART F.

△RoHS PART NUMBER: E5288-YX0BQX-L

N--W/ FRE LOGO 1--3U" 2--6U" 3--15U"
P--W/O LOGO 4--30U" 5--50U"

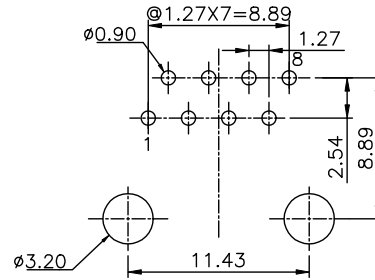

PC Board Layout
Component Side Shown

MM (INCH)		DFTO ANKUE	DATE 08/31/05	FULL RISE ELECTRONIC CO., LTD	
TOLERANCES EXCEPT AS NOTED		CHKD JAMYIN	DATE 2005/12/14	TITLE	
MATERIAL :		MFO	DATE	TOP ENTRY PCB JACK	
ANGLES :		APPV LUSHENG	DATE 2005/12/14	DRAWING NO. GE523048-LA	
THIRD ANGLE PROJECTION		QTY :		/PART NO. SEE NOTE	
		FINISH :		DO NOT SCALE DRAWING	
		SCALE :		SHEET X OF Y	
				SIZE REV	
				A3 1	

8 | 7 | 6 | 5 | 4 | 3 | 2 | 1

H
G
F
E
D
C
B
A