

D1RFRD006

REVISION RECORD				
REV	ECCO	DESCRIPTION	DRFT	CHKD
△		MODIFY DRAWING	ANKUE	12/14/05

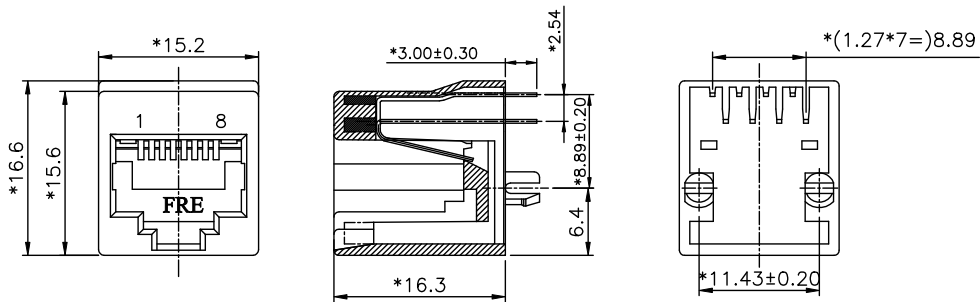

**NOTES:**

**ELECTRICAL:**

1. VOLTAGE RATING: 125 VAC RMS .
2. CURRENT RATING: 1.5 AMP .
3. CONTACT RESISTANCE: 30 MILLIOHMS MAX.
4. INSULATION RESISTANCE: 1000 MEGOHMS MIN @ 500 VDC.
5. DIELECTRIC STRENGTH: 1000 VAC RMS 60Hz, 1MIN.

**MECHANICAL:**

1. HOUSING MATERIAL: GLASS FILLED POLYESTER UL94V-0.
2. CONTACT MATERIAL: PHOSPHOR BRONZ t=0.35mm.
3. PLATING: GOLD PLATING OVER NICKEL.
4. OPERATING LIFE: 750 CYCLES MIN.
5. PCB RETENTION PRE-SOLDER: 1 LB MIN.
6. PCB RETENTION POST-SOLDER: 10 LBS MIN.

**ENVIRONMENTAL:**

1. STORAGE: -40°C TO +85°C.
  - △ 2. OPERATION: -40°C TO +85°C.
  - △ 3. WAVE SOLDER TEMPERATURE: 230°C-250°C.(5~10 SECONDS)
- MATES WITH MODULAR PLUG CONFORMING TO FCC PART 68, SUBPART F.

△RoHS PART NUMBER: E5288-YX0XQX-L

- N--W/ FRE LOGO
- P--W/O LOGO
- 1--3U" 2--6U" 3--15U"
- 4--30U" 5--50U"
- 1--PBT+30%G.F (BLACK)
- F--PBT+30%G.F (WHITE)
- G--PBT+30%G.F (IVORY)
- H--PBT+30%G.F (YELLOW)
- S--PBT+30%G.F (CHINESE RED)

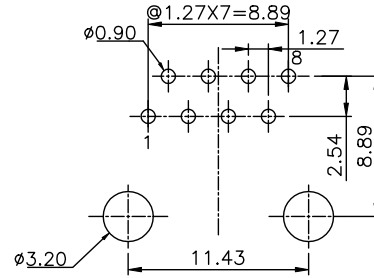

PC Board Layout  
Component Side Shown

MM (MCR)		DFTO ANKUE	DATE 08/31/05	FULL RISE ELECTRONIC CO., LTD	
TOLERANCES EXCEPT AS NOTED		CHKD JAMYIN	DATE 2005/12/14		
DETAILED LISTS		APPV LUSHENG	DATE 2005/12/14	TITLE	
ANGLES *		MATERIAL :		TOP ENTRY PCB JACK	
THIRD ANGLE PROJECTION		QTY :		DRAWING NO. G523048-LC	
		FINISH :		/PART NO. SEE NOTE	
		SCALE :		DO NOT SCALE DRAWING	
				SHEET X	OF Y
				SIZE A3	REV 1

8 | 7 | 6 | 5 | 4 | 3 | 2 | 1

H  
G  
F  
E  
D  
C  
B  
A