

NUMBER C-1734715
METRIC
3RD ANGLE PROJECTION

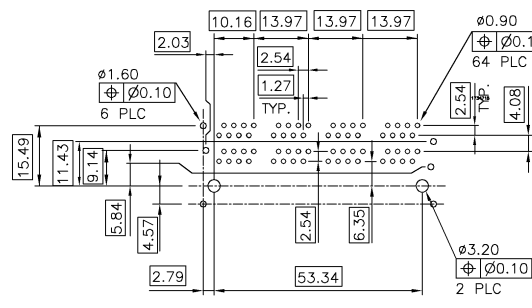
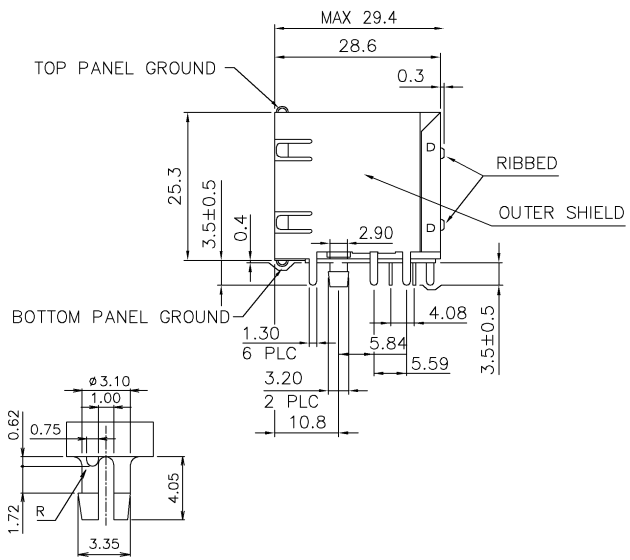
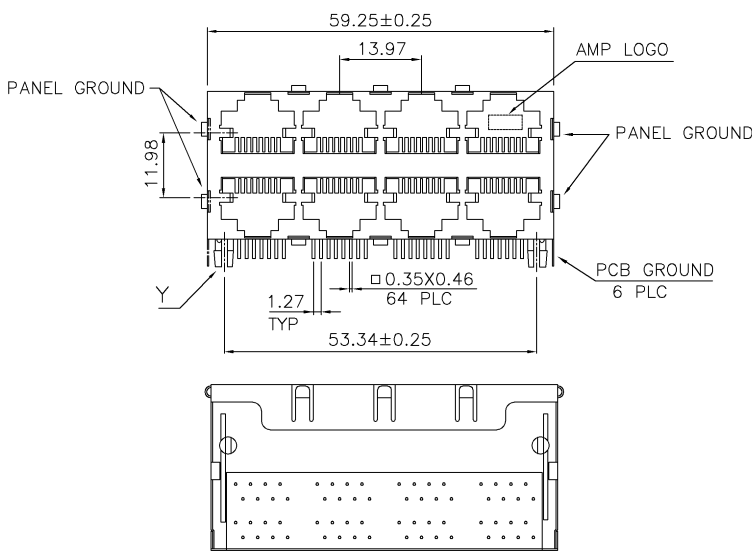

RECOMMENDED PCB LAYOUT (THICKNESS: 1.6mm)
(DIMENSION TOLERANCE: 1 PLC: ±0.1 2PLC: ±0.05)

- NOTE:
- MATERIAL:
HOUSING: THERMOPLASTIC HIGH TEMP., UL94V-0, COLOR: BLACK.
CONTACT: PHOSPHOR BRONZE, THICKNESS: 0.46mm.
SHELL: BRASS, THICKNESS: 0.25mm.
 - FINISH:
CONTACT: GOLD PLATED (SEE TABLE) IN CONTACT AREA,
50µ" MIN. NICKEL UNDER PLATED ALL OVER.
SHELL: 20µ" MIN. NICKEL PLATED.
PCB GROUND: TIN PLATED.
 - REFLOW SOLDER CAPABLE TO 260°C PER TYCO SPEC 109-201,
CONDITION B.

△ OBSOLETE PARTS: OBSOLETE CIS STREAMLINING PER D.RENAUD/D.SINISI

OBSOLETE	TRAY	50µ"	1-1734715-4
		30µ"	1-1734715-3
		15µ"	1-1734715-2
OBSOLETE	TUBE	50µ"	1-1734714-4
		30µ"	1-1734714-3
		15µ"	1-1734714-2

DIMENSION : 0 PLC ± 0.50 1 PLC ± 0.30 2 PLC ± 0.20 3 PLC ± 0.10 ANGLES ± 3°	DWN	O. HU 04-MAY-2005	tyco TYCO HOLDINGS (BERMUDA) VII LTD. TAIWAN BRANCH	
	CHK	S. HOU 04-MAY-2005		
	MATERIAL	APVD	WJ. KE 04-MAY-2005	MODULAR JACK RJ45, MULTI- PORT, SHIELDED, THRU-HOLE, PANEL GROUND
	FINISH	QUALIFICATION TEST REPORT	501-57359	LOC DW A3
SEE NOTE	WEIGHT	50g	SCALE --	
SEE NOTE			DRAWING NO C-1734715	
			SHEET 1 OF 3	

01	REVISED PER ECO-10-000445				
0	FIRST RELEASED				
LTR	REVISION RECORD	ECN			

PRINT DW

NUMBER C-1734715
 3RD ANGLE PROJECTION
 METRIC

PRINT DIST
 DW

THIS INFORMATION IS CONFIDENTIAL AND IS DISCLOSED TO YOU ON CONDITION THAT NO FURTHER DISCLOSURE IS MADE BY YOU TO OTHER THAN AMP PERSONNEL WITHOUT DIMENSIONS IN MILLIMETERS. DO NOT SCALE PRINT.

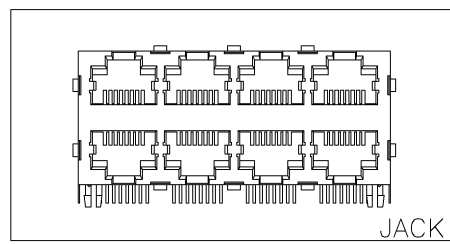
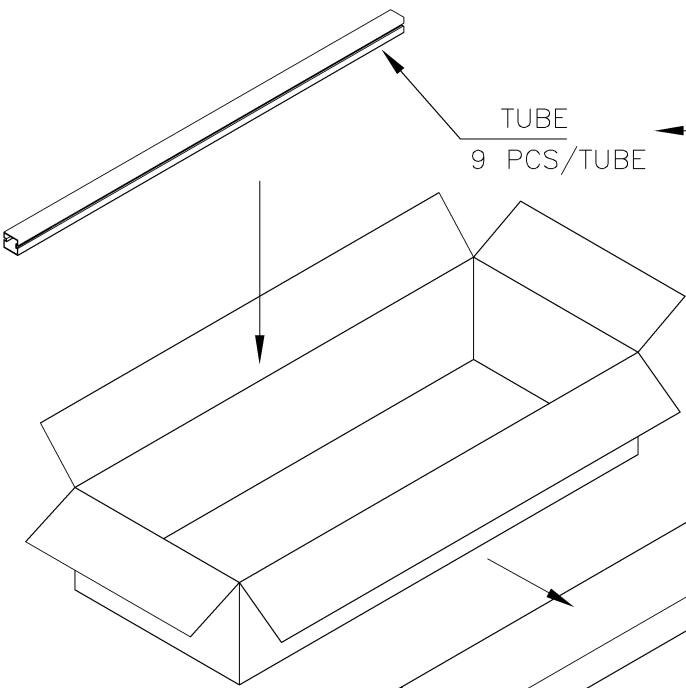

CARTON
 630mm(L)X260mm(W)X180mm(H)
 25 TUBE/CARTON
 TOTAL: 225 PCS
 NET WEIGHT: 11.25Kg Ref.
 GROSS WEIGHT: 12.25Kg Ref.

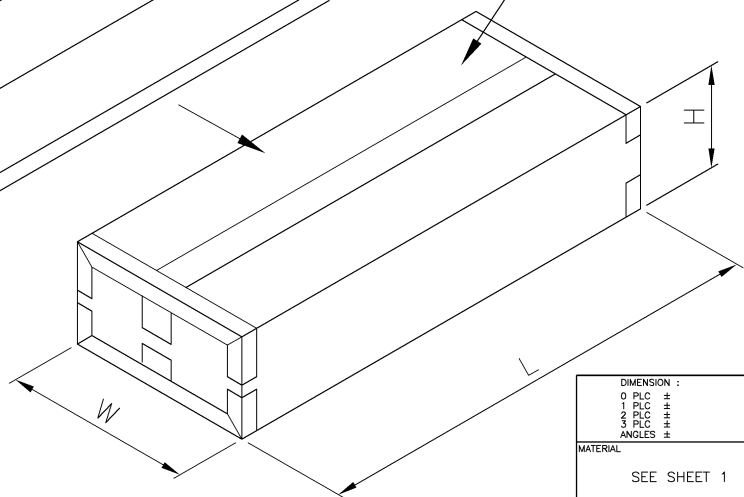

SEE SHEET 1	ECN	DWN/CHK	DATE
LTR	REVISION RECORD		

DIMENSION :	DWN	O. HU	tyco	TYCO HOLDINGS (BERMUDA)
0 PLC ±		04-MAY-2005	Electronics	VII LTD. TAIWAN BRANCH
1 PLC ±	CHK	S. HOU	NAME	
2 PLC ±		04-MAY-2005		
3 PLC ±				
ANGLES ±				
MATERIAL	APVD	WJ. KE	MODULAR JACK RJ45, MULTI-PORT, SHIELDED, THRU-HOLE, PANEL GROUND	
SEE SHEET 1		04-MAY-2005	LOC	SIZE
FINISH	APPLICATION SPEC		DW	DRAWING NO
SEE SHEET 1			A ₃	C-1734715
	WEIGHT		SCALE	REV
			--	O1
				SHEET
				2 OF 3

CUSTOMER DRAWING

NUMBER C-1734715
 3RD ANGLE PROJECTION
 METRIC

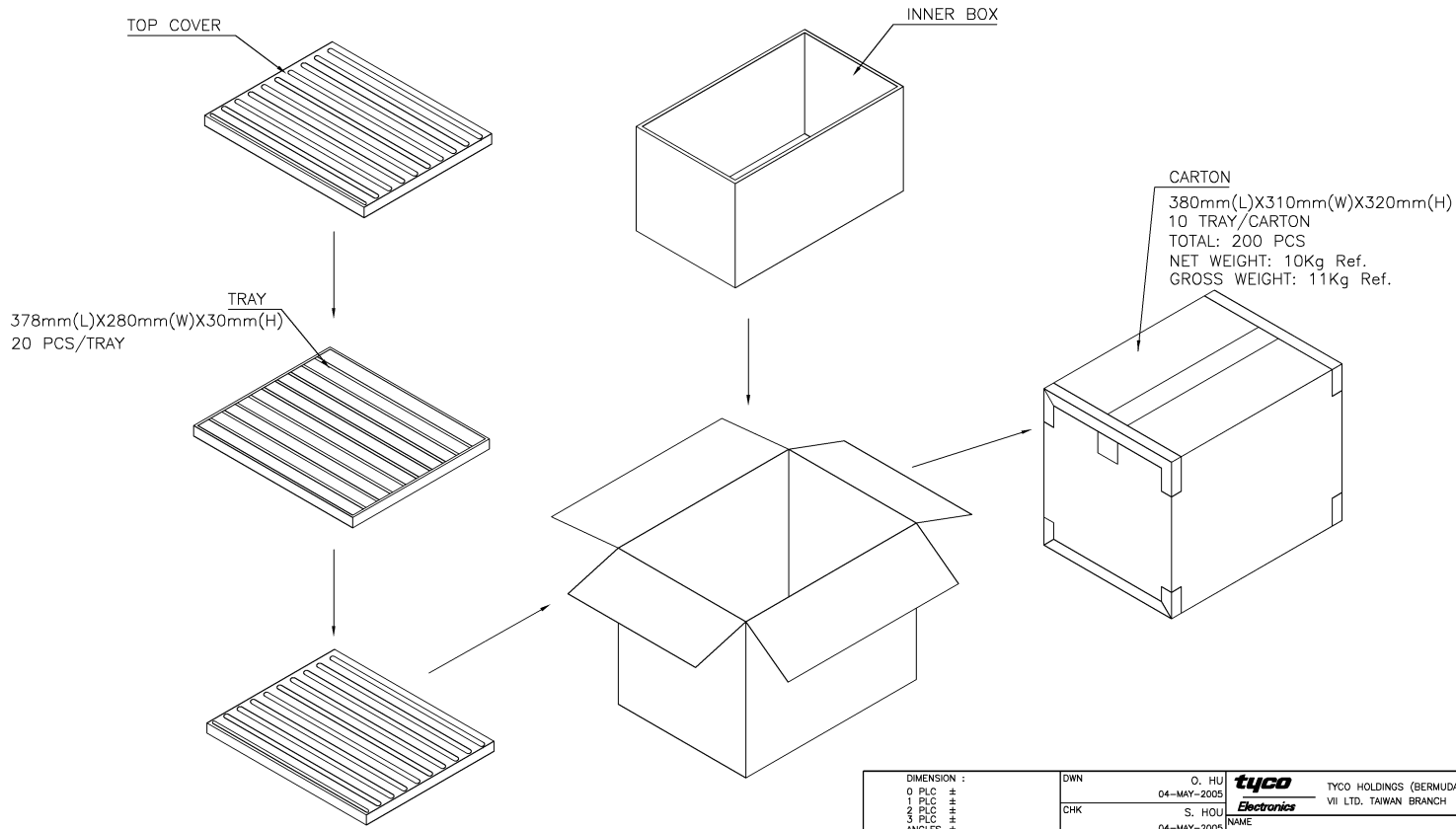

THIS INFORMATION IS CONFIDENTIAL AND IS DISCLOSED TO YOU ON CONDITION THAT NO FURTHER DISCLOSURE IS MADE BY YOU TO OTHER THAN AMP PERSONNEL WITHOUT DIMENSIONS IN MILLIMETERS. DO NOT SCALE PRINT.

PRINT DW

SEE SHEET 1	ECN	DWN/CHK	DATE
LTR	REVISION RECORD		

DIMENSION :	DWN	O. HU	tyco	TYCO HOLDINGS (BERMUDA)
0 PLC ±		04-MAY-2005	Electronics	VII LTD. TAIWAN BRANCH
1 PLC ±	CHK	S. HOU	NAME	
2 PLC ±		04-MAY-2005		
3 PLC ±				
ANGLES ±				
MATERIAL	APVD	WJ. KE	MODULAR JACK RJ45, MULTI-PORT, SHIELDED, THRU-HOLE, PANEL GROUND	
SEE SHEET 1		04-MAY-2005		
FINISH	APPLICATION SPEC		LOC	SIZE
SEE SHEET 1			DW	A ₃
	WEIGHT		DRAWING NO	REV
			C-1734715	O1
			SCALE	SHEET
			--	3 OF 3

CUSTOMER DRAWING