

DRAWING MADE IN THIRD ANGLE PROJECTION

THIS DRAWING IS UNPUBLISHED. RELEASED FOR PUBLICATION 19
 © COPYRIGHT 19 BY AMP INCORPORATED, HARRISBURG, PA. ALL INTERNATIONAL RIGHTS RESERVED. AMP PRODUCTS MAY BE COVERED BY U.S. AND FOREIGN PATENTS AND/OR PATENTS PENDING.

LOC AA 22

REVISIONS					
P	F	ZONE/LTR	DESCRIPTION	DATE	APPROVED
		F1	ECO-06-019685	08SEP85	JM BM
		F2	REV ECO-07-025549	19DEC87	LH SA
		F3	REVISED PER ECO-08-031715	13MAY91	REG JGG

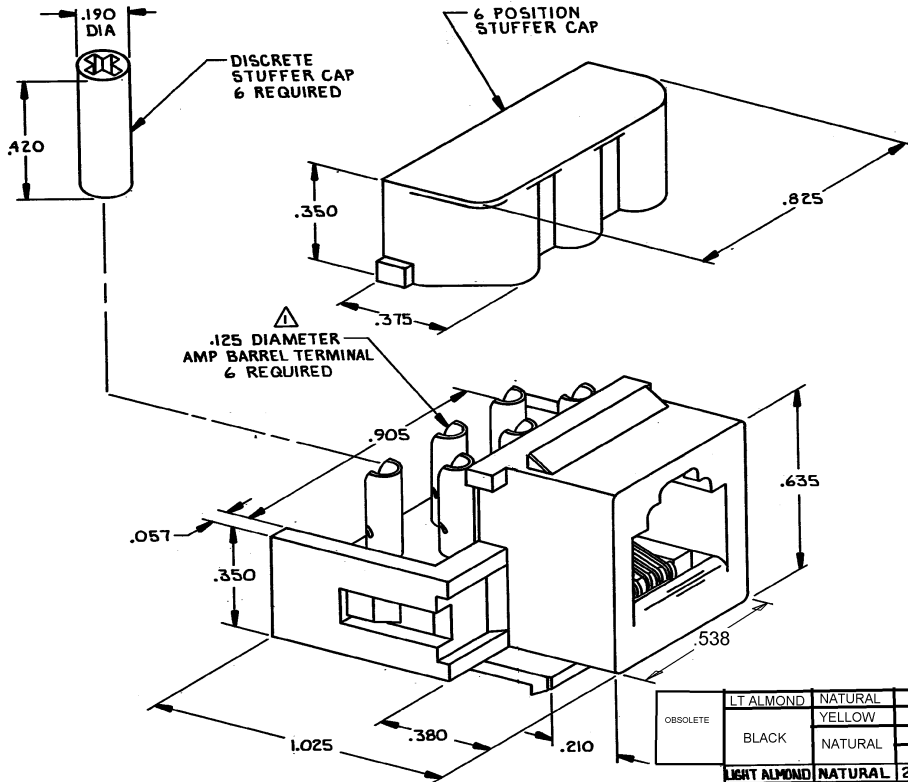

- 1. BARREL TERMINAL WIRE RANGE: 19-28 AWG SOLID OR STRANDED WIRE MAX INSULATION DIA IS .065.
- 2. MOUNTING PANEL THICKNESS: .062 NOMINAL.
- 3. MATERIAL: 6 POSITION STUFFER CAP - POLYCARBONATE, NATURAL. DISCRETE STUFFER CAP - NYLON 6/6. BARREL TERMINAL - TIN COATED PHOSPHOR BRONZE. CONTACTS - NICKEL PLATED HIGH STRENGTH COPPER ALLOY HAVING SELECTIVE GOLD PLATING ON CONTACT AREA AND SELECTIVE TIN PLATING ON BARREL TERMINAL AREA. HOUSING AND KEYSTONE - THERMOPLASTIC, 34 V-0 RATED, SEE TABLE.
- 4. STUFFER CAPS SHIPPED NOT ASSEMBLED.
- 5. BARREL TERMINALS WILL ACCOMODATE ONE OR TWO WIRES OF THE SAME TYPE AND WITHIN PLUS OR MINUS ONE WIRE GAUGE SIZE.

HOUSING COLOR	STUFFER CAP COLOR	WIRE RANGE	DESCRIPTION	PART NO	
OBSOLETE	LT ALMOND	NATURAL	22-26 AWG	KIT WITH 1 SIX POSITION STUFFER CAP	5-554171-4
	BLACK	YELLOW	19-22 AWG	KIT WITH SIX DISCRETE STUFFER CAPS	5-554171-3
		NATURAL	24-28 AWG		5-554171-2
		NATURAL	22-26 AWG	KIT WITH 1 SIX POSITION STUFFER CAP	5-554171-1
	LIGHT ALMOND	NATURAL	22-26 AWG	KIT WITH 1 SIX POSITION STUFFER CAP	-4
OBSOLETE	BLACK	YELLOW	19-22 AWG	KIT WITH 6 DISCRETE STUFFER CAPS	3
OBSOLETE		NATURAL	24-28 AWG		2
		NATURAL	22-26 AWG	KIT WITH 1 SIX POSITION STUFFER CAP	554171-1

UNLESS OTHERWISE SPECIFIED DIMENSIONS ARE IN INCHES.		CONTRACT NO	
TOLERANCES ON:		DR <i>C. Yates</i> 6-20-85	
DECIMALS	± .010	CHK <i>Stacy D. ...</i> 11-85	
ANGLES		APPD <i>W. J. ...</i> 7-1-85	
MATERIAL		AMPD	
FINISH		DSGN APPD	
		OTHER APPD	
AMP INCORPORATED Harrisburg, Pa. 17105		NAME	
KEYSTONE JACK KIT, 6 POSITION, COMMERCIAL		SIZE	
SCALE 4:1		FSCM NO	
DRAWING NO		REV	
554171		F3	
SHEET 1 OF 1		CUSTOMER DRAWING	

INNER PANEL CUTOUT SCALE 2:1

FRONT PANEL CUTOUT SCALE-2:1

WIRING DIAGRAM

554171

CUSTOMER DRAWING