

NUMBER C-1734616

METRIC

THIS INFORMATION IS CONFIDENTIAL AND IS DISCLOSED TO YOU ON CONDITION THAT YOU WILL NOT DISCLOSE IT TO ANY OTHER PERSONS WITHOUT THE WRITTEN APPROVAL OF TYCO ELECTRONICS (TAWAN) LTD. DIMENSIONS IN MILLIMETERS. DO NOT SCALE PRINT.

PRINT DW

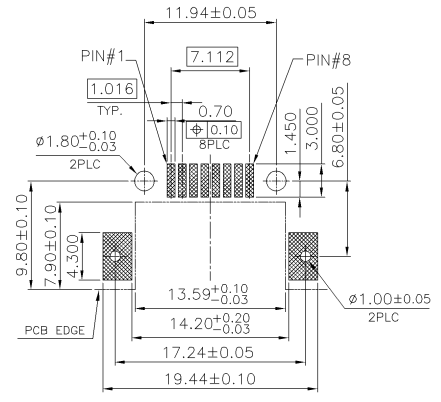
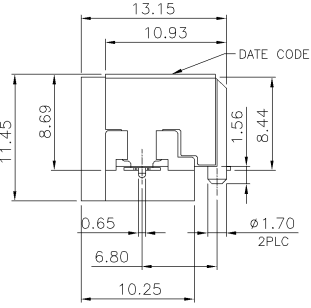
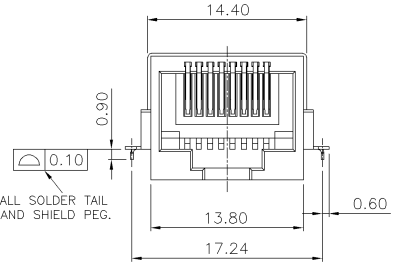

RECOMMENDED PCB LAYOUT
TOLERANCE: ±0.05

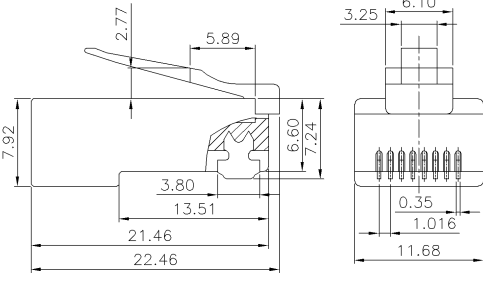
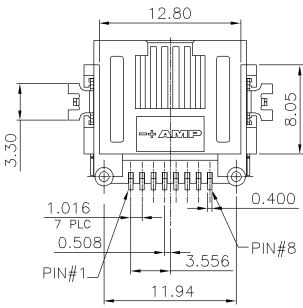

RECOMMENDED 8P PLUG
TOLERANCE ±0.05

- NOTES:
- MATERIAL:
 - HOUSING: THERMOPLASTIC, (LCP), UL94V-0; COLOR:BLACK.
 - CONTACTS: PHOSPHOR BRONZE
 - BOARDLOCK: BRASS
 - FINISH:
 - CONTACT:
 - 0.381μm[15μ"]MIN. GOLD PLATING ON CONTACT AREA.
 - 2.54μm[100μ"]MIN. MATTE TIN PLATING ON SOLDER TAILS, 2.03μm[80μ"]MIN. NICKEL UNDERPLATING OVERALL.
 - SHELL:
 - 0.051μm[2μ"] GOLD PLATING ON SOLDERTAILS, 1.27~2.54μm[50~100μ"]MIN. NICKEL UNDERPLATING OVERALL.
 - RECOMMENDED PCB THICKNESS : 1.2mm
 - REFLOW SOLDER CAPABLE TO 260°C PER TYCO SPEC. 109-201, CONDITION B.

1734616-2
PART NUMBER

TOLERANCES UNLESS OTHERWISE SPECIFIED:	DWN	S. HOU	tyco	TYCO HOLDINGS (BERMUDA)
0 PLC ±0.5		20-APR-2006	Electronics	VII LTD. TAIWAN BRANCH
1 PLC ±0.3	CHK	W.J. KE	NAME	
2 PLC ±0.2		20-APR-2006		
3 PLC ±0.2				
ANGLES ±3°				
MATERIAL	APVD	W.J. KE	MODULAR JACK, RJ45, OFFSET SMT TYPE.	
SEE NOTE	PRODUCT SPEC	20-APR-2006		
	10B-57808			
FINISH	QUALIFICATION TEST REPORT	LDC	SIZE	DRAWING NO
SEE NOTE	501-57814	SCALE	A ₃	C-1734616
	WEIGHT			REV
	2.3 GRAM			B
				SHEET
				1 OF 2

B	REVISED	ECR-06-009181	SH	20APR
A	FIRST RELEASED	--	SH	15MAR
LTR	REVISION RECORD	ECN	DWN	CHK
			DATE	

CUSTOMER DRAWING

NUMBER C-1734616

3RD ANGLE PROJECTION

METRIC

THIS INFORMATION IS CONFIDENTIAL AND IS DISCLOSED TO YOU ON CONDITION THAT YOU WILL NOT DISCLOSE IT TO ANY OTHER PERSONS WITHOUT THE WRITTEN APPROVAL OF TYCO ELECTRONICS (TAWAN) LTD. DIMENSIONS IN MILLIMETERS. DO NOT SCALE PRINT.

PRINT DW

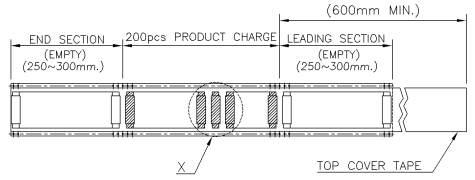
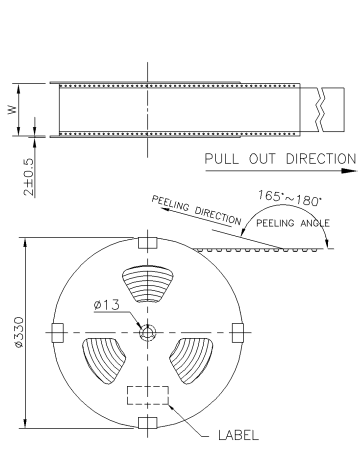

- NOTES:
- MATERIAL :
 - EMBOSSED CARRIER: PS T=0.40±0.05,CLEAR.
 - COVER TAPE: PS
 - SHIPPING CARTON: CORRUGATED FIBER
 - DIMENSION :
 - REEL: W=32.4
 - SHIPPING CARTON: L=335, W=335, H=248(INNER DIM)
 - QUANTITY :
 - PRIMARY PACKING: 200 PCS/REEL
 - SECONDARY PACKING: 5 REELS/CARTON(1000 PCS)
 - WEIGHT :
 - NET WEIGHT: 0.46KG/REEL, 2.3KG/CARTON.
 - GROSS WEIGHT: 0.95KG/REEL, 5.85KG/CARTON.
 - PEELING RESISTANCE: 10.2gf~71.4gf.
 - PEELING SPEED: 300mm/minutes.

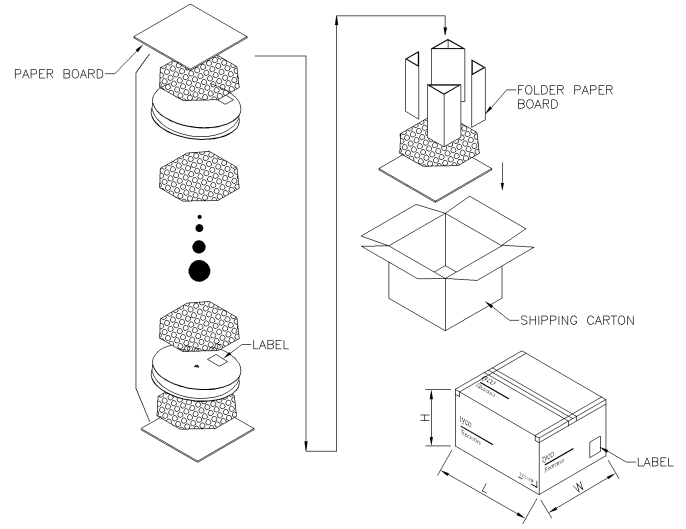
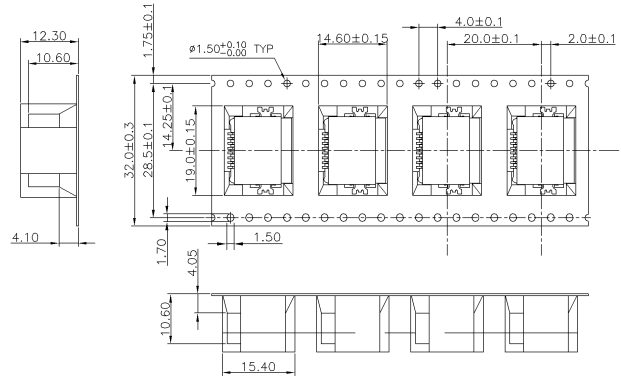

TOLERANCES UNLESS OTHERWISE SPECIFIED: 0 PLC ± 1 PLC ++ 2 PLC +++ 3 PLC ++++ ANGLES ±	DWN S. HOU 20-APR-2006	tyco Electronics TYCO HOLDINGS (BERMUDA) VII LTD. TAIWAN BRANCH
MATERIAL	CHK W.J. KE 20-APR-2006	NAME
FINISH	APVD W.J. KE 20-APR-2006	MODULAR JACK, RJ45, OFFSET SMT TYPE.
WEIGHT	PRODUCT SPEC	LOC DW A3
	APPLICATION SPEC	SCALE
		DRAWING NO. C-1734616
		REV B
		SHEET 2 OF 2

SEE SHEET 1	REVISION RECORD	ECN	DWN	CHK	DATE

CUSTOMER DRAWING