

DO NOT SCALE
DIMENSIONS IN mm

METRIC



NOTES:

- △ BARREL TERMINALS WILL ACCEPT ONE OR TWO WIRES OF THE SAME SIZE PER TERMINAL.
WIRE SIZE FOR SOLID AND STRANDED WIRES:
0,12 mm² (26 AWG)-0,35 mm² (22 AWG).
MAXIMUM INSULATION DIA. 1,2 mm.
- △ STUFFER CAP IS SHIPPED NOT ASSEMBLED.
- △ MATERIALS: STUFFER CAP - A.B.S. UL 94HB
BARREL TERMINALS - PHOS.BRONZE, PRE-TINPLATED.
CONTACTS - PHOS.BRONZE, PLATED 1,25
HOUSING - PBT, UL 94HB
- △ FOR 216000-2 DIMENSION 15,2 IS 14,6 ,
CORRESPONDING WITH THE MARKED DASH LINES
- △ NO STUFFER CAP INCLUDED

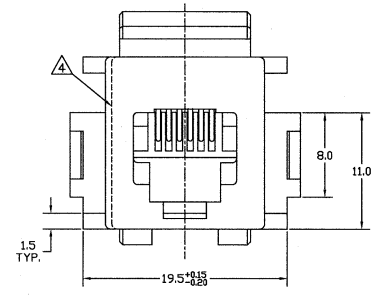
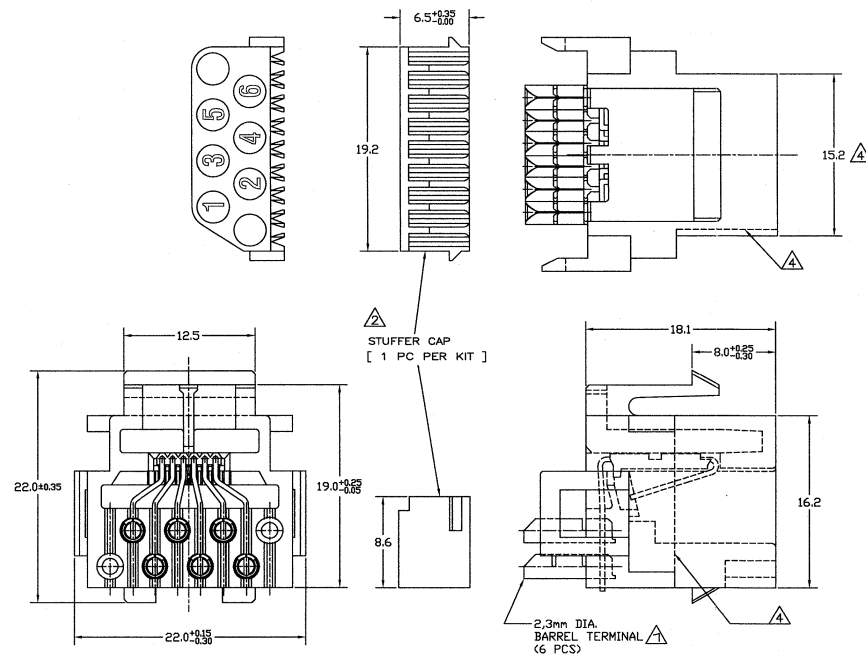

SUGGESTED PANEL CUTOUT DIMENSIONS

SCALE 2 : 1

X-216000-1

X-216000-2, -3 AND -5

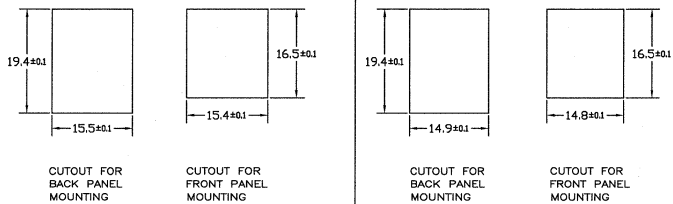

PANEL THICKNESS: 1,6 mm NOMINAL

TOLERANCE: ±0,15 UNLESS SPECIFIED OTHERWISE

OBSOLETE

500 PCS. IN A BOX	SEE NOTE △	HOUSING COLOR: BLACK SEE NOTE △	△ 216000-2 216000-1
PACKAGING	FINISH	MATERIAL	PARTNUMBER
R1 ECR-08-012358	AEG - 29-01-09	CUSTOMER DRAWING	FOR REFERENCE ONLY WILL NOT BE UPDATED.
R D901-0880-03	PW P6 25 JUL 03	© COPYRIGHT 19 BY AMP HOLLAND B.V.	
P SR10-0119-01	KV KV 23 APR 01	ALL INTERNATIONAL RIGHTS RESERVED. AMP PRODUCTS MAY BE COVERED BY U.S. AND FOREIGN AND/OR PATENTS PENDING.	
NI SR10-0048-01	KV KV 29 FEB 01	THIS DRAWING IS UNPUBLISHED RELEASED FOR PUBLICATION	
N H-8282	J.T. J.T. 10 OCT 94	Tyco Electronics	Tyco Electronics Corporation Oostkamp - BELGIUM
M H-8282	J.T. J.T. 22 OCT 93	NAME	
L H-8282	J.T. J.T. 16 JUN 93	TOOLLESS MODULAR JACK KIT	
LTR REVISION RECORD	DR. CHK. DATE	8 POS., FOR DISCRETE WIRES	
DR.: J.VLEKMT	CHK.: W.BRAMMANS	APP.: L. V. SKEST	DWG. No. C-216000
DATE: 21 JAN 91	DATE:	DATE: 12 OCT 94	REV. LTR. SHEET R1 1 OF 1 A2