

4

3

2

1

THIS DRAWING IS UNPUBLISHED. RELEASED FOR PUBLICATION
 © COPYRIGHT - BY TYCO ELECTRONICS CORPORATION. ALL RIGHTS RESERVED.

LOC	DIST	REVISIONS					
DW	-	P	LTR	DESCRIPTION	DATE	DWN	APVD
				SEE SHEET 1.			

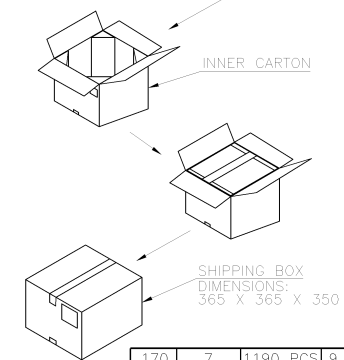
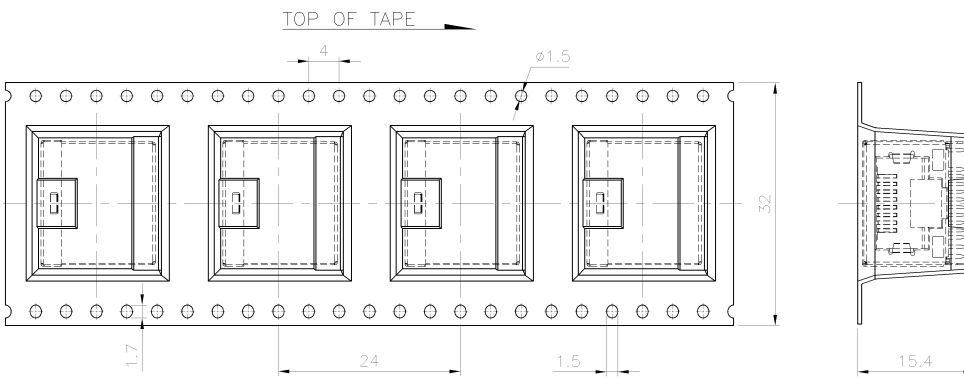
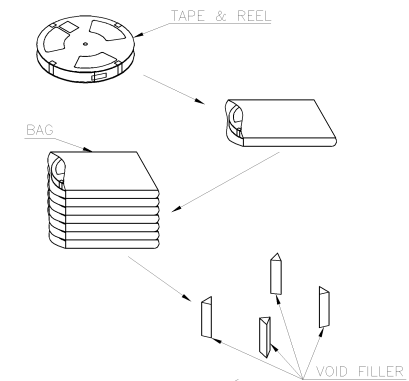
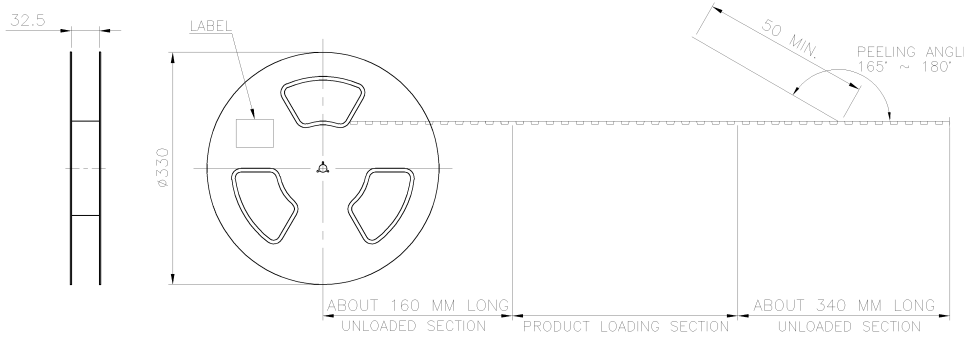

170	7	1190 PCS	9.3 KG	4.72 KG
PCS/TAPE	REELS/BOX	QUANTITY	GROSS WEIGHT	NET WEIGHT

- 1. PEELING STRENGTH: 0.1 ~ 1.3 N (10 ~ 130 GRAMS)
- 2. PEELING SPEED: 300 mm/min.

THIS DRAWING IS A CONTROLLED DOCUMENT.		DWN	A. WU	24MAR2008	Tyco Electronics Corporation Taipei, Taiwan		
DIMENSIONS: MM		CHK	S. HOU	24MAR2008			
TOLERANCES UNLESS OTHERWISE SPECIFIED:		APVD	W. KODAMA	24MAR2008			
0 PLC ± - 1 PLC ± - 2 PLC ± - 3 PLC ± - 4 PLC ± - ANGLES ± -		NAME		MODULAR JACK ASSEMBLY, 1X1, SHIELDED, LED, TAB DOWN			
MATERIAL		PRODUCT SPEC		SIZE	CAGE CODE	DRAWING NO	RESTRICTED TO
FINISH		APPLICATION SPEC		A3	00779	C=1775553	-
		WEIGHT		CUSTOMER DRAWING		SCALE	SHEET
						-	2 of 2
							REV
							A