

RECOMMENDED PCB LAYOUT (THICKNESS: 1.6MM)
(DIMENSION TOLERANCE: 1 PLC: ±0.1, 2 PLC: ±0.05)

- NOTE:
- MATERIAL:
HOUSING: HIGH THERMOPLASTIC, UL94V-0, COLOR: BLACK.
CONTACT: PHOSPHOR BRONZE, THICKNESS: 0.35mm.
SHELL: BRASS, THICKNESS: 0.25mm.
LED LIGHT: EPOXY RESIN, THICKNESS: 0.50mm.
 - FINISH:
CONTACT: GOLD PLATED (SEE TABLE) IN CONTACT AREA, GOLD FLASH ON SOLDER TAILS, 50u" MIN. NICKEL UNDER PLATED ALL OVER.
SHIELD: 20u" MIN NICKEL PLATED.
LED LIGHT: 65u" MIN. Ag PLATED.
80u" MIN. TIN PLATED.
 - LED MUST BE REFLOW COMPATIBLE TO FOLLOWING TEMPERATURE PROFILE (FOR 1 CYCLE): ABOVE 160°C FOR 120 SECONDS, PEAKING AT 230°C FOR 6~8 SECONDS.
 - LED DEFECT RATE IS 6000 PPM MAX. AFTER IR REFLOW PROCESS AS NOTE 3.
 - APPLIED TO WAVE SOLDERING PROCESS
 - NET WEIGHT: 4.5g.
- OBsolete PARTS: OBsolete CIS STREAMLINING PER D.RENAUD/D.SINISI

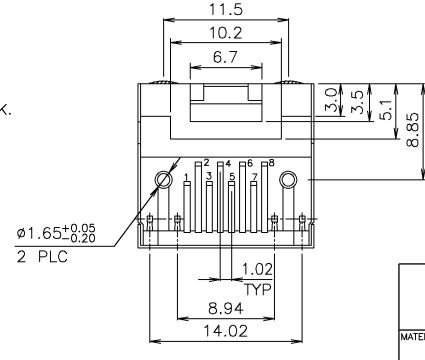

OBSOLETE	TRAY	YELLOW	GREEN	50µ"	1734509-8
				30µ"	1734509-7
				15µ"	1734509-6
		GREEN	YELLOW	6µ"	1734509-5
				50µ"	1734509-4
				30µ"	1734509-3
PACKAGE	POSITION 2	POSITION 1	MIN. GOLD THICKNESS	PART NUMBER	
	INDICATOR COLOR				

DIMENSION -	DWN	O. HU	TYCO	TYCO HOLDINGS (BERMUDA)
0 PLC ±0.5	CHK	03-OCT-2005	Electronics	VII LTD. TAIWAN BRANCH
1 PLC ±0.30		S. HOU		
2 PLC ±0.20		03-OCT-2005		
3 PLC ±0.10				
ANGLES ±3°				
MATERIAL	APVD	W.J. KE	MODULAR JACK RJ45 8P8C, WITH LED & SHIELD, DIP, REVERSE TYPE	
SEE NOTE	PRODUCT SPEC	108-57527		
FINISH	QUALIFICATION TEST REPORT	501-57603	LOC DW	DRAWING NO C-1734509
SEE NOTE	WEIGHT		SCALE	SHEET 1 OF 4

A1	REVISED PER ECO-10-000445	KK	AEG	JAN10
A	REVISED	ECR-05-002749	OH	03OCT 2005
O	FIRST RELEASED	FZ00-0275-04	OH	26NOV 2004
LTR	REVISION RECORD	ECN	DWN	CHK DATE

NUMBER
C-1734509

METRIC
3RD ANGLE PROJECTION

THIS INFORMATION IS CONFIDENTIAL AND IS DISCLOSED TO YOU ON THE CONDITION THAT NO FURTHER DISCLOSURE IS MADE BY YOU TO OTHER THAN AMP PERSONNEL WITHOUT THE WRITTEN PERMISSION OF AMP. DIMENSIONS IN MILLIMETERS. DO NOT SCALE PRINT.

PRINT DW
DW

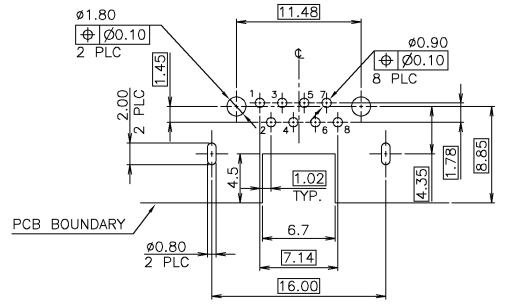
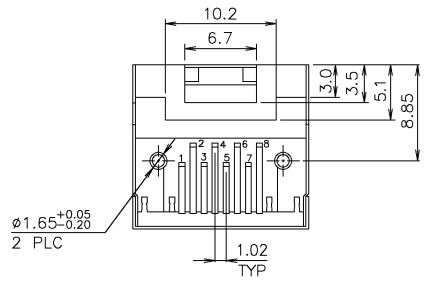
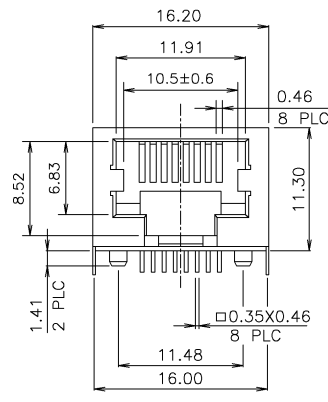
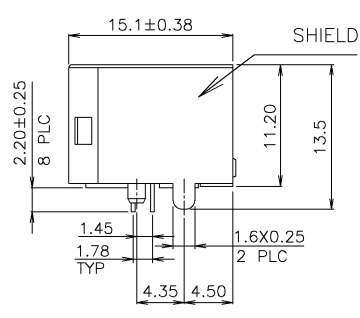
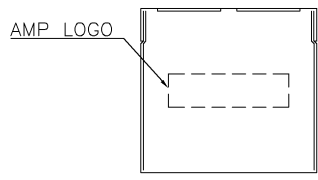

RECOMMENDED PCB LAYOUT (THICKNESS: 1.6MM)
(DIMENSION TOLERANCE: 1 PLC: ±0.1, 2 PLC: ±0.05)

NOTE:

- MATERIAL:
HOUSING: HIGH THERMOPLASTIC, UL94V-0, COLOR: BLACK.
CONTACT: PHOSPHOR BRONZE, THICKNESS: 0.35mm.
SHELL: BRASS, THICKNESS: 0.25mm.
- FINISH:
CONTACT: GOLD PLATED (SEE TABLE) IN CONTACT AREA,
GOLD FLASH ON SOLDER TAILS,
50u" MIN. NICKEL UNDER PLATED ALL OVER.
SHIELD: 20u" MIN NICKEL PLATED.
- APPLIED TO WAVE SOLDERING PROCESS
- NET WEIGHT: 4.5g.

⚠️ OBSOLETE PARTS: OBSOLETE CIS STREAMLINING PER D.RENAUD/D.SINISI

OBSOLETE	TAPE & REEL	50µ"	1-1734509-4
		30µ"	1-1734509-3
		15µ"	1-1734509-2
		6µ"	1-1734509-1
	PACKAGE	MIN. GOLD THICKNESS	PART NUMBER

"WITH OUT LED LIGHT"

DIMENSION :	DWN	O. HUI	tyco TYCO HOLDINGS (BERMUDA)	
0 PLC ±0.5	CHK	03-OCT-2005	VII LTD. TAIWAN BRANCH	
1 PLC ±0.30		S. HOU	NAME	
2 PLC ±0.20		03-OCT-2005	Electronics	
3 PLC ±0.10			APVD W.J. KE	
ANGLES ±3°			03-OCT-2005	
MATERIAL	PRODUCT SPEC	108-57527	MODULAR JACK RJ45 8P8C, WITH LED & SHIELD, DIP, REVERSE TYPE	
SEE SHEET 1.	QUALIFICATION TEST REPORT	501-57603	LOC	SIZE
FINISH	WEIGHT		DW	DRAWING NO
SEE SHEET 1.			A3	C-1734509
			SCALE	REV
			--	A1
				SHEET
				2 OF 4

SEE SHEET 1.	ECN	DWN	CHK	DATE
LTR	REVISION RECORD			

CUSTOMER DRAWING

NUMBER C-1734509
 METRIC
 3RD ANGLE PROJECTION

THIS INFORMATION IS CONFIDENTIAL AND IS RELEASED TO YOU ON A CONDITION THAT NO FURTHER DISCLOSURE IS MADE BY YOU TO OTHER THAN AMP PERSONNEL WITHOUT THE WRITTEN PERMISSION OF AMP. DO NOT SCALE PRINT.

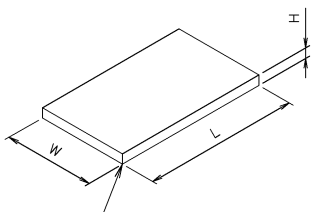
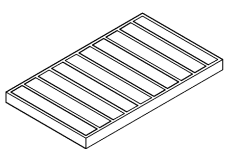
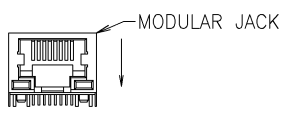
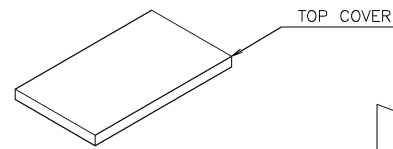

TRAY
 290mm(L)X170mm(W)X17mm(H)
 90 PCS/ TRAY
 TRAY MATERIAL: PET.

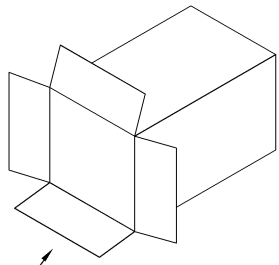

INNER CARTON
 300mm(L)X180mm(W)X180mm(H)
 10 TRAYS / INNER CARTON
 TOTAL: 900 PCS

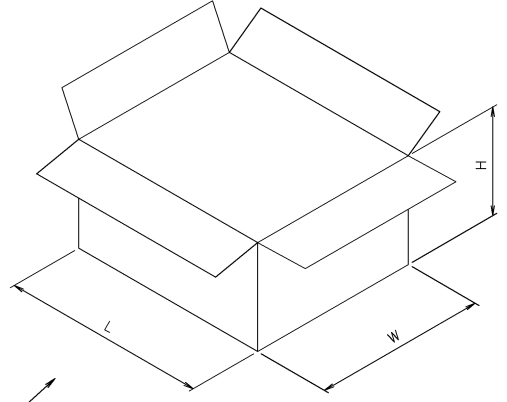
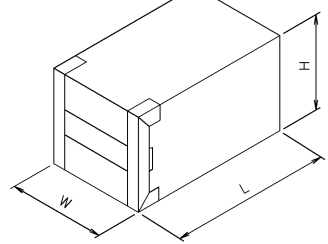

OUTER CARTON
 380mm(L)X320mm(W)X200mm(H)
 2 INNER CARTON / OUTER CARTON
 TOTAL: 1800 PCS
 GROSS WEIGHT: 9.5 Kg.

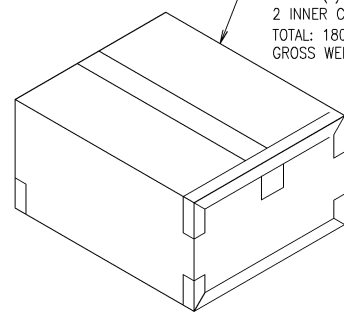

DIMENSION :		DWN	O. HU	tyco	TYCO HOLDINGS (BERMUDA)
0 PLC ±		CHK	03-OCT-2005	Electronics	VII LTD. TAIWAN BRANCH
1 PLC ++		S. HOU		NAME	
2 PLC +++		03-OCT-2005		MODULAR JACK RJ45 8P8C,	
3 PLC ++++		APVD		WITH LED & SHIELD, DIP,	
ANGLES #		W.J. KE		REVERSE TYPE	
MATERIAL		03-OCT-2005		LOC	
SEE SHEET 1.		PRODUCT SPEC		SIZE	DRAWING NO
FINISH		APPLICATION SPEC		DW	A3
SEE SHEET 1.		WEIGHT		SCALE	C-1734509
LTR		REVISION RECORD		ECN	REV
DWN		CHK		DATE	A1
SCALE		SHEET		3 OF 4	

SEE SHEET 1.	ECN	DWN	CHK	DATE
REVISION RECORD				

CUSTOMER DRAWING

8 7 6 5 4 3 2 1

NUMBER
C-1734509

METRIC
3RD ANGLE PROJECTION

THIS INFORMATION IS CONFIDENTIAL AND IS DISCLOSED TO YOU ON A CONDITION THAT NO FURTHER DISCLOSURE IS MADE BY YOU TO OTHER THAN TAMP PERSONNEL WITHOUT THE WRITTEN PERMISSION OF TAMP. THIS INFORMATION IS NOT TO BE PRINTED.

PRINT DW
DWT

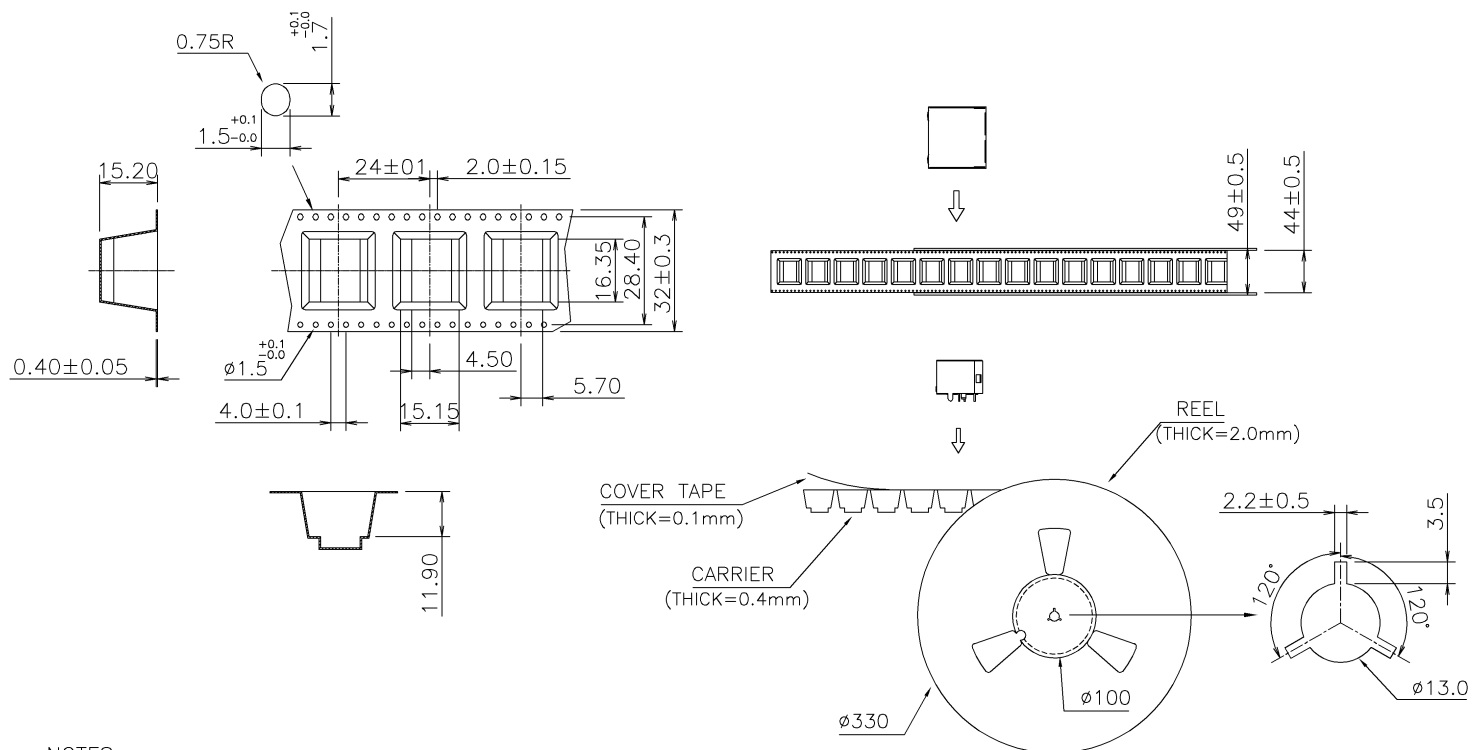

- NOTES:
- A. THE DIRECTION OF JACKS PUT INTO CARRIER.
 - B. 10 EMPTY CAVITIES FOR BOTH OF TOP AND BOTTOM OF THE CARRIER.
 - C. 180 PCS PRODUCTS BE PACKAGED ON REEL.
 - D. 1440 PCS PRODUCTS BE PACKAGED ONE CARTON.
CARTON SIZE: 345mm(L)X 345mm(W)X 315mm(H)
TOTAL CROSS WEIGHT: 10 Kg REF.

SEE SHEET 1.	ECN	DWN	CHK	DATE
LTR	REVISION RECORD			

DIMENSION : 0 PLC ± 1 PLC + 2 PLC ++ 3 PLC +++ ANGLES #	DWN O. HU 03-OCT-2005	CHK S. HOUJ 03-OCT-2005	tyco TYCO HOLDINGS (BERMUDA) Electronics VII LTD. TAIWAN BRANCH NAME	
MATERIAL SEE SHEET 1.	APVD W.J. KE 03-OCT-2005	PRODUCT SPEC	MODULAR JACK RJ45 8P8C, WITH LED & SHIELD, DIP, REVERSE TYPE	
FINISH SEE SHEET 1.	APPLICATION SPEC	WEIGHT	LOC DW	SIZE A3 DRAWING NO C-1734509 REV A1
			SCALE	SHEET 4 OF 4

CUSTOMER DRAWING